

# INSTRUCTION MANUAL

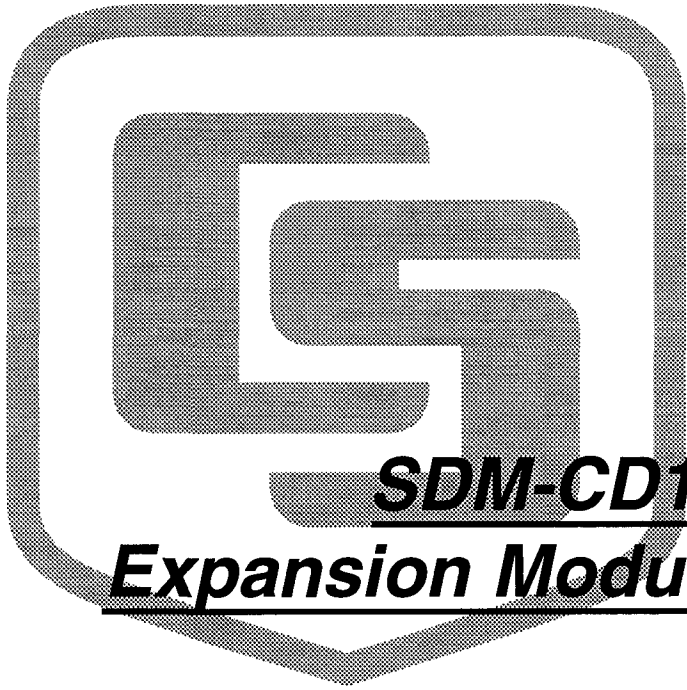

## **SDM-CD16 Control Port Expansion Module with Drivers**

Campbell Scientific, Inc.



**SDM-CD16 CONTROL PORT  
EXPANSION MODULE WITH DRIVERS  
INSTRUCTION MANUAL**

**REVISION: 1/92**

**COPYRIGHT (c) 1987, 1988, CAMPBELL SCIENTIFIC, INC.**



## WARRANTY AND ASSISTANCE

The **SDM-CD16 Control Port Expansion Module with Drivers** is warranted by CSI to be free from defects in materials and workmanship under normal use and service for twelve (12) months from date of shipment unless specified otherwise. Batteries have no warranty. CSI's obligation under this warranty is limited to repairing or replacing (at CSI's option) defective products. The customer shall assume all costs of removing, reinstalling, and shipping defective products to CSI. CSI will return such products by surface carrier prepaid. This warranty shall not apply to any CSI products which have been subjected to modification, misuse, neglect, accidents of nature, or shipping damage. This warranty is in lieu of all other warranties, expressed or implied, including warranties of merchantability or fitness for a particular purpose. CSI is not liable for special, indirect, incidental, or consequential damages.

Products may not be returned without prior authorization. To obtain a Returned Materials Authorization (RMA), contact CAMPBELL SCIENTIFIC, INC., phone (801) 753-2342. After an application engineer determines the nature of the problem, an RMA number will be issued. Please write this number clearly on the outside of the shipping container. Campbell Scientific's shipping address is:

Campbell Scientific, Inc.  
RMA # \_\_\_\_\_  
815 West 1800 North  
Logan, Utah 84321

CAMPBELL SCIENTIFIC, INC. does not accept collect calls.

Non-warranty products returned for repair should be accompanied by a purchase order to cover the repair.



## CAMPBELL SCIENTIFIC, INC.

P.O. Box 551  
Logan, UT 84321  
Phone (801) 753-2342  
TLX 453058  
FAX 801-752-3268

9525 41st Avenue  
Edmonton, Alberta T6E 5X7  
CANADA  
Phone (403) 461-5158  
TLX 037-2966 (EDM)  
FAX 403-450-2531

College Road/Sutton Bonington  
Loughborough, LE12 5RA  
ENGLAND  
Phone 01144509672516  
TLX 94016393 (CAMP G)  
FAX 01144509674928



# SDM-CD16

## TABLE OF CONTENTS

	PAGE
<b>WARRANTY</b>	
1. Function.....	1
2. Specifications .....	1
3. Power Considerations.....	2
4. Connections .....	3
5. Address Selection Jumpers.....	3
6. Datalogger Instruction.....	4
7. Theory of Operation .....	6
8. Program Example.....	6
Figure 1. SDM-CD16 Face Panel.....	1
Figure 2. Application Block Diagram.....	2
Figure 3. Use of External Clamping Diodes For Inductive Loads With Different Supply Voltages	4
Figure 4. Address Jumper Position .....	5

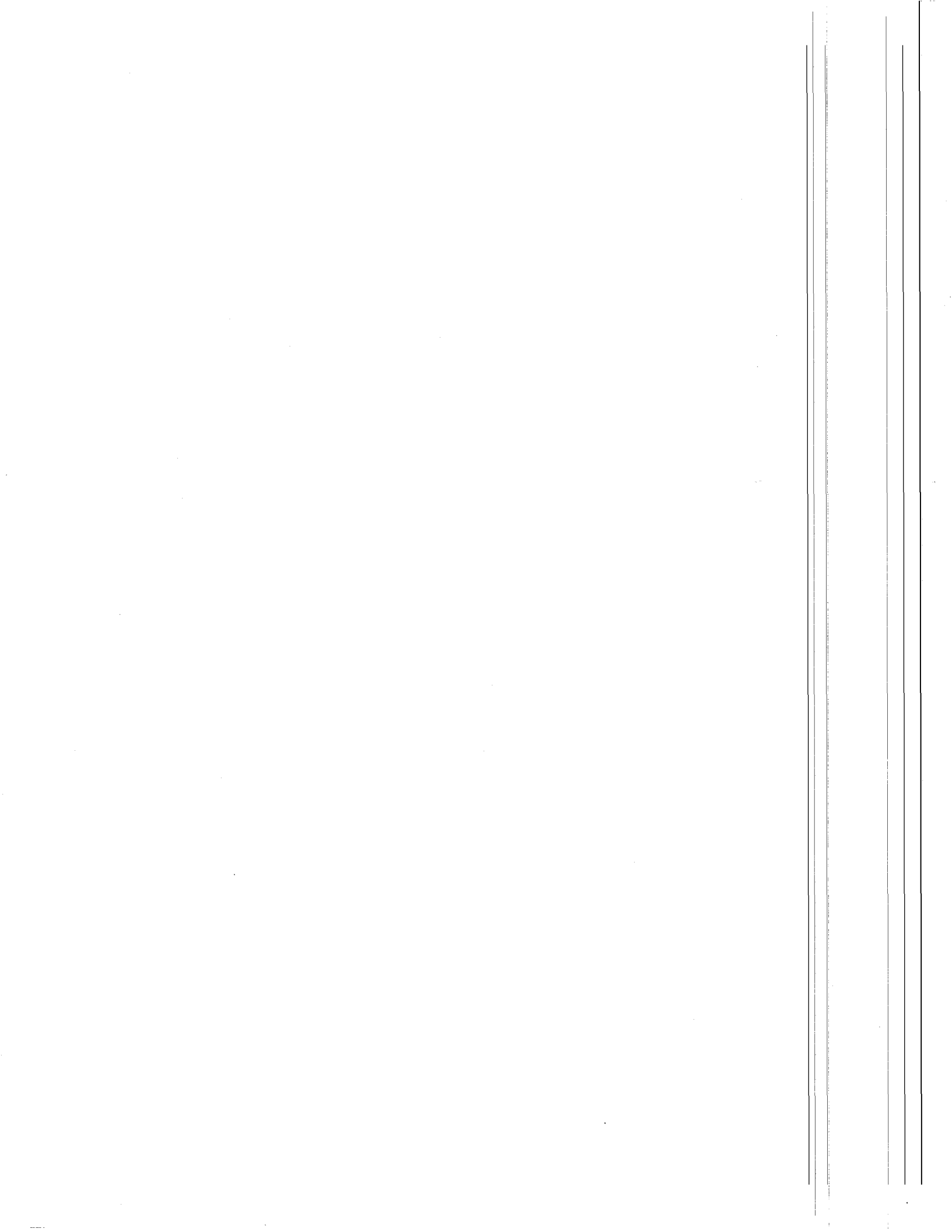



# SDM-CD16 CONTROL PORT EXPANSION MODULE WITH DRIVERS

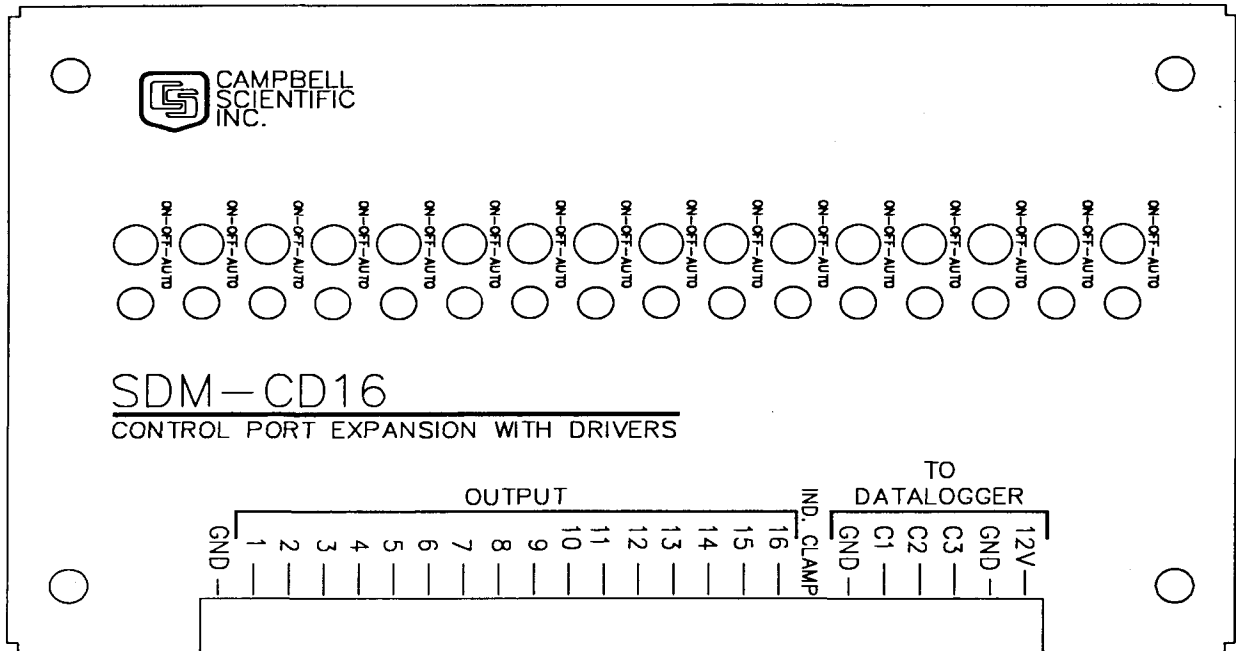

Figure 1. SDM-CD16 Face Panel

## 1. FUNCTION

The SDM-CD16 has 16 digital control ports with drivers and is compatible with CSI's CR10, 21X and CR7 dataloggers (refer to Figure 1). Each port can be controlled by a datalogger or controlled manually with an override toggle switch. Each port can be thought of as a switch to ground; closed when active, open when inactive. The primary function is to activate DC powered external relays, solenoids, or resistive loads under datalogger control.

The SDM-CD16 is a synchronously addressed datalogger peripheral. Datalogger control ports 1, 2, and 3 are used to address the SDM-CD16 then clock out the desired state of each of the 16 control ports. Up to 16 SDM-CD16s may be addressed, making it possible to control a maximum of 256 ports from the first three datalogger control ports.

I/O Instruction 104 is used by the 21X and CR10 to control the SDM-CD16. The CR7 uses Instruction 29. Ensure that the datalogger contains the appropriate Instruction prior to system deployment.

## 2. SPECIFICATIONS

Compatible dataloggers: CR10, 21X, CR7.

Operating voltage: 12 VDC nominal (9 to 18).

Current drain at 12 VDC: 6 mA quiescent; 11 mA per active LED (switch on or auto active); 1.4 mA per active port with switch off.

Maximum power per port from external relay, solenoid, resistive load: 40 VDC, 0.5 Amps.

Solid state FET protection: Thermal fuse increases in resistance at 1 Amp, allows no current flow after 2 Amps or 125 °C; clamping diode prevents inductive arcing.

Total length of connecting cable: 20 feet (CR10, 21X) 600 feet (CR7)

Toggle switch: ON/OFF manual override; AUTO for datalogger control.

Physical: 1.7"(H), 7"(L), 4.2"(W) 1 lb.

### 3. POWER CONSIDERATIONS

The SDM-CD16 power requirements are large compared to most CSI products. For most applications an external power supply, as shown in Figure 2, is recommended to power the SDM-CD16.

For some applications it may be convenient to use the datalogger supply to power the SDM-CD16. For long term applications the lead acid power supply available with CSI dataloggers should be used, allowing the batteries to be float charged. It is not recommended that the datalogger alkaline supply be used to power the SDM-CD16 for long term applications.

If the datalogger lead acid supply is used, the number of SDM-CD16's which can be powered is limited by the 300 mA current sourcing capability

of the wall charger. With a continuous 6 mA current drain per SDM-CD16 and 11 mA per active LED, a maximum of 26 LEDs may be powered by the datalogger, after which, more current is drawn than can be sourced by the wall charger. If this condition is maintained, it will ultimately lead to battery deep discharge, requiring new batteries.

If the 21X power supply is used to power the SDM-CD16, all low level analog measurements (thermocouples, pyranometers, thermopiles, etc.) must be made differentially. This is a result of slight ground potentials created along the 21X analog terminal strip when the 12V supply is used to power peripherals. This limitation reduces the number of available analog input channels and may mandate an external supply for the SDM-CD16.

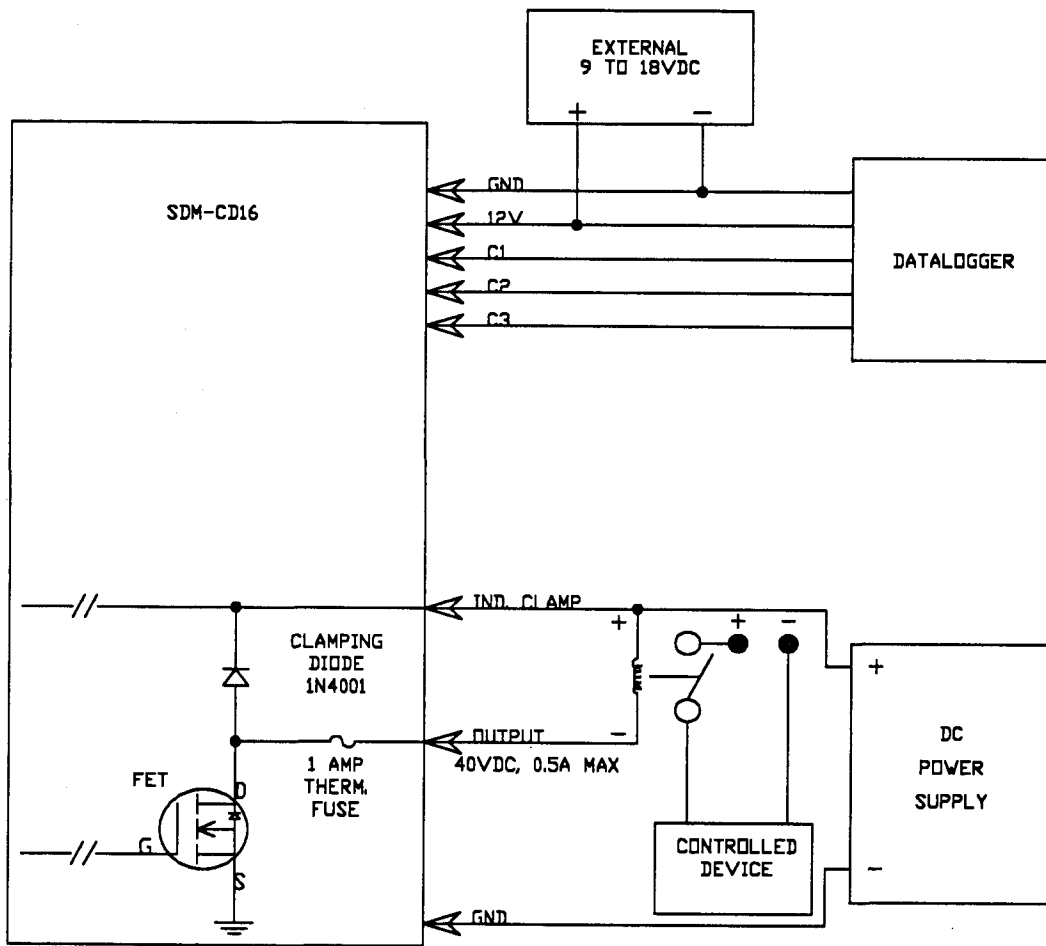

FIGURE 2. Application Block Diagram

Table 1. Datalogger to CD16 Connections

CONNECTION ORDER	SDM-CD16	DATALOGGER	FUNCTION
First	Gnd	Gnd	Common ground
Second	12V	12V on datalogger or external supply	Power
	C1	C1 (Control Port 1)	Data
	C2	C2 (Control Port 2)	Clock
	C3	C3 (Control Port 3)	Enable

4. CONNECTIONS

**CAUTION:** The order in which connections are made is critical. ALWAYS CONNECT GROUND FIRST, followed by 12V and then the Control Ports.

In the time between connecting power to the SDM-CD16 and the execution of the datalogger instruction controlling the SDM-CD16, the state of the 16 channels is indeterminate. To avoid activating a relay, solenoid, or resistive load during this time period, SDM-CD16 toggle switches should be in the "Off" position. Once all connections are made and the program is running, the toggle switches should be moved to the "Auto" position.

Under the "To Datalogger" portion of the SDM-CD16, make the connections to the datalogger shown in Table 1:

If relays or solenoids are to be activated, and they are all powered by the same external supply, connect the SDM-CD16 to the relay or solenoid power supply as follows:

SDM-CD16	RELAY OR SOLENOID SUPPLY
Ind. Clamp	Power
Gnd	Power Ground

The SDM-CD16 has a diode between each OUTPUT and the IND. CLAMP (inductive clamp, see Figures 1 and 2). This diode clamps the coil current when the FET opens. If various relays or solenoids are used requiring different supply voltage levels, DO NOT connect to the IND. CLAMP terminal. For this situation, diodes must

be provided external to the SDM-CD16, as shown in Figure 3.

For non-inductive loads, connection to the Ind. Clamp input is not necessary.

Multiple SDM-CD16's may be wired in parallel by connecting the datalogger side of one SDM-CD16 to the next. For CR10 and 21X dataloggers, the total cable length connecting SDM-CD16's to SDM-CD16's and the datalogger should not exceed 20 feet. Total cable lengths in excess of 20 feet will adversely influence communication performance. For CR7 dataloggers, the total cable length should not exceed 600 feet.

5. ADDRESS SELECTION JUMPERS

Each SDM-CD16 can have 1 of 16 addresses. Shipped from the factory, the address is set at 00. The address jumpers, G2 and J2, are shown in Figure 4. For both G2 and J2: Pin 1 jumpered to 8 is Position 0; pin 2 jumpered to 7 is Position 1; pin 3 jumpered to 6 is Position 2; pin 4 jumpered to 5 is Position 3. The following table shows jumper position and the corresponding address.

J2 POSITION	0	1	2	3
0	00	10	20	30
1	01	11	21	31
2	02	12	22	32
3	03	13	23	33

BASE 4 ADDRESS MATRIX  
(00, 01, 02 . . . 32, 33)

**SDM-CD16 Control Port Expansion Module with Drivers**

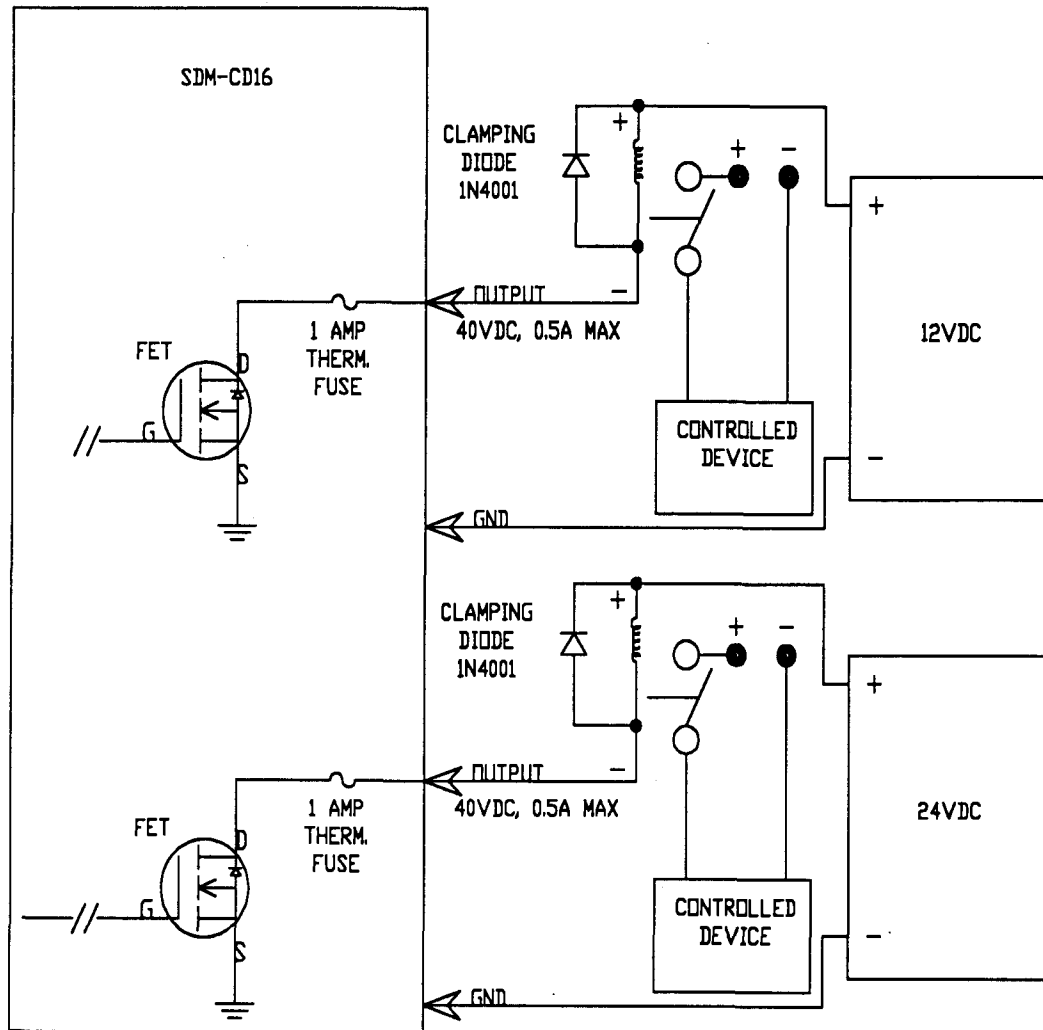

**FIGURE 3. Use of External Clamping Diodes For Inductive Loads With Different Supply Voltages**

**6. DATALOGGER INSTRUCTION - 104 (21X, CR10) 29 (CR7)**

Instruction 104 is used by the 21X and CR10 to control the SDM-CD16, and Instruction 29 is used by the CR7. The Instruction description is given below. SDM-CD16 outputs that are to be controlled by the datalogger must have the toggle switch in the AUTO position.

**Instruction 104 - SDM-CD16 use with CR10 and 21X**

<u>Parameter</u>	<u>Type</u>	<u>Description</u>
1	2	Reps (# of modules sequentially addressed)
2	2	Starting Address (base 4: 00..33)
3	4	Starting Input Location

**Execution Time = 2 ms per Rep for the CR10, 3.5 ms per Rep for the 21X**



**Instruction 29 - SDM-CD16 use with CR7**

<u>Parameter</u>	<u>Type</u>	<u>Description</u>
1	2	Reps (# of modules sequentially addressed)
2	2	Device (2 = SDM-CD16)
3	2	Starting Address (base 4: 00..33)
4	2	Card
5	4	Starting Input Location

**Execution Time = 150 to 190 ms per Rep**

The number of SDM-CD16s to be addressed is defined by the Reps (repetitions) parameter. Each Rep will sequentially address (00, 01, 02,...32, 33) SDM-CD16s starting with the address specified in parameter 2 (Instruction 29 parameter 3).

For each Rep, the 16 ports of the addressed SDM-CD16 are set according to 16 sequential Input Locations starting at the Input Location specified in parameter 3 (Instruction 29 parameter 5). Any non-zero value stored in an Input Location activates (connects to ground) the associated SDM-CD16 port. A value of zero (0) de-activates the port (open circuit). For example, assuming 2 Reps and a starting Input Location of 33, OUTPUT 1 through 16 of the first SDM-CD16 are set according to Input Locations 33 through 48, and OUTPUT 1 through 16 of the second SDM-CD16 are set according to Input Locations 49 through 64.

For Instruction 29, the Device (parameter 2) specifies what type of synchronously addressed peripheral is to be addressed. The Device code for an SDM-CD16 is 2.

For Instruction 29 only (CR7), the Card parameter 4 specifies which 725 Excitation Card is being used for the Control Port signals. The Reps parameter does not advance beyond the specified Card, requiring another Instruction 29 for each 725 Excitation Card used.

**7. THEORY OF OPERATION**

The SDM-CD16 is a synchronously addressed peripheral. C2 and C3, driven high by the datalogger, initiate a cycle. While holding C3 high, the datalogger drives C2 as a clock line and C1 as a serial data line. The datalogger shifts out a data bit on C1 (LSB first) on the falling edge of the C2 clock. The SDM-CD16 shifts in the C1 data bit on the rising edge of the C2 clock.

The first 8 bits clocked out represent the SDM-CD16 address. If the address matches the SDM-CD16's jumpered address, the SDM-CD16 is enabled. If enabled, the next 16 bits are shifted into the SDM-CD16, each bit controlling one port, the first of which controls OUTPUT1.

When the 16 control bits are clocked in, C2 is held high while C3 is pulsed low then high to latch the control bits. The datalogger then lowers both C3 and C2 to complete the cycle.

**8. PROGRAM EXAMPLE**

The example is written for the CR10 Measurement and Control Module. The program concepts presented are the same for the 21X and CR7 dataloggers with minor changes in the program code.

In this example, the SDM-CD16 is used to control the temperature between 23 and 28 °C in each of 5 greenhouses. In each green house the SDM-CD16 controls a heating unit, a refrigerating unit, and an air mixing fan according to the following conditions.

**SDM-CD16 Control Port Expansion Module with Drivers**

**Heating unit:** activate when temperature < 23.5 °C. Deactivate when temperature > 25.5 °C

**Cooling unit:** activate when temperature > 27.5 °C. Deactivate when temperature < 24.5 °C

**Mixing fan:** activate when ever the heating or cooling units are activated. Activate for 5 minutes out of every 15 minutes.

The program assumes the temperature measurements have been made, and the average temperature for each greenhouse is computed and residing in Input Locations 1 through 5.

Input Location assignments are as follows:

<u>Input Location</u>	<u>Input Location Label</u>	<u>Description</u>
1..5	Temp #1..#5	Avg temp, greenhouse 1..5
10..14	Heat #1..#5	Heater control, greenhouse 1..5 SDM-CD16 Port 1..5
15..19	Cool #1..#5	Cooler control, greenhouse 1..5 SDM-CD16 Port 6..10
20..24	Fan #1..#5	Fan control, greenhouse 1..5 SDM-CD16 Port 11..15

---

01: P 87	<i>Beginning of Loop</i>	<i>Master Loop, End</i>
01: 0	Delay	<i>Loop at Step 30</i>
02: 5	Loop Count	

**START HEATER CONTROL LOGIC**

02: P 89	<i>IF X &lt; = &gt; F</i>	<i>IF "HEATER ON" THRESHOLD IS EXCEEDED</i>
01: 1--	X Loc	
02: 4	<	
03: 23.5	F	
04: 30	Then Do	<i>THEN</i>
03: P 30	Z=F	<i>PUT A "1" INTO HEATER CONTROL LOCATION</i>
01: 1	F	
02: 0	Exponent of 10	
03: 10--	Z Loc :	
04: P 95	End	<i>END THEN DO/END</i>
05: P 89	<i>IF X &lt; = &gt; F</i>	<i>IF THE HEATER IS HEAT #1 ON (HEATER CONTROL LOCATION &lt; &gt; 0)</i>
01: 10--	X Loc	
02: 2	< >	
03: 0	F	
04: 30	Then Do	<i>THEN</i>
06: P 89	<i>If X &lt; = &gt; F</i>	<i>TEMP #1 CHECK UPPER THRESHOLD TO SEE IF HEATER SHOULD BE TURNED OFF</i>
01: 1--	X Loc	
02: 3	> =	
03: 25.5	F	
04: 30	Then Do	
07: P 30	Z=F	<i>IF HEATER SHOULD BE TURNED OFF, ENTER A "0" INTO HEATER CONTROL LOCATION</i>
01: 0	F	
02: 0	Exponent of 10	
03: 10--	Z Loc :	
08: P 95	End	<i>END THEN DO/END</i>





**START FAN CONTROL LOGIC BASED ON HEATER/COOLER**

```

22: P 89      If X<=>F                IF HEATER IS ON
01:  10--    X Loc
02:   2      <>
03:   0      F
04:  11      Set high Flag 1        SET FLAG 1

23: P 89      If X<=>F                IF COOLER IS ON
01:  15--    X Loc
02:   2      <>
03:   0      F
04:  11      Set high Flag 1        SET FLAG 1

24: P 91      If Flag/Port           IF FLAG 1 IS SET
01:  11      Do if flag 1 is high
02:  30      Then Do                THEN

25: P 30      Z=F                     PUT A '1' INTO FAN
01:   1      F                       CONTROL LOCATION
02:   0      Exponent of 10
03:  20--    Z Loc :

26: P 94      Else                     ELSE, IF FLAG 1 IS RESET

27: P 30      Z=F                     PUT A '0' INTO FAN
01:   0      F                       CONTROL LOCATION
02:   0      Exponent of 10
03:  20--    Z Loc :

28: P 95      End                       END THEN DO/ELSE/END

29: P 86      Do                       RESET FLAG 1
01:  21      Set low Flag 1

30: P 95      End                       END LOOPEND MASTER LOOP

END FAN CONTROL LOGIC BASED ON HEATER/COOLER

```

**START FAN CONTROL LOGIC BASED ON TIME**

```

31: P 92      If time is              IF 5 MINUTES REMAIN
01:  10      minutes into a          OUT OF 15 MINUTE
02:  15      minute interval        INTERVAL,
03:  12      Set high Flag 2        SET FLAG 2

32: P 91      If Flag/Port           IF FLAG 2 IS SET
01:  12      Do if flag 2 is high
02:  30      Then Do                THEN

33: P 87      Beginning of Loop      START FAN LOOP
01:   0      Delay
02:   5      Loop Count

```

**SDM-CD16 Control Port Expansion Module with Drivers**

34:	P	30	Z=F	<i>PUT A "1" INTO FAN</i>
01:		1	F	<i>CONTROL LOCATION</i>
02:		0	Exponent of 10	
03:		20--	Z Loc :	
35:	P	95	End	<i>END LOOPEND FAN LOOP</i>
36:	P	95	End	<i>END THEN DOEND THEN DO/END</i>
37:	P	92	If time is	
01:		0	minutes into a	<i>RESET FLAG 2 AT THE</i>
02:		15	minute interval	<i>END OF THE 15 MINUTE</i>
03:		22	Set low Flag 2	

END FAN CONTROL LOGIC BASED ON TIME

**INPUT LOCATIONS 10 THROUGH 24 ARE NOW LOADED WITH "1" OR "0" TO SET PORTS ON THE SDM-CD16.**

38:	P	104	SDM-CD16	<i>SEND INSTRUCTIONS TO THE</i>
01:		1	Reps	<i>SDM-CD16 WITH ADDRESS 00</i>
02:		00	Address	
03:		10	Loc	
39:	P		End Table 1	