

**012 WEATHER STATION
OPERATOR'S MANUAL**

REVISION: 9/91

COPYRIGHT (c) 1989, 1991 CAMPBELL SCIENTIFIC, INC.

WARRANTY AND ASSISTANCE

The **012 WEATHER STATION** is warranted by CAMPBELL SCIENTIFIC, INC. to be free from defects in materials and workmanship under normal use and service for twelve (12) months from date of shipment unless specified otherwise. Batteries have no warranty. CAMPBELL SCIENTIFIC, INC.'s obligation under this warranty is limited to repairing or replacing (at CAMPBELL SCIENTIFIC, INC.'s option) defective products. The customer shall assume all costs of removing, reinstalling, and shipping defective products to CAMPBELL SCIENTIFIC, INC. CAMPBELL SCIENTIFIC, INC. will return such products by surface carrier prepaid. This warranty shall not apply to any CAMPBELL SCIENTIFIC, INC. products which have been subjected to modification, misuse, neglect, accidents of nature, or shipping damage. This warranty is in lieu of all other warranties, expressed or implied, including warranties of merchantability or fitness for a particular purpose. CAMPBELL SCIENTIFIC, INC. is not liable for special, indirect, incidental, or consequential damages.

Products may not be returned without prior authorization. To obtain a Returned Materials Authorization (RMA), contact CAMPBELL SCIENTIFIC, INC., phone (435) 753-2342. After an applications engineer determines the nature of the problem, an RMA number will be issued. Please write this number clearly on the outside of the shipping container. CAMPBELL SCIENTIFIC's shipping address is:

CAMPBELL SCIENTIFIC, INC.

RMA# _____
815 West 1800 North
Logan, Utah 84321-1784

CAMPBELL SCIENTIFIC, INC. does not accept collect calls.

Non-warranty products returned for repair should be accompanied by a purchase order to cover the repair.



CAMPBELL SCIENTIFIC, INC.

815 W. 1800 N.
Logan, UT 84321-1784
USA
Phone (435) 753-2342
FAX (435) 750-9540
www.campbellsci.com

Campbell Scientific Canada Corp.
11564 -149th Street
Edmonton, Alberta T5M 1W7
CANADA
Phone (780) 454-2505
FAX (780) 454-2655

Campbell Scientific Ltd.
Campbell Park
80 Hathern Road
Shepshed, Loughborough
LE12 9GX, U.K.
Phone +44 (0) 1509 601141
FAX +44 (0) 1509 601091

SPECIAL OPERATING NOTES

1. Check the shipping list in the front of the manual and make sure that all the parts checked off the list are with the weather station. If any parts are missing please contact Campbell Scientific, Inc. 435-753-2342.
2. When connecting the battery avoid shorting the battery to the weather station base (Section 2.5.1).
3. Damage to the electronics will occur if moisture builds up inside the weather station. A moisture detection sensor is used to detect excessive humidity levels. This reading must be monitored and corrective action taken if moisture is detected (Section 4).
4. The hex bolts sealing the squeeze plates at each end of the canister must be tightened every spring and fall to maintain seal integrity (Section 4).

012 WEATHER STATION TABLE OF CONTENTS

	PAGE
SECTION 1. WEATHER STATION DESCRIPTION	
1.1 Standard Sensors	1-1
1.2 Data Retrieval Options	1-1
1.3 Power Supply Options	1-1
SECTION 2. WEATHER STATION INSTALLATION	
2.1 Site Selection	2-1
2.2 Tools and Supplies	2-1
2.3 Foundation Construction	2-2
2.4 Weather Station Assembly	2-4
2.5 Power Supply Installation	2-6
2.6 Data Retrieval Option Installation	2-9
2.7 Sensor Verification Using the CR10KD Keyboard Display	2-14
2.8 Setting the Clock with the CR10KD Keyboard Display	2-14
2.9 Setting Flag 1 to Enable Soil Temperature Measurements	2-16
SECTION 3. PROGRAMMING	
3.1 Programming Sensor Measurements	3-1
3.2 PC208 Datalogger Support Software	3-5
SECTION 4. MAINTENANCE	
4.1 Moisture in Canister	4-1
4.2 Rain Gage	4-1
4.3 Solar Radiation	4-1
4.4 Wind Speed and Direction	4-1
4.5 Temperature and Relative Humidity Probe	4-2
4.6 Battery Voltage	4-2
SECTION 5. TROUBLESHOOTING	
5.1 Sensor Troubleshooting	5-1
5.2 Datalogger Troubleshooting	5-1
APPENDICES	
Apdx A. Program Listing	A-1
Apdx B. Sensor Specifications and Schematics	B-1
TABLES	
2.2-1 Tool Requirements	2-1
2.2-2 Materials Requirements for Constructing Foundation	2-1
2.6 Rad Modem Connections	2-10
2.7-1 Sensor Verification	2-16
2.8 Sequence of Time Parameters in *5 Mode	2-16
3.0 012 Standard Program Outputs	3-1
3.1 Parameters for Sensor Measurement Instruction	3-2

012 TABLE OF CONTENTS

FIGURES

2.1	Effect of Structure on Wind Flow	2-1
2.3-1	012 Foundation Construction	2-2
2.3-2	012 Weather Station with Solar Panel	2-3
2.3-3	Template and Anchor Bolt Assembly	2-3
2.4-1	012 Weather Station Assembly	2-4
2.4-2	Wind Set Alignment	2-5
2.5-1	Battery/Solar Panel Connections	2-7
2.5-2	Battery/AC Charging Connections	2-8
2.6-1	RAD Modem Connections	2-10
2.6-2	Phone Modem Connections	2-11
2.6-3	012 Weather Station with Radio Antenna	2-12
2.6-4	012 Weather Station with Storage Module	2-13
2.8	Day of Year Calendar	2-15
5.2	CR10 Serial I/O Connector	5-2
B.1	Sensor Channel Assignments and Connections	B-1
B.2	Sensor Wind Direction	B-2
B.3	Sensor Rain Gage	B-3
B.4	Sensor Pyranometer	B-4
B.5	Sensor Temperature and RH	B-5
B.6	Sensor Air Temperature	B-6
B.7	Sensor Soil Temperature	B-7
B.8	Sensor Wind Speed	B-8

SECTION 1. WEATHER STATION DESCRIPTION

The 012 Weather Station is designed to reduce the cost and logistics of routine climatological monitoring. Installation is simplified through a modular design and prewired sensors. This manual covers installation, sensor options, power supply options, programming, maintenance, and trouble shooting.

1.1 STANDARD SENSORS

Sensors with preassigned channels include:

- wind speed
- wind direction
- temperature
- relative humidity
- solar radiation
- rainfall
- soil temperature
- moisture detection

Section 3 explains the channel assignments and how to program the weather station.

1.2 DATA RETRIEVAL OPTIONS

Telecommunication options include phone, short haul, and radio. Different options require different wiring connections in the base of the weather station. Section 2 covers various modem options.

When telecommunications are not required, storage modules (SM192, SM716) may be used for on-site data retrieval.

1.3 POWER SUPPLY OPTIONS

The base of the weather station is designed to fit a user supplied 12 VDC deep cycle marine battery. Power cables supplied with the station fit 3/8" diameter battery posts. The battery may be periodically replaced with a freshly charged one, or it may be charged in place with either the PS12 charging regulator and 110 VAC to 16 VAC transformer, or the MSX10R solar panel. CSI offers a 7 Amp-hour rechargeable battery which should be continuously charged due to its small capacity.

SECTION 2. WEATHER STATION INSTALLATION

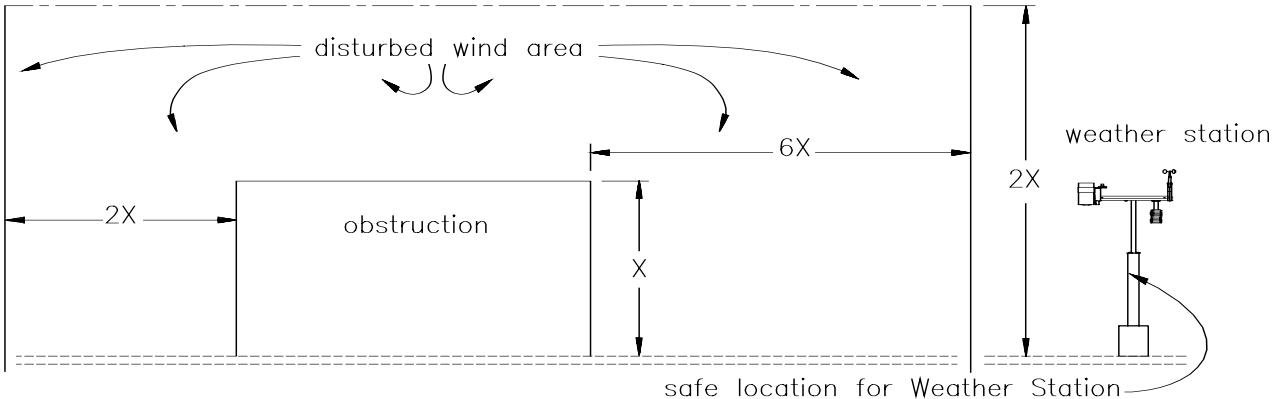

FIGURE 2.1. Effect of Structure on Wind Flow

2.1 SITE SELECTION

The site, including its climate and topography, should represent the general area being measured. Also avoid man-made or natural obstructions such as buildings, asphalt parking lots, and trees. General sensor placement guidelines are:

WIND SENSORS

Trees, buildings, or other structures can greatly influence wind speed and direction observations. As a rule of thumb, a structure will disturb the air flow an upwind distance of about twice the height of the structure; a downwind distance of about six times the height of the structure and a vertical distance of up to twice the height of the structure. (Figure 2.1).

TEMPERATURE AND RELATIVE HUMIDITY PROBE

The radiation shield provides protection from direct sunlight and rain. The shield does not protect against irrigation water which may be sprayed up into the plates. If the RH chip goes through wetting and drying cycles, the active sensing material separates from the substrate, damaging the sensor.

RAIN GAGE

Do not place the rain gage where it may catch irrigation water. When possible, there should be no obstructions in a 45° line rising off the lip of the gage.

SOLAR RADIATION

The pyranometer should be located so it is not shadowed by surrounding objects.

TABLE 2.2-1. Tool Requirements

• sledgehammer	• compass
• open end wrench 3/4"	• rag
• trowel (for cement)	• shovel
• tape measure	• flat metal file
• dozen 16 penny nails	• wheelbarrow
• wire strippers	• level
• screw driver, regular head	• hammer
• screw driver, phillips head	• wood saw
• screw driver, regular head thin blade	

2.2 TOOLS AND SUPPLIES

An itemized list of weather station components included in the shipment is found in the front of the manual. Tables 2.2-1 and 2.2-2 list the tools and supplies, respectively, required to install the weather station.

TABLE 2.2-2. Materials Requirements for Constructing Foundation

5	80 lb. sacks of sakrete
1	8' x 2" x 4" lumber
*	11" x 11" metal template
*	4 1/2" x 12" stainless steel anchor bolts
*	1" conduit elbow
	1 1/4" diameter x 3 1/2' long pipe (solar panel systems only)

*CSI supplied

SECTION 2. WEATHER STATION INSTALLATION

2.3 FOUNDATION CONSTRUCTION

The 012 Weather Station mounts on a cement foundation as shown in Figures 2.3-1 and 2.3-2. CSI provides a (1) metal template for locating the anchor bolts and conduit in the base, (2) four anchor bolts with two nuts each for leveling the station, and (3) a conduit for communication wire entry/exit at the base.

Step 1 - Dig an 18" square hole that is 12-13" deep. These estimates are for heavy soils only; light, shifting, or sandy soils require a deeper base (and more cement). Excavate a slot for the conduit elbow at about 9" below the surface on the side where the communication cables will enter. The slot should be oversized, making it easier to install the conduit (Step 3).

Step 2 - Construct a wood form for the above ground portion of the foundation. If the surface area of the hole is 18", cut two 18" and two 21.5" boards from the 8' 2x4. Nail the boards together to make an 18" (inside dimension) square form. Center the form over the hole.

Step 3 - Three cubic feet of cement are required to fill a 18" x 18" x 16" deep hole. This amounts to approximately five (5) eighty pound

(80 lb.) sacks of sakrete. Mix the cement. Stuff a rag into one end of the conduit elbow to prevent cement from clogging the conduit. While holding the conduit in place pour the cement. Examine the template to judge where to position the top of conduit. About 1.5 inches of conduit should be exposed above the cement surface.

Step 4 - While the cement is setting, assemble the template and anchor bolts as shown in Figure 2.3-3. Set the anchor bolts and template in the cement so the conduit is coming through the conduit hole in the template. The threaded end of the anchor bolts should extend a minimum of 1.75" above the top of the concrete. This will allow the template to rest on the lower set of nuts about 1" above the surface of the concrete (Figure 2.3-1). Adjustment of the lower set of nuts will allow you to level the template and later the 012 weather station. Do not remove the template. It is used as the bottom for the pedestal base when the weather station is assembled.

Step 5 - Weather stations using a solar panel for charging the battery need to insert a user supplied 1 1/4" pipe into the cement pad (Figure 2.3-2).

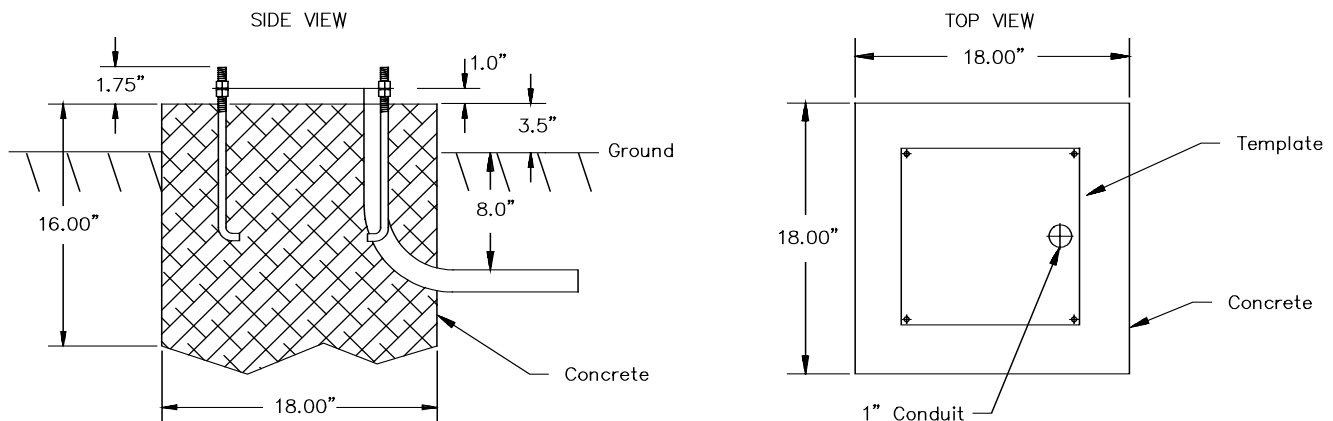

NOTES

1/2"x12" stainless steel anchor bolts extend a minimum of 1-3/4" above concrete. Footing is 18"x18"x16" deep (five 80# sacks of SAKRETE) for heavy soils. Footing depth should be increased for light, sandy or shifting soils.

FIGURE 2.3-1. 012 Foundation Construction

SECTION 2. WEATHER STATION INSTALLATION

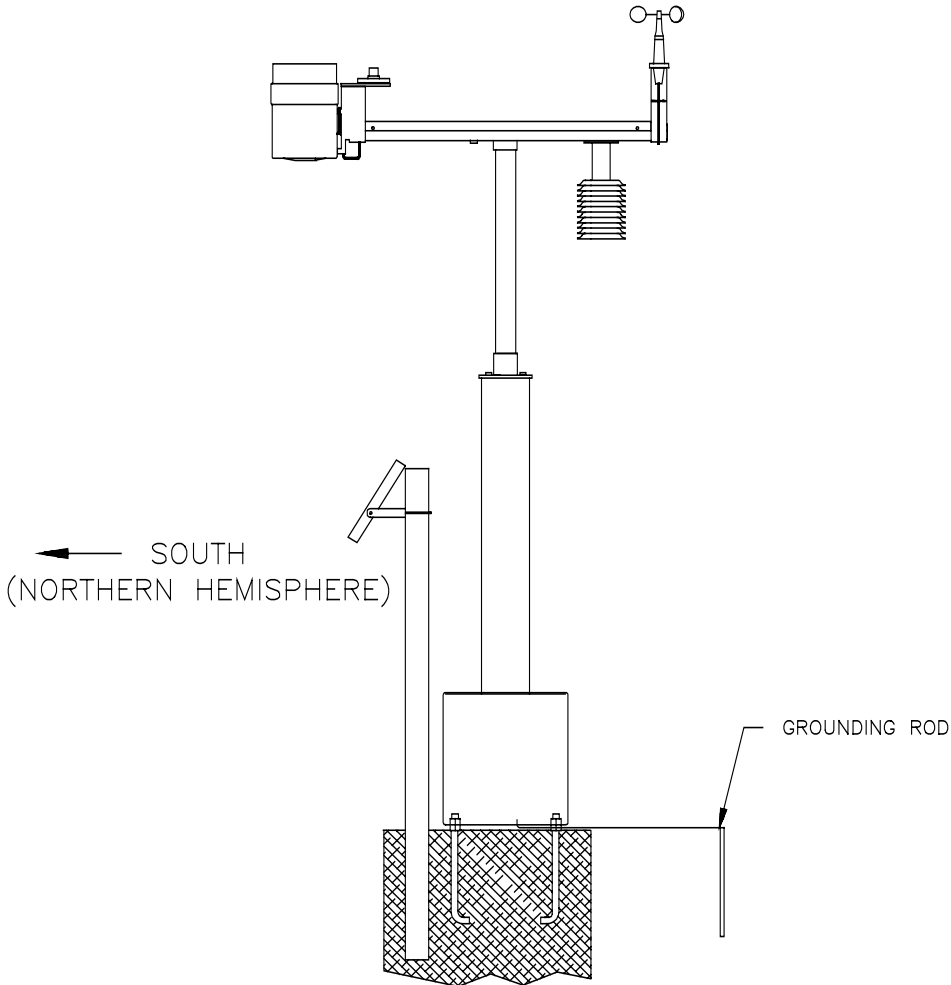

FIGURE 2.3-2. 012 Weather Station with Solar Panel

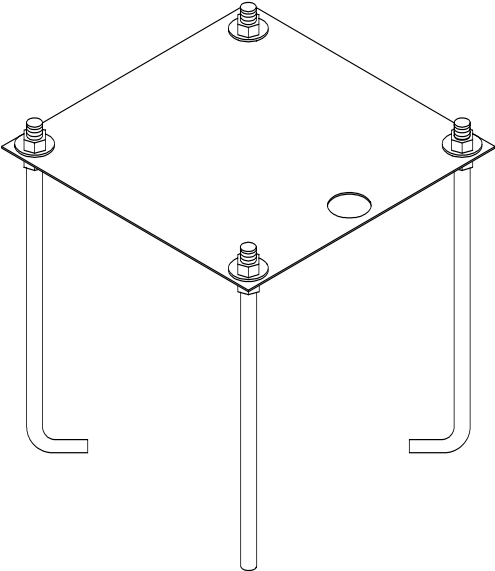

FIGURE 2.3-3. Template and Anchor Bolt Assembly

SECTION 2. WEATHER STATION INSTALLATION

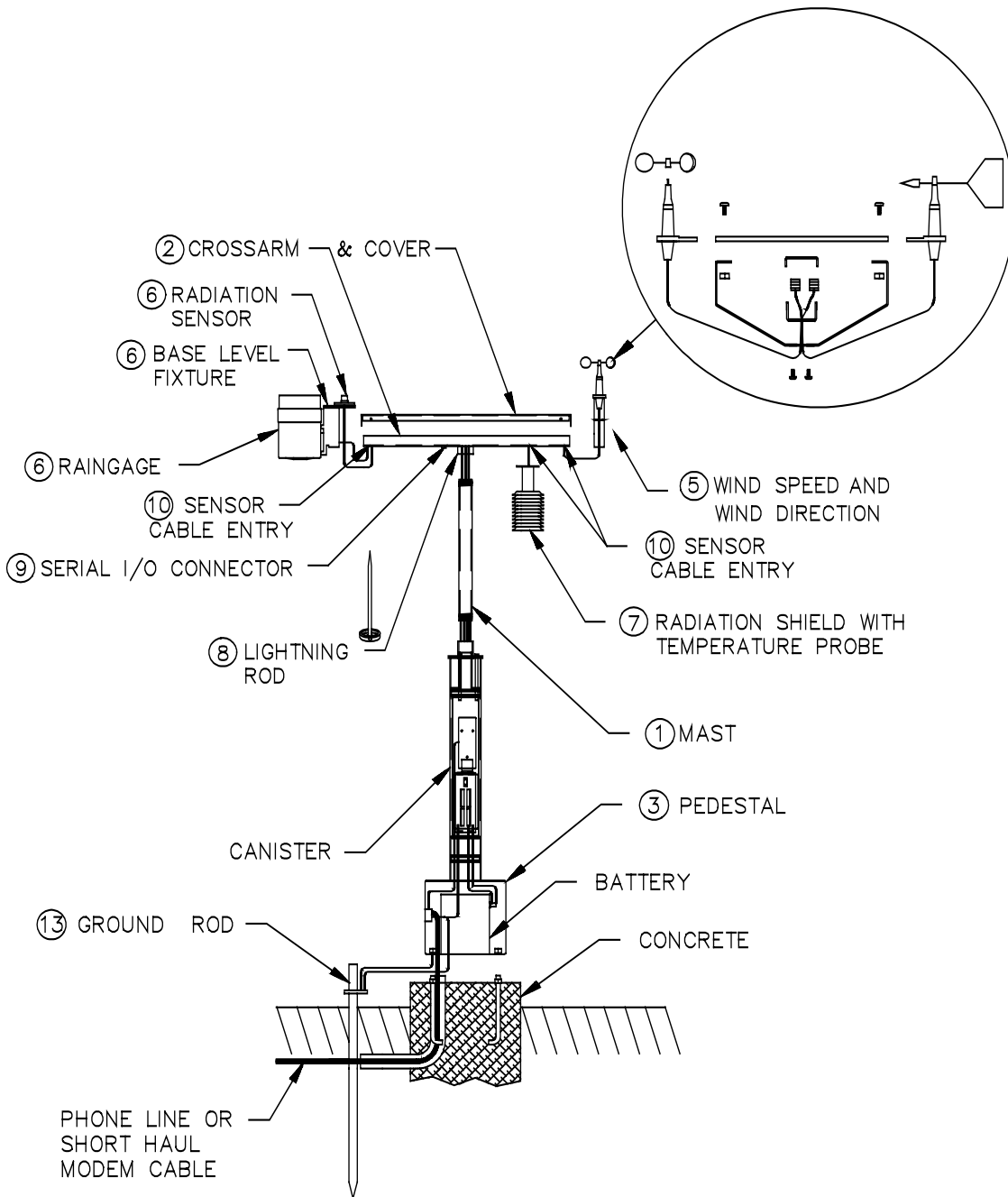

FIGURE 2.4-1. 012 Weather Station Assembly

2.4 WEATHER STATION ASSEMBLY

The following instructions describe the installation of the 012 weather station. All steps **except** those marked with an asterisk (*) are shown in Figure 2.4-1.

Before assembling the threaded ends of the mast, apply the teflon pipe dope provided with the weather station to prevent the aluminum from galling.

Step 1 — Thread the cables from the canister through the mast and hand tighten the mast to the canister. Do not twist the cables.

Step 2 — Remove the crossarm cover. Thread the cables through the center hole of the crossarm and screw the crossarm to the mast.

SECTION 2. WEATHER STATION INSTALLATION

CAUTION: Over-tightening the mast will cause excessive torque.

Step 3 — Mount the weather station on the cement pad aligning the conduit with the conduit notch in the bottom of the pedestal. Vertically plumb the weather station by adjusting the upper and lower nuts that secure the pedestal base to the anchor bolts.

***Step 4** — (Figure 2.4-2) Tighten the crossarm and mast as much as possible while aligning the crossarm north-south. The crossarm end, with the 1 5/8" hole on the underside, must be pointed north. Use of a compass is recommended as the crossarm orientation affects the accuracy of the wind direction measurement.

Step 5 — Mount the wind sensors on the north end of the crossarm using the brackets provided. The windset crossarm should be oriented east-west, with the wind direction sensor oriented to the east (Figure 2.4-2).

For stations which measure wind speed only, the wind speed sensor may be mounted on either end of the windset crossarm. A small square metal piece is provided to fill in the area left vacant for the wind direction sensor.

Step 6 — Mount the solar radiation and rain gage sensors on the south end of the crossarm.

NOTE: Insert the sensor cables through the grommets slot before attaching sensors to the crossarm.

Level the radiation sensor using the 3 adjustment screws and the fixtures bubble level.

NOTE: Accurate radiation measurements require accurate leveling.

Remove the top of the rain gage and make sure that the magnet is not holding the bucket at a dead center position. Manually tip the bucket, checking that it tips freely to both sides. Replace and level the the lid.

Step 7 — Mount the radiation shield into the 1 5/8" diameter hole on the underside of the crossarm. Put the Temperature and Relative Humidity sensor into the radiation shield. Make sure that the temperature and RH sensor is properly seated into the radiation shield.

NOTE: For weather stations with a temperature sensor only, the temperature sensor is mounted in the radiation shield.

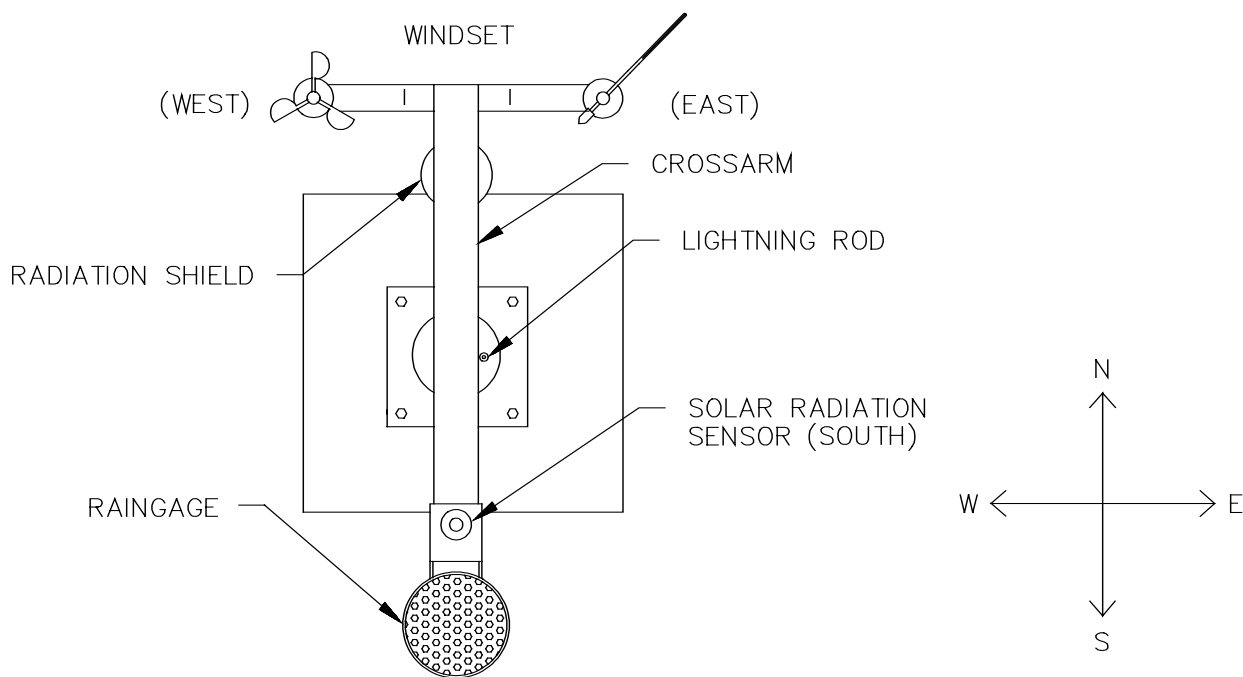

FIGURE 2.4-2. Wind Set Alignment

SECTION 2. WEATHER STATION INSTALLATION

Step 8 — Attach the lightning rod to the 1 1/4" sleeve on the underneath side of the crossarm.

***Step 9** — The serial (I/O) cable is mounted on the underside of the crossarm, near the mast. Remove the screws, insert the 9 pin D shaped connector, and then replace the screws.

NOTE: The cover lid is held in place by a long bolt. Make sure that the cover plate is in place before tightening the screws.

Step 10 — Route the windset cables through the bottom of the crossarm. Make sure the cables pass through the grommets slot.

***Step 11** — Observe the labeling on the sensor leads and connect the sensor cables to the appropriate canister cables. Arrange the connectors so they don't interfere with the crossarm cover. Tie down all sensor leads with the nylon ties provided in the ends of the crossarm. Replace the crossarm cover using the six screws.

***Step 12** — Double check the weather station to make sure that the solar radiation and rain gage sensors are level. Also, check to see that the wind direction sensor is mounted on the east side of the crossarm.

Step 13 — Proper grounding of the station is required to minimize damage from transients caused by lightning strikes or other voltage surges. Drive the copper plated ground rod into the earth adjacent to the weather station and attach the ground rod clamp. A 12 AWG green grounding wire is connected to a ground lug on the base. Connect the free end of the green wire to the ground rod clamp. This important step grounds the communications modem, the weather station, and the CR10 datalogger.

***Step 14** — The soil temperature probe is an optional sensor. Connections are made in the base for ease of installation into the soil.

2.5 POWER SUPPLY INSTALLATION

2.5.1 BATTERY INSTALLATION

NOTE: The 012 Weather Station base is at power ground. When installing the battery on the template inside the base, take care not to short the positive post of the battery to the base.

The battery may be continuously charged or periodically exchanged with a fresh one.

Following the procedure below, batteries may be replaced without losing power to the station. To install a battery, locate the terminal block inside the pedestal base where power supply connections are made (Figures 2.5-1 and 2.5-2). Connect the battery to the terminal labeled "Batt 12V". The power Sonic battery supplied by CSI is prewired with red lead positive and black lead negative. The Power Sonic should be continuously changed due to its smaller capacity, 6Ahr.

Connect a user supplied battery with one of the two power cables provided. Connect the cable to the "BATT 12V" red positive, black negative terminal block first then connect to the battery. Do not connect a battery to the AUX BATT 12V Terminal when using the PS12 charging regulator as explained below.

Battery Replacement — The battery should be replaced when discharged below 11 volts (Sections 2.7, 4.6). The second set of battery cables are provided for exchanging batteries without interrupting power to the CR10 Datalogger. Leave the old battery connected until the new battery is connected. Connect the cable to the "AUX BATT 12V" terminals first, then the circular lugs of the battery. Disconnect and remove the old battery. Store the cable until needed for the next battery change. **Never leave a battery cable connected to the power strip with the circular lugs dangling.**

WARNING: If the 12V power is disconnected from the weather station the data in the datalogger is lost.

2.5.2 CHARGING OPTIONS

CSI offers the PS12 12V Charger with 110 VAC to 16 VAC transformer or the MSX10R Solar Panel for continuously charging the battery power supply. The charging source must be connected to the terminals labeled "INPUT EXTERNAL CHARGING SOURCE". If ordered with the weather station, the PS12 is pre-mounted in the base. The MSX10R Solar Panel is used when AC power is not available.

NOTE: The "EXTERNAL CHARGING SOURCE" connects only to the "BATT 12V" terminals. The "AUX BATT 12V" terminals are not included in the charging circuit.

SECTION 2. WEATHER STATION INSTALLATION

PS12

For safety reasons, DO NOT mount the 110 VAC supply directly to the weather station. Mount the transformer external to the stations and run 16 VAC to the station (Figure 2.5-2). The maximum distance for the 16 VAC using an 18 awg cable is 2000 ft. The electrical connections should be done in accordance with the National, State, and Local electrical codes.

Solar Panel

The solar panel is mounted (Figure 2.3-2) on the south side of the weather station (northern hemisphere only) and connects to the terminals labeled "INPUT EXTERNAL CHARGING SOURCE" (Figure 2.5-1).

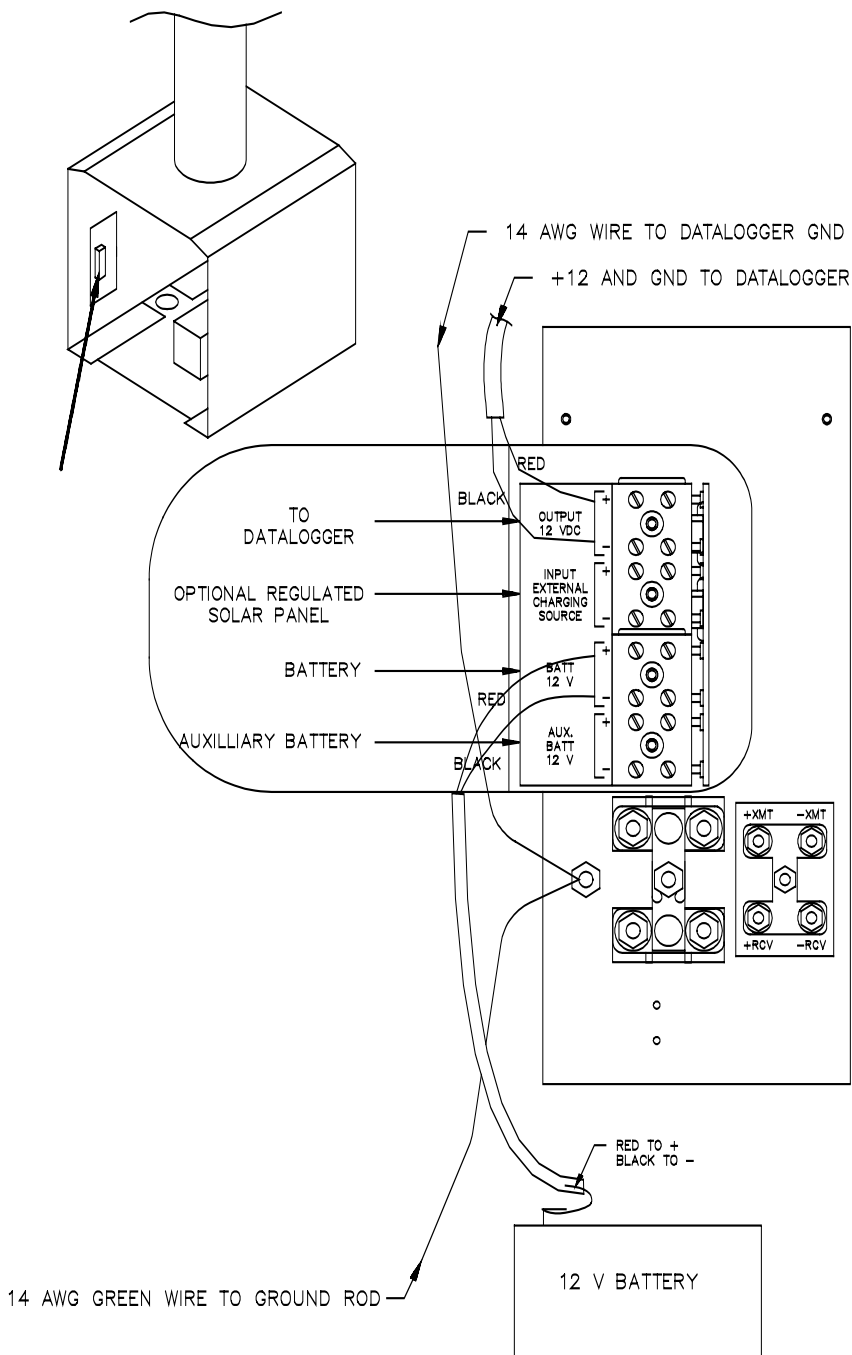

FIGURE 2.5-1. Battery/Solar Panel Connections

SECTION 2. WEATHER STATION INSTALLATION

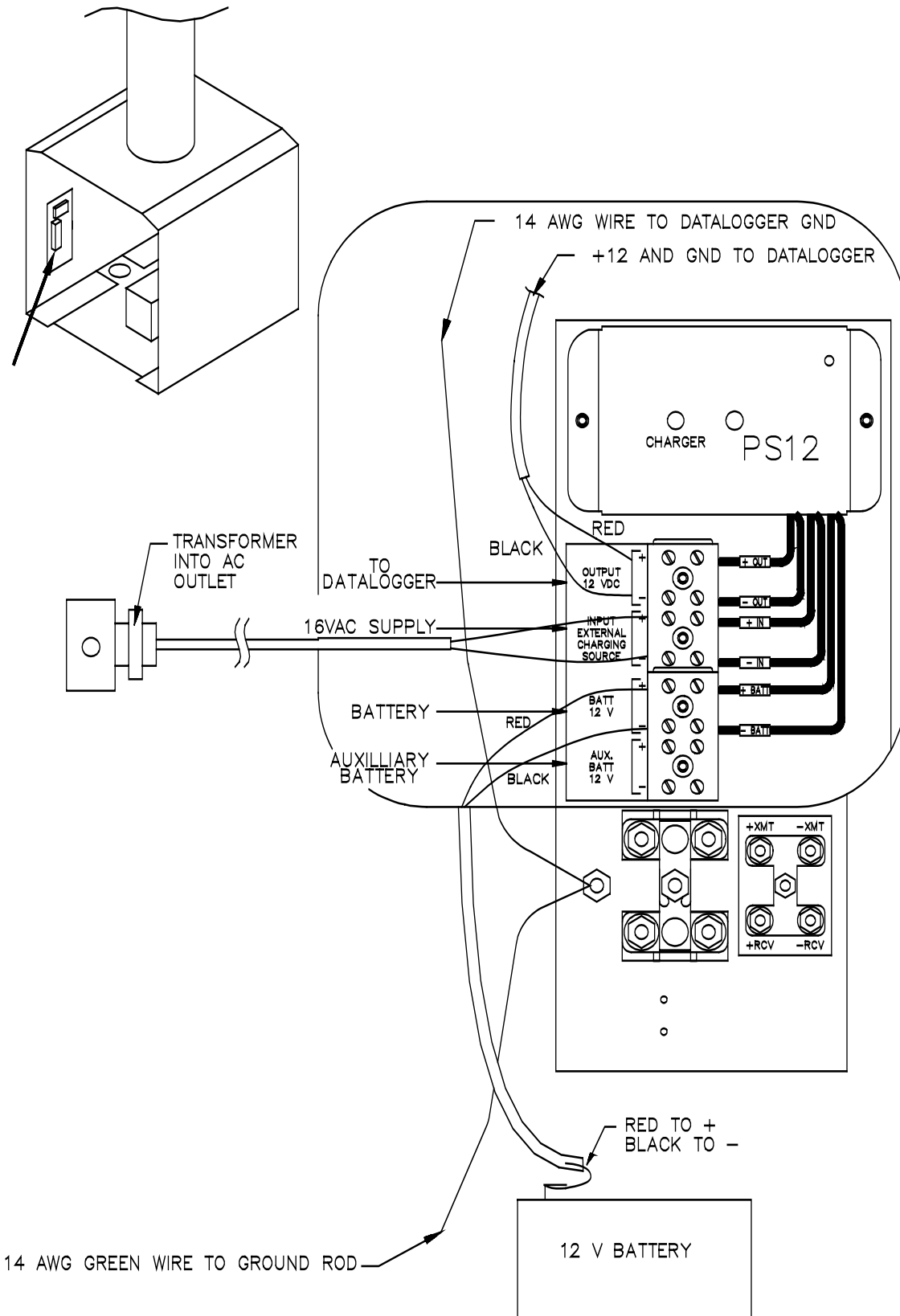

FIGURE 2.5-2. Battery/AC Charging Connections

SECTION 2. WEATHER STATION INSTALLATION

2.6 DATA RETRIEVAL OPTION INSTALLATION

The four options available for data collection are the Rad Modem, DC112 Phone Modem, RF95 Radio Frequency modem, and storage modules. Any modem ordered with the station is pre-mounted in the canister. Refer to the specific manuals of each device for technical information on the modems and storage modules.

2.6.1 RAD MODEMS

Figure 2.6-1 shows the RAD modem terminal block located inside the pedestal base. The communication cable is connected between the modem at the PC and the weather station according to the labels shown in Table 2.6. The communications cable connecting the station to the computer must be two twisted pairs (4 conductors) and suitable for burial. Examples are *Anixter part number F-02P22BPN (Rodent Proof) or *Belden part number 1048A.

TABLE 2.6. Rad Modem Connections

<u>SRM-6A at PC</u>	<u>Base of Weather Station</u>
+XMT	+XMT
-XMT	-XMT
+RCV	+RCV
-RCV	-RCV
*Anixter 4711 601 FRD Skokie, IL 60076 708-677-2600	*Belden P.O. Box 1980 Richmond, IN 47375 1-800-BELDEN1

2.6.2 DC112 PHONE MODEM

Figure 2.6-2 shows the phone modem terminal block located inside the pedestal base. A copper shielded, burial phone cable should enter the weather station pedestal via the conduit. Strip 1 7/8 inches of the insulation off the cable without cutting the copper

shield. Strip the shield 1 1/2", insert the cable into the ground lug mounted on the center terminal, and tighten it onto the copper shield.

CAUTION: Do not over tighten ground lug or damage to the phone line will occur.

Connect the RING signal (orange or blue wires) to the terminal labeled RING and the TIP signal (white/orange or white/blue wires) to the terminal labeled TIP.

2.6.3 RF MODEM

Mount the antenna to the mast of the weather station as shown in Figure 2.6-3. Fish the connecting COAX cable through the grommated hole in the bottom of the cross arm adjacent at the mast. Connect the cable to the antenna. Take care not to kink the COAX cable or damage will occur.

The RF95 Modem must be removed from the canister to set the station ID number if the switches have not been preset. Directions for setting the ID switches are described in the Radiotelemetry Network Applications Manual.

2.6.4 STORAGE MODULE SM192/SM716

The CR10 is programmed to automatically transfer data when it detects that a storage module is connected. The storage module is brought to the site and connected to the CR10 as shown in Figure 2.6-4. Data transfer begins within 5 seconds after making connections, and ends a maximum of 55 seconds later. If an SC90 Line Monitor is used, an LED turns on and off when data transfer starts and stops, respectively. Disconnect the storage module and proceed to the office for data playback. **Never leave the storage module connected to the weather station.**

SECTION 2. WEATHER STATION INSTALLATION

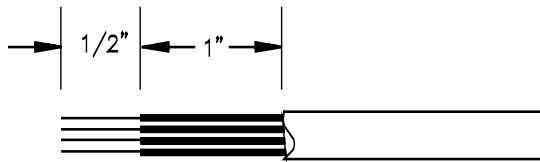
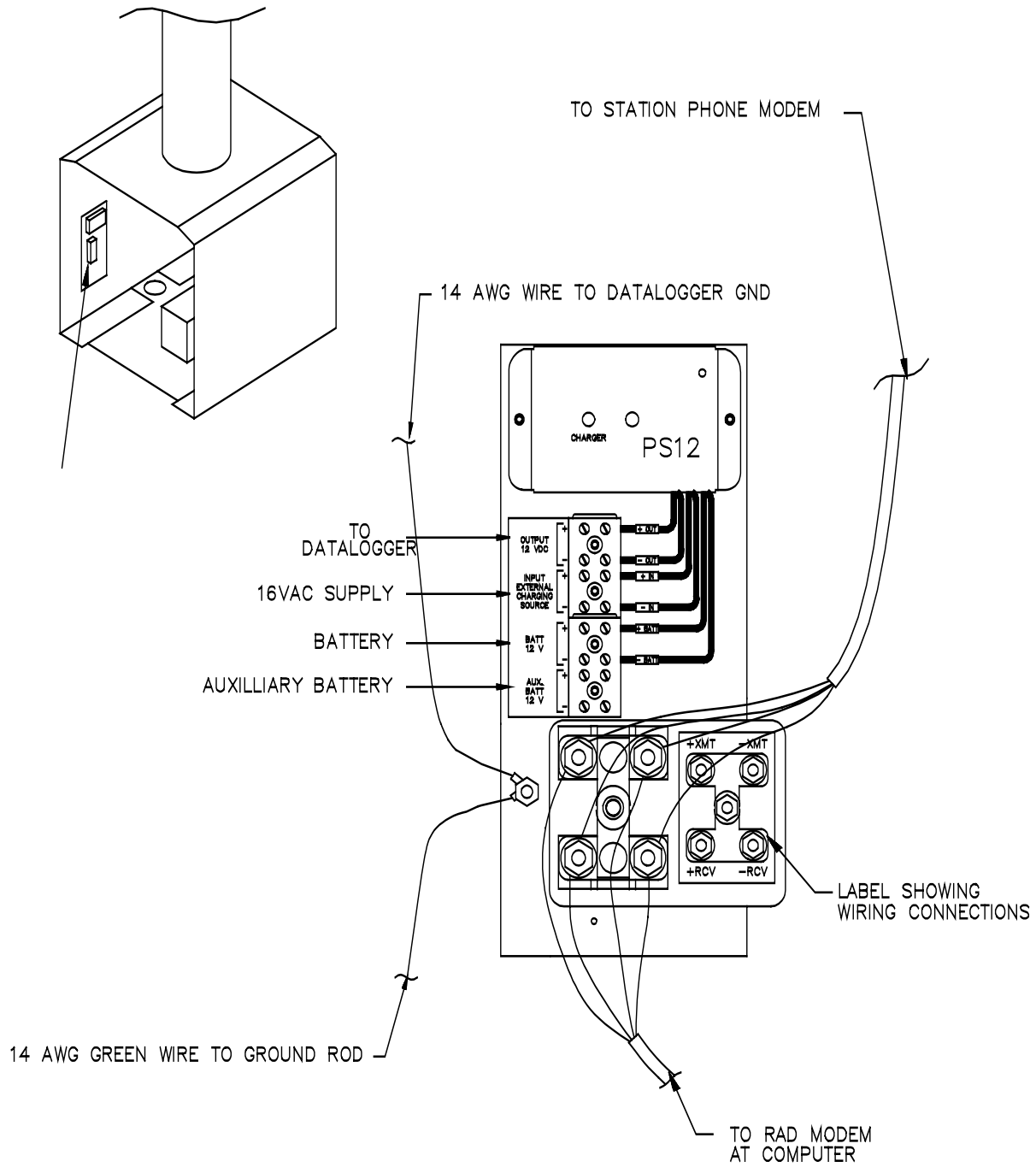

FIGURE 2.6-1. RAD Modem Connections

SECTION 2. WEATHER STATION INSTALLATION

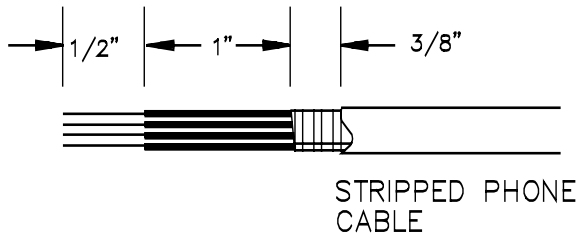
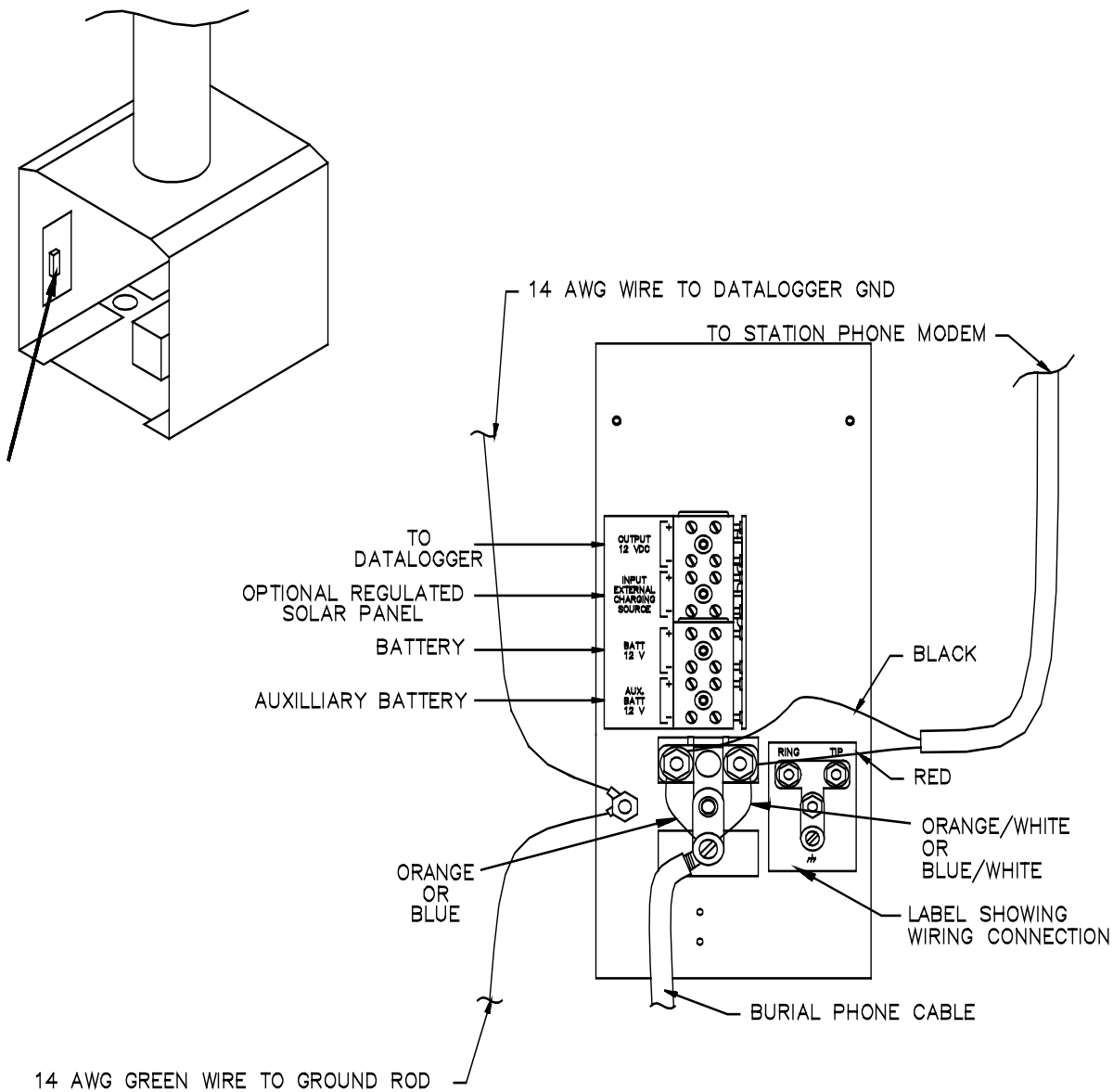

FIGURE 2.6-2. Phone Modem Connections

SECTION 2. WEATHER STATION INSTALLATION

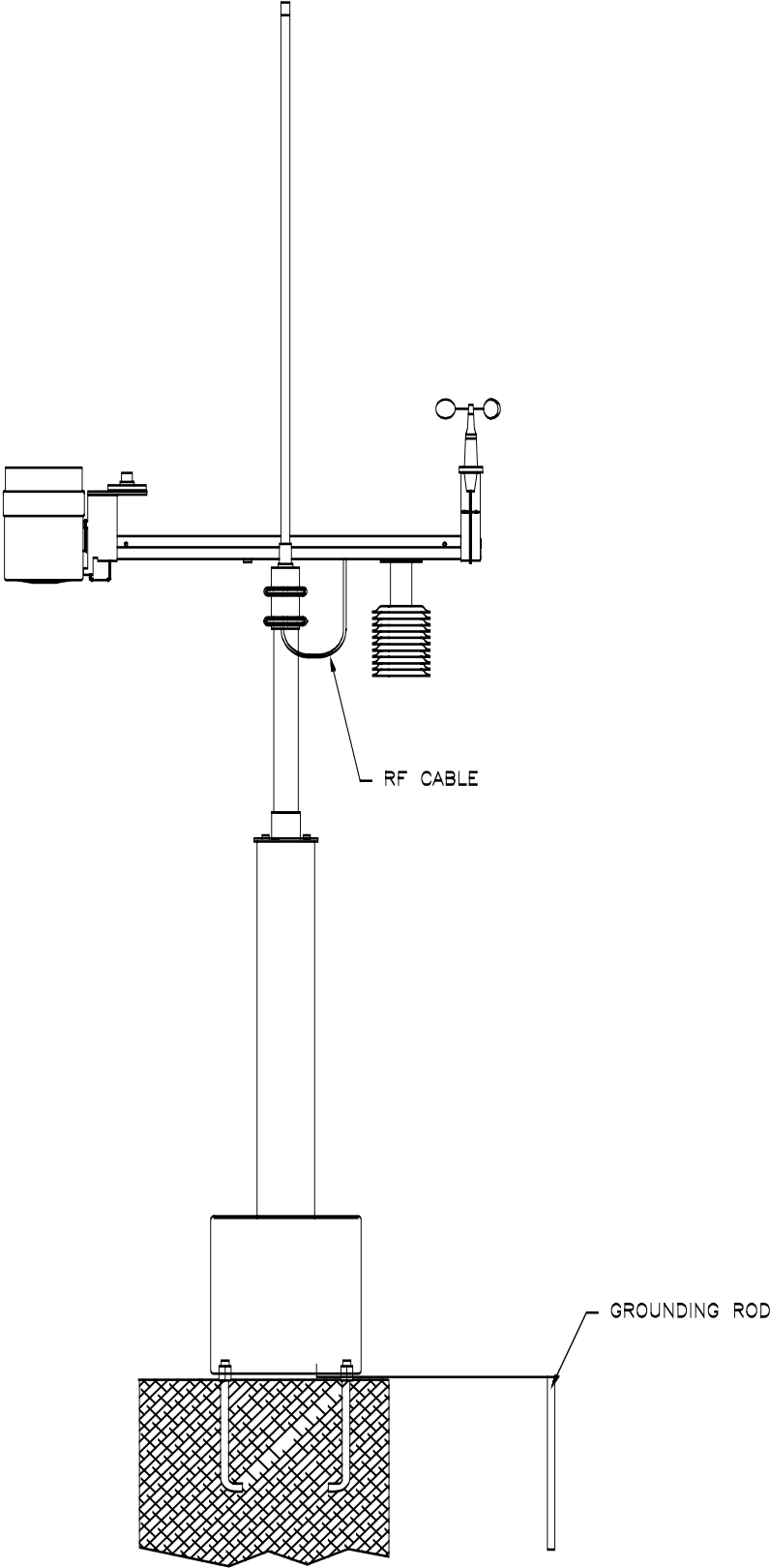

FIGURE 2.6-3. 012 Weather Station with Radio Antenna

SECTION 2. WEATHER STATION INSTALLATION

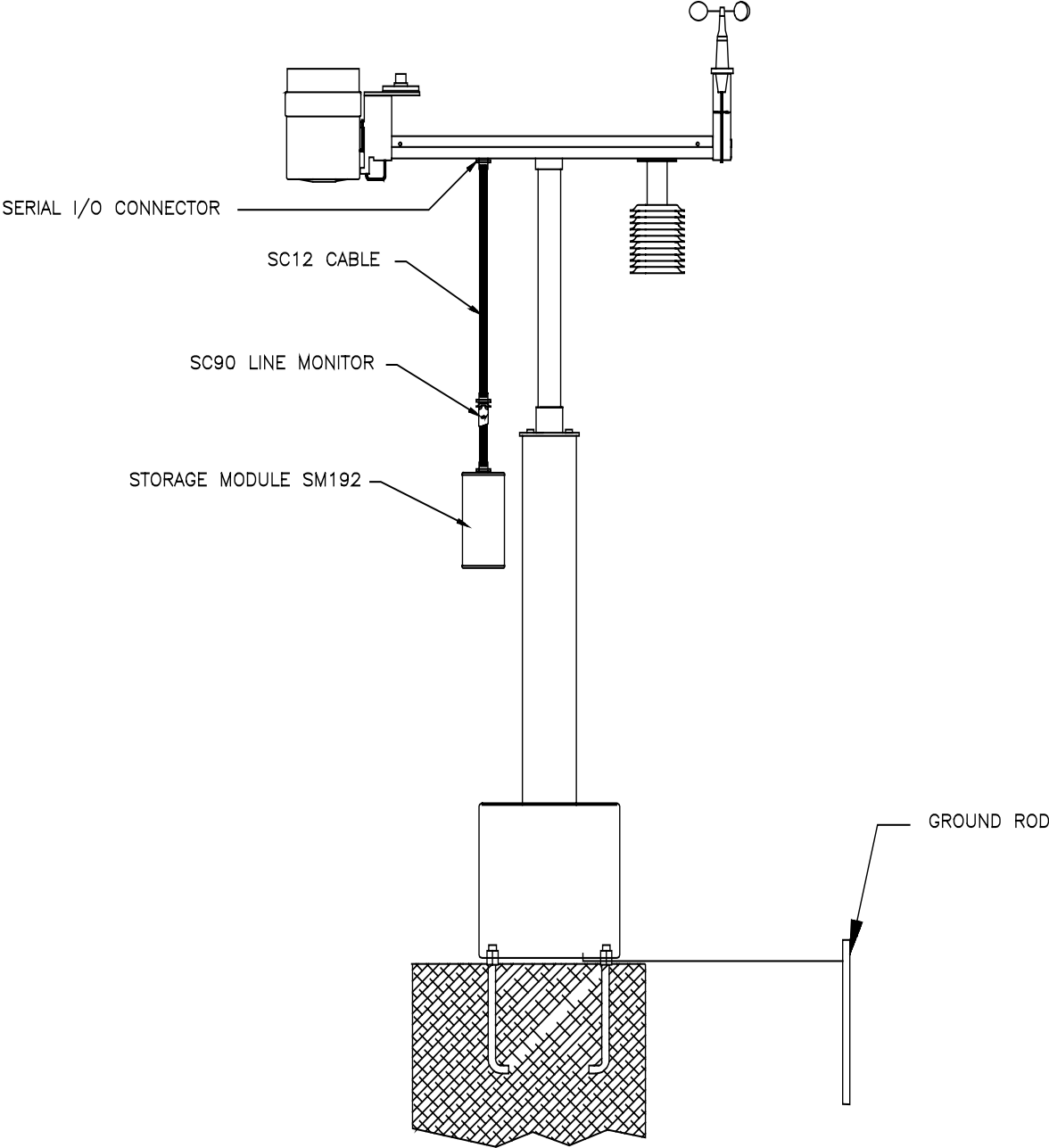

FIGURE 2.6-4. 012 Weather Station with Storage Module

SECTION 2. WEATHER STATION INSTALLATION

TABLE 2.7-1. Sensor Verification; Accessing CR10 Input Locations

<u>Description</u>	<u>Units</u>	<u>Input Location</u>	<u>Keyboard Entry</u>
Battery Voltage*	Volts	1	*6A
CR10 Temperature	°C	2	*62A
Canister Moisture**	0-1000	3	*63A
Ambient Temperature	°C	4	*64A
Ambient Temperature	°F	5	*65A
Relative Humidity	%RH	6	*66A
Solar Radiation ¹	kW/m ²	7	*67A
Wind Speed	mph	8	*68A
Wind Direction ²	degree	9	*69A
Precipitation	inches	10	*610A
Soil Temperature***	°F	11	*611A

2.7 SENSOR VERIFICATION USING THE CR10KD KEYBOARD DISPLAY

The following steps allow verification of the sensor measurements performed every 10 seconds.

Connect the CR10KD Keyboard Display to the serial I/O connector in the crossarm (refer to Figure 2.6-4) using the Model SC12 cable. Upon connection, the display activates, showing meaningless numbers. Enter *0 and the display should show LOG1. The sensor measurements are stored in the CR10's Input Locations, accessed through the *6 Mode; refer to the keyboard entry column in Table 2.7-1. If you get lost or make a mistake, start over by entering *6. Once you are in *6 the A key may be used to advance through the locations and the B key may be used to backup through the locations.

***NOTE:** Due to reverse polarity protection diodes in the circuit, the battery voltage measurement is approximately .7 volts lower than the actual battery voltage. Minimum operating voltage for the CR10 is 9.6 V.

****WARNING:** Readings above 200 indicate high humidity inside the canister. The canister must be opened and dried, and the desiccant reactivated by heating at 250° for 12 hours.

1. Typical values should be between 300 (overcast) and 1000 (bright sunshine).
2. To check the wind vane, point it to the east and compare new reading to 90°.

*****NOTE:** Soil temperature readings are made only if the CR10 User Flag #1 is set high. Refer to Section 2.9 for details.

2.8 SETTING THE CLOCK WITH THE CR10KD KEYBOARD DISPLAY

To set the year, day of year, and time, enter *5 and advance the display to the appropriate window (refer to Table 2.8). Key in the desired value and enter it by pressing the A key. When a new value for hours and minutes is entered, the seconds are set to zero and current time is again displayed. Figure 2.8 shows a day of year calendar.

TABLE 2.8. Sequence of Time Parameters in *5 Mode

<u>Key</u>	<u>Display</u>	<u>Description</u>
*5	:HH:MM:SS	Display current time in hours, minutes, and seconds
A	05:XX	Display/enter year
A	05:XXXX	Display/enter day of year
A	05:HH:MM	Display/enter hours:minutes in military time

SECTION 2. WEATHER STATION INSTALLATION

During leap year add 1 to day 60 (March 1st) through day 365.

FIGURE 2.8. Day of Year Calendar

An example of entering year 89, day 100, and time 1437 is shown below:

<u>Key</u>	<u>Display</u>	<u>Description</u>
*5	Current CR10 time	if time has not been set, time since power up is shown
A	05:XX	display year
89	05:89	key in correct year
A	05:XXXX	enter correct year and display day of year
100	05:100	key in correct day of year
A	05:HH:MM	enter correct day of year and display hours and minutes
1437	05:14:37	key in correct time
A	:14:37:00	enter correct time and display time

Verify that the year, day and time are entered correctly by entering the *5 mode and advancing to each location:

<u>Key</u>	<u>Display</u>	<u>Description</u>
*5	:14:37:15	display hour, minutes, and seconds
A	05:89	display year
A	05:100	display day of year
A	05:14:37	display hour and minutes
A	:14:37:20	return to the original display of hours, minutes, and seconds

Leave the clock mode (*5) and return to the Log Mode by keying *0.

SECTION 2. WEATHER STATION INSTALLATION

2.9 SETTING FLAG 1 TO ENABLE SOIL TEMPERATURE MEASUREMENTS

The optional soil temperature probe is read only if Flag 1 is set high.

To set Flag 1, enter * 6 11 A. The display reads **11:XXXXX**, where XXXXX represents the contents of Input Location 11. Press the **D** key and the display reads **00:000000**. The zeros, from left to right, show that Flags 1 through 8 are not set. To set Flag 1 press **1**. The display reads **10:000000**. Return to Input Location 11 by pressing the A key. A soil temperature reading appears in 10 seconds or less.

If the soil temperature measurement is performed when no probe is connected, the value **-53.46** is recorded. Follow the same procedure as outlined above to reset Flag 1 and disable the measurement.

SECTION 3. PROGRAMMING

The CR10 Measurement and Control Module begins executing the program stored in its PROM when power is connected to the weather station. This "program-on-power-up" function is not found in standard CR10s where users enter their own programs. Users desiring additional sensors or outputs different from this "standard" program may create their own program and overwrite the existing one.

The resident program listed in Appendix A measures wind speed, wind direction, air temperature, relative humidity, solar radiation, and rain every 10 seconds. Soil temperature is measured only if enabled by the user; Flag 1 = 1 (Section 2.9).

The program stores hourly, daily and conditional data as shown below.

TABLE 3-1. 012 Standard Program Outputs

<u>Hourly Output</u>	<u>24 Hour Output</u>
01: Array ID 129	01: Array ID 139
02: Day	02: Day
03: Hour, Minute	03: Hour, Minute
04: Avg. Temperature (F)	04: Avg. Temperature (F)
05: Instantaneous RH (%)	05: Maximum Air Temperature (F)
06: Avg. Solar Radiation (kW/m ²)	06: Minimum Air Temperature (F)
07: Avg. Wind Speed (mph)	07: Maximum Relative Humidity
08: Wind Speed Weighted Avg. Dir.	08: Minimum Relative Humidity
09: Standard Deviation of Wind Dir.	09: Avg. Solar Radiation (kW/m ²)
optional (Flag 1 set high)	10: Maximum Wind Speed (mph)
10: Soil Temperature (F)	11: Avg. Wind Speed (mph)
 <u>Conditional Output</u>	12: Total Rain Fall (inches)
1 Minute Rain Fall Intensity	13: Maximum Internal Moisture Index
01: Array ID 124	14: Sample Battery Voltage
02: Hour, Minute	15: Maximum CR10 Temperature (C)
03: Rain Fall (inches)	16: Minimum CR10 Temperature (C)
	optional (Flag 1 set high)
	17: Maximum Soil Temperature (F)
	18: Minimum Soil Temperature (F)

Appendix A is a listing of the resident program.

3.1 PROGRAMMING SENSOR MEASUREMENTS

The instructions used to measure and convert sensor signals to the values displayed in Input Memory (*6 Mode) are discussed in the following pages. The standard sensors are assigned fixed CR10 Input Channels and Excitation Ports. These and other measurement parameters used in the program are summarized in Table 3-2.

SECTION 3. PROGRAMMING

TABLE 3-2. Parameters for Sensor Measurement Instruction

<u>Sensor</u>	<u>Measurement</u>	<u>Instr. No.</u>	<u>Input Ch.</u>	<u>Input Code</u>	<u>Range mV</u>	<u>Excit Ch</u>	<u>mV</u>
Temperature	AC Half Bridge	11	1S	N/A	N/A	1	2000
Relative Humidity	DC Half Bridge	4	4S	5	2500	2	0000
Solar Radiation	Diff. Voltage	2	3D	2	7.5	N/A	N/A
Wind Speed	Frequency (AC Magnetic)	3	1	N/A	N/A	N/A	N/A
Wind Direction	Half Bridge	4	3S	5	2500	2	2500
Rain	Contact Closure	3	2	N/A	N/A	N/A	N/A
Moisture Index	AC Half Bridge	5	12S	13	25	3	2500

S = Single Ended Analog Channel
D = Differential Analog Channel

3.1.1. TEMPERATURE AND RELATIVE HUMIDITY

The thermistor is read using Instruction 11. The RH sensor is read using Instructions 20 and 4. Instruction 20 switches 12 V to the RH sensor; Instruction 4 delays 80 ms then makes the measurement. Instruction 20 is used again to switch the 12 V off. Instructions 37 and 34 convert the temperature to degrees F and put it into location 5.

- 03: P11 Temp 107 Probe
- 01: 1 Rep
- 02: 1 IN Chan
- 03: 1 Excite all reps w/EXchan 1
- 04: 4 Loc [:temp C]
- 05: 1 Mult
- 06: 0 Offset

- 04: P37 Z=X*F
- 01: 4 X Loc temp C

- 02: 1.8 F
- 03: 5 Z Loc [:temp F]

- 05: P34 Z=X+F
- 01: 5 X Loc temp F
- 02: 32 F
- 03: 5 Z Loc [:temp F]

- 06: P20 Set Port(s)
- 01: 0000 C8..C5=low/low/low/low
- 02: 1000 C4..C1=high/low/low/low

- 07: P4 Excite,Delay,Volt(SE)
- 01: 1 Rep
- 02: 5 2500 mV slow Range
- 03: 7 IN Chan
- 04: 2 Excite all reps w/EXchan 2

- 05: 80 Delay (units .01sec)
- 06: 0000 mV Excitation
- 07: 6 Loc [:RH]
- 08: .1 Mult
- 09: 0 Offset

- 08: P20 Set Port(s)
- 01: 0000 C8..C5=low/low/low/low
- 02: 0000 C4..C1=low/low/low/low

3.1.2 WIND SPEED

The wind speed sensor is read by pulse count Instruction 3, programmed for low level AC and to measure frequency. The relationship between wind speed, ws, and frequency, f, for the R.M. Young Wind Sentry is:

$$ws = 1.677f + 0.4$$

where ws has units of mph and f is in Hz. The result is placed in location 8. If the result equals the anemometer offset (0.4 mph), the wind speed value is set to 0; i.e., when there is no wind speed the offset is not used in the wind vector calculations.

- 10: P3 Pulse
- 01: 1 Rep
- 02: 1 Pulse Input Chan
- 03: 21 Low level AC; Output Hz.
- 04: 8 Loc [:WS mph]
- 05: 1.677 Mult
- 06: .4 Offset

- 11: P89 If X<=>F
- 01: 8 X Loc WS mph
- 02: 1 =
- 03: 4 F
- 04: 30 Then Do

```

12:   P30      Z=F
    01:    0      F
    02:    0      Exponent of 10
    03:    8      Z Loc [:WS mph ]

13:   P95      End
    
```

3.1.3 WIND DIRECTION

The wind direction potentiometer is read using Instruction 4 and the result placed in Location 9. The measurement is delayed 20 ms longer than normal after applying the excitation. The potentiometer has a 5° deadband between 355 and 360°; measurements in this region are acceptable because they are close to 0. The multiplier is $355/2500 = 0.142^\circ/\text{mV}$. The offset is zero.

The wind direction sensor is mounted such that a 0° reading occurs for an east direction; 90° is added to each measurement and 360° subtracted if the result exceeds 360°.

```

14:   P4      Excite,Delay,Volt(SE)
    01:    1      Rep
    02:    5      500 mV slow Range
    03:    3      IN Chan
    04:    2      Excite all reps w/EXchan 2
    05:    2      Delay (units .01sec)
    06: 2500      mV Excitation
    07:    9      Loc [:Wind Dir ]
    08:   .142    Mult
    09:    0      Offset

15:   P34      Z=X+F
    01:    9      X Loc Wind Dir
    02:   90      F
    03:    9      Z Loc [:Wind Dir ]

16:   P89      If X<=>F
    01:    9      X Loc Wind Dir
    02:    3      >=
    03: 360      F
    04:   30      Then Do

17:   P34      Z=X+F
    01:    9      X Loc Wind Dir
    02: - 360      F
    03:    9      Z Loc [:Wind Dir ]

18:   P95      End
    
```

3.1.4 RAIN GAGE

Instruction 3 is used to read the switch closure from the tipping bucket rain gage; 1/100 of an inch of rain per tip.

```

19:   P3      Pulse
    01:    1      Rep
    02:    2      Pulse Input Chan
    03:    2      Switch closure
    04:   10      Loc [:Rain Fall]
    05:   .01     Mult
    06:    0      Offset
    
```

3.1.5 SOLAR RADIATION

Instruction 2 is used to obtain a differential voltage measurement and place the result in Location 7 in units of kWm^{-2} . The solar sensor output is trimmed with a potentiometer to provide a constant multiplier of $0.2 \text{ kWm}^{-2}/\text{mV}$ for all units.

```

09:   P2      Volt (DIFF)
    01:    1      Rep
    02:    2      7.5 mV slow Range
    03:    3      IN Chan
    04:    7      Loc [:kW/m2 ]
    05:    2      Mult
    06:    0      Offset
    
```

3.1.6 INTERNAL MOISTURE DETECTION SENSOR

The moisture sensor is used to detect humidities above 33% inside the canister (electronics). The value stored in Location 3 ranges from 0 to 1000 for dry to wet when programmed as shown below.

```

23:   P5      AC Half Bridge
    01:    1      Rep
    02:   13      25 mV fast Range
    03:   12      IN Chan
    04:    3      Excite all reps w/EXchan 3
    05: 2500      mV Excitation
    06:    3      Loc [:moisture ]
    07: 201      Mult
    08:    0      Offset

24:   P37      Z=X*F
    01:    3      X Loc moisture
    02: 1000      F
    03:    3      Z Loc [:moisture ]

25:   P45      Z=INT(X)
    01:    3      X Loc moisture
    02:    3      Z Loc [:moisture ]
    
```

SECTION 3. PROGRAMMING

3.2 PC208 DATALOGGER SUPPORT SOFTWARE

The PC208 Datalogger Support Software is used for interactive telecommunication between the weather station and the computer. The PC208 software has five software programs: TELCOM, GraphTerm, EDLOG, SPLIT, and SMCOM. Detailed information on each of these programs is found in the PC208 instruction manual.

TELCOM

TELCOM automates data retrieval from the weather station over a communication link. The creation of a station file to specify the communication link, data file name and format, and the calling schedule is menu driven.

GraphTerm

GraphTerm is a terminal emulator program for remote monitoring and displaying of data, downloading and uploading datalogger programs, and remote keyboard entry. Datalogger type, interface option and baud rate are specified and saved in a station file similar to that created in Telcom.

EDLOG

EDLOG is used to develop and document datalogger programs. Once this program is saved TERM can download it to the weather station.

SPLIT

SPLIT is a general purpose data reduction program that operates on data produced by the weather station. SPLIT can select data from one or more files, process and/or combine the data and generate a titled report with labeled data columns.

SMCOM

SMCOM (Storage Module Communications Software) establishes communication with the SM192 and SM716 Storage Modules for retrieving and storing data on disk, as well as for storing and retrieving datalogger programs. SMCOM provides prompts requesting information from the user.

SECTION 4. MAINTENANCE

4.1 MOISTURE IN CANISTER

The hex bolts used to seal the top and bottom of the canister should be tightened every spring and fall to maintain seal integrity. As a guideline, the bolts should be tightened to about 160 inch pounds.

The readings from a moisture detection sensor housed in the canister are displayed in Location 3 and accessed by keying *63A (Section 2.7). The sensor detects humidity above 33% with 0 dry and readings in the 100s being wet. The readings should be monitored regularly and if they are above 200, the weather station must be dried out.

WARNING: Damage to the CR10, modem, and wiring panel will occur if high moisture levels are not corrected. The weather station should be dried out and the desiccant reactivated when the moisture reading is 200 or greater.

When opening the canister, loosen each hex bolt one half turn until each bolt has been loosened two full turns.

CAUTION: DO NOT REMOVE THE BOLTS FROM THE CANISTER.
Desiccant can be reactivated by placing it in an oven at 250 oF for 16 hours.

4.2 RAIN GAGE

Inspect and clean the rain gage as needed to remove leaves, debris, etc. The rain gage calibration is 0.01 in. per tip. The following check is advised every 6 to 12 months.

Rain Gage Calibration:

1. Secure a metal can that will hold at least one quart of water.
2. Punch a very, very small hole in the bottom of the can.
3. Place the can in the top funnel of the rain gage and pour 16 fluid ounces (1 pint) of water into the can (A 16oz. soft drink bottle

filled to within 2.5 inches of the top may be used for a rough field calibration).

4. If it takes less than 45 minutes for this water to run out, the hole in the can is too large.
5. One hundred tips plus or minus three tips should occur.
6. Adjusting screws are located on the bottom adjacent to the large center drain hole. Adjust both screws the same number of turns. Rotation clockwise increases the number of tips per 16 oz. of water; counter clockwise rotation decreases the number of tips per 16 oz. of water. One half turn of both screws causes a 2% to 3% change.
7. Check and re-level the rain gage lid.

4.3 SOLAR RADIATION

Inspect and clean the pyranometer every two to three months. Dusty environments may require more frequent cleaning. Be careful not to scratch the surface of the sensor. A blast of clean, dry air or a soft bristle, camel hair brush are best used for cleaning the diffuser surface. Recalibration of the radiation sensor is recommended every two (2) years.

4.4 WIND SPEED AND DIRECTION

Inspect the operation of the anemometer and windvane bearings at least once a year. They should move freely and react to a windspeed of 2-3 mph. Check the windvane by manually positioning it and verifying the reading.

Components requiring replacement due to normal wear are the precision ball bearings and the azimuth potentiometer. The bearings have a life expectancy of twenty million revolutions (3 to 5 years in normal use). This time may be reduced to 1 year or less in high wind areas. The anemometer bearings should be replaced if they become noisy or if the starting threshold increases above an acceptable level.

CAUTION: DO NOT use WD-40 or other lubricants on the bearings.

SECTION 4. MAINTENANCE

4.5 TEMPERATURE AND RELATIVE HUMIDITY PROBE

The HMP35C Probe requires minimal maintenance. Monthly, check to make sure the radiation shield is free from debris. The screen on the sensor should also be checked as often. Annually, check the calibration of the probe. (It should be sent to CSI if recalibration is needed and facilities to do so are unavailable.)

4.6 BATTERY VOLTAGE

The battery voltage is recorded daily. The battery should be recharged when the voltage is below 11 volts. Incorrect battery voltage readings occur when the battery is low.

Weather stations charging with AC power should check the charging source, transformer, or regulating circuit if the voltage readings are 12 volts or less. A normal charging voltage is around 13.5 volts.

SECTION 5. TROUBLE SHOOTING

The weather station is divided into sensors and the CR10 datalogger for trouble shooting purposes. Appendix B contains sensor specifications and schematics.

5.1 SENSOR TROUBLE SHOOTING

The *6 Mode is used to display current sensor readings (Section 2.7). If an individual sensor reading is incorrect, the sensor circuit should be checked with a VOM (Volt/OHM meter). Appendix B provides wiring schematics of each sensor. All sensors, except for the rain gage, have a measurable resistance. Infinite resistance indicates an open circuit.

NOTE: DO NOT connect an Ohm meter to the temperature and relative humidity probe.

Wind Speed

The resistance of the coil measured between pins 1 and 2 should be between 1100 - 1400 ohms. Infinite resistance indicates the coil is broken; zero resistance indicates a short. Open the sensor and check for moisture or pinched wires.

Wind Direction

The resistance between pins 1 and 2 of the windvane varies from 1 - 11 kohms for a 0-355o direction. A 5o open or "dead" band exists at 355o. The wiper in the potentiometer is most likely damaged if infinite resistance is measured.

The resistance between pins 1 and 3 should always be 10K ohms. Infinite resistance indicates the potentiometer is open and should be replaced.

Rain Gage

The rain gage has a reed switch that closes as the bucket tips. Connect the ohm meter to pins 1 and 2 and tip the bucket very slowly. The meter display will flutter momentarily as the switch contacts close then reopen. Lack of contact indicates the reed switch should be replaced.

Solar Radiation

The solar radiation sensor should measure between 60 and 100 ohms when the sensor is dark. Check for an open circuit.

Temperature and Relative Humidity (RH)

If you are experiencing problems with the temperature and relative humidity probe, consider the following:

1. Are both the temperature AND the relative humidity readings bad? If so, make sure the radiation shield and sensor endcap are free from debris.
2. Is just the temperature reading bad? Again, make sure the radiation shield and sensor endcap are free from debris.
3. Is just the relative humidity reading bad? In this case, the probe needs to be recalibrated. (Contact CSI if facilities to recalibrate are unavailable.)
4. If 1,2 and 3 prove to be ineffective, contact CSI.

5.2 DATALOGGER TROUBLE SHOOTING

The CR10 (1) measures the sensors, (2) converts the measurements to engineering units, (3) processes the values over a time interval and (4) stores the processed result. If stored data is incorrect, evaluate the current measurements directly using the CR10KD Keyboard Display (Section 2.7).

False battery readings of 9 to 10 volts can be observed in the *6 Mode (*6A, Section 2.7) if the battery voltage falls to 8 volts. If the sensor readings are unreasonable, yet the sensors check out according to Section 5.1, measure the battery voltage independently (Figures 2.5-1 and 2.5-2). Check the charging system if the system has one.

SECTION 5. TROUBLE SHOOTING

The CR10 has a regulated 5 volts which can be measured at the serial I/O connector (Figure 2.6-2) using the VOM. Figure 5.2 represents the connector. The 5 volts, ± 1 millivolt, is measured between sockets 1 (+5V) and 2 (ground). Insert a bent paper clip or similar object into each socket to provide solid connections to the VOM.

High internal moisture will short connections to the datalogger, resulting in erroneous measurements. Refer to Section 4 for action to be taken.

FIGURE 5.2. CR10 Serial I/O Connector