

# WHITE PAPER

## *Voltage Measurement Accuracy, Self-Calibration, and Ratiometric Measurements*



**CAMPBELL SCIENTIFIC, INC.**

815 W. 1800 N. • Logan, Utah 84321-1784 • (435) 753-2342 • FAX (435) 750-9540



# ***Voltage Measurement Accuracy, Self-Calibration, and Ratiometric Measurements***

---

*Accuracy is one of the most significant specifications for a voltage measurement system, and sometimes the most confusing. This application note will hopefully alleviate some of this confusion. Accuracy limitations in voltage measurement systems, self-calibration, and ratiometric measurements are also discussed.*

## **Voltage Measurement Accuracy**

Measurement accuracy, which might be better termed inaccuracy, defines how far from the true value a measurement may be. Measurement precision, or repeatability, refers to the degree of consistency between independent measurements under the same conditions. A person who consistently tells the same story that stretches the truth is precise, but not accurate.

No universal method of specifying voltage measurement accuracy exists, increasing the likelihood of ambiguities. For example, a specification of 0.X% could mean  $\pm 0.X\%$ , or  $\pm(0.X\%)/2$ , or  $+0.X\%$  and  $-0.0\%$ . Most measurement errors are bipolar, meaning the errors can be added or subtracted from the true value. A  $\pm$  before the error term is often included to remove ambiguity regarding bipolar errors. Another source of ambiguity in accuracy specifications is the question "Percent of what?". CSI specifies voltage measurement accuracy as either  $\pm 0.X\%$  of Full-Scale Range (FSR) or  $\pm(0.X\%$  of reading + Offset). The  $\pm 0.X\%$  FSR method is the simplest to test and use, but overestimates errors for inputs that are considerably less than full-scale. The  $\pm(0.X\%$  of reading + Offset) specification better represents the actual instrument performance, but is more complicated to test and use.

Possible ambiguity exists with the definition of full-scale range (FSR). For example, is the FSR 5000 mV or 10,000 mV on a  $\pm 5000$  mV input range? An analog-to-digital converter (ADC) has to span 10,000 mV on a  $\pm 5000$  mV input range, and so CSI has adopted the convention that FSR = 10,000 mV on a  $\pm 5000$  mV input range.

As a rule, voltage measurement accuracy specifications are tested by making low-noise measurements of the output voltage from an

National Institute of Standards and Technology (NIST) traceable calibrator<sup>1</sup>. Sensor errors and/or external measurement noise cannot be practically incorporated into a general purpose instrument accuracy specification. For example, individual samples of a noisy measurement may have errors that exceed the instrument accuracy specification, although the mean value of these measurements should be within the specified accuracy.

The root-mean-square (rms) noise of a system with a constant input is equivalent to the standard deviation, which can be determined using instructions available in CSI dataloggers<sup>2</sup>. The total measurement uncertainty of a system can be obtained by combining the instrument accuracy, sensor accuracy, and measurement noise. Measurement accuracy is usually expressed as peak-to-peak, while noise is usually rms. For a Gaussian (normal) probability distribution, 99% of all possible values are within  $\pm 2.5$  standard deviations of the mean. Consequently, a conversion often assumed is that the peak-to-peak value equals  $2(2.5) = 5$  times the rms value. The instrument accuracy, sensor accuracy, and measurement noise can be combined by adding the individual errors together. This gives a worst-case uncertainty, but it is an overly pessimistic estimate for uncorrelated error components that are unlikely to all be at their maximum value and same polarity at the same time. A more realistic way to combine uncorrelated measurement errors is to use the root-sum-of-squares method<sup>3</sup>. This method takes the square root of the sum of the individual errors squared  $\sqrt{I_a^2 + S_a^2 + M_n^2}$ .

## Self-Calibration

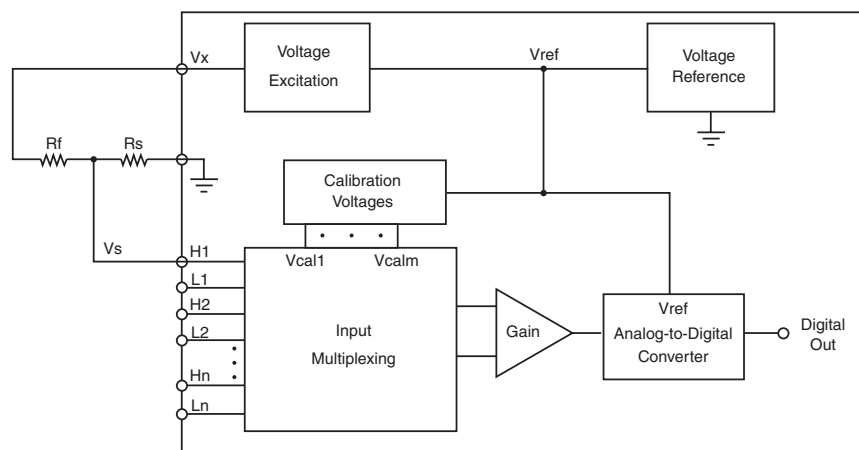

Figure 1. Multiplexed Voltage Measurement System

Fig. 1 shows a block diagram of a multiplexed voltage measurement system with a voltage reference that is used for the analog-to-digital converter (ADC) and also for generating the bridge excitation voltage. With CSI dataloggers, self-calibration voltages are also derived from this measurement voltage reference and are used to remove gain errors for the different input ranges. The measurement voltage reference is factory calibrated to a traceable NIST voltage standard and provides a calibration source for the portable measurement system. This self-calibration is typically done between measurement scans. **Self-calibration, a feature of all CSI dataloggers, significantly improves measurement accuracy by compensating for gain stage and ADC temperature drift, and component aging.**



Campbell Scientific quotes accuracy figures for most products that take into account the combined effects of calibration, linearity, and drift error over an operating temperature range of  $-25^{\circ}$  to  $+50^{\circ}\text{C}$ . This should be considered when comparing products or selecting sensors where often (1) an accuracy figure at one temperature (2) a temperature drift figure and (3) a non-linearity figure are provided as separate specifications.

## Ratiometric Measurements

The accuracy of the measurement system using self-calibration is limited by the temperature drift of the measurement voltage reference. For some types of sensors, this inaccuracy is eliminated by using a ratiometric measurement. In ratiometric measurements, the measured quantity is proportional to a ratio of two voltages rather than an absolute voltage. When both voltages are proportional to the same reference, the absolute value of the reference does not affect the ratio. Resistive bridge measurements are inherently ratiometric, since the unknown sensor resistance is proportional to a ratio of the sensor and excitation voltage ( $V_s/V_x$ ). A ratiometric resistive bridge measurement is illustrated in Fig. 1.

The measured voltage is derived from the resistive voltage divider as

$$V_s = V_x \left( \frac{R_s}{R_s + R_f} \right) \quad (\text{eq. 1})$$

where  $V_s$  is the sensor voltage,  $V_x$  is the excitation voltage,  $R_f$  is a fixed resistance, and  $R_s$  is the sensor resistance.

Solving for  $R_s$  results in:

$$R_s = \frac{R_f}{\left(\frac{V_x}{V_s} - 1\right)} \quad (\text{eq. 2})$$

Both  $V_s$  and  $V_x$  are related to  $V_{\text{ref}}$  as  $V_s = k_s V_{\text{ref}}$  and  $V_x = k_x V_{\text{ref}}$ , where  $k_s$  and  $k_x$  are range dependent gain constants determined from self-calibration.

Substituting these expressions for  $V_x$  and  $V_s$  into Eq. 2 yields:

$$R_s = \frac{R_f}{\left(\frac{k_x}{k_s} - 1\right)} \quad (\text{eq. 3})$$

Eq. 3 illustrates that  $R_s$  is independent of  $V_{\text{ref}}$  in a ratiometric measurement. Errors in the internally generated self-calibration voltages remain in the ratio  $k_s/k_x$ , but these are small. The ratiometric voltage measurement accuracy of CSI dataloggers is typically two to five times better than non-ratiometric measurements, and is often limited by the uncertainty of the external bridge resistors. **Ratiometric measurements provide a powerful technique for the elimination of voltage reference errors.**

## Footnotes and References

1. Outside the USA, Campbell Scientific dataloggers are often calibrated to local national standards, rather than NIST.
2. See CSI application note "Methods of Preventing Measurement Noise Problems."
3. "Guidelines for Evaluating and Expressing the Uncertainty of NIST Measurement Results" Barry N. Taylor and Chris E. Kuyatt, NIST Technical Note 1297 1994 Edition.