

# CM270 Installation

Tools needed:

- 11 mm (7/16-inch) open-ended or socket wrench
- Long #2 Phillips screwdriver

Remove rain gage mounting hardware:

1. Remove the three feet mounted on the bottom of the rain gage.
2. Remove the side bracket, but keep the screws.
3. Place the side-bracket screws into the rain gage and tighten. This keeps debris out of the threaded holes.

Do the following to assemble the mounting bracket.  
FIGURE 1 and FIGURE 2 show the bracket components and proper assembly.

1. Remove the components from the shipping bag. To assemble the bracket, you will need the bottom plate, V-shaped plate, S-shaped plate, three bolts, two leveling springs, and cylindrical spacer. The bottom plate should come with three black nylon grommets in it, and the pole-mounting hardware attached to it.
2. Place the leveling springs over the bottom-plate side grommets.
3. Place the V-shaped plate onto the bottom plate. The V-shaped-plate legs should be on the leveling springs and the bubble level should be next to the pole-mounting hardware.
4. Use two bolts to secure the V-plate legs to the bottom plate (with the springs sandwiched between the two plates). Initially finger tighten the bolts, then use a wrench to further tighten them.

NOTE: Do not compress the springs at this time.

5. Place the cylindrical spacer on the front grommet of the bottom plate.
6. Place the S-shaped plate on the spacer, and use the bolt to secure it to the bottom plate. Initially finger tighten the bolt, then use a wrench to further tighten. Leave it a bit loose.

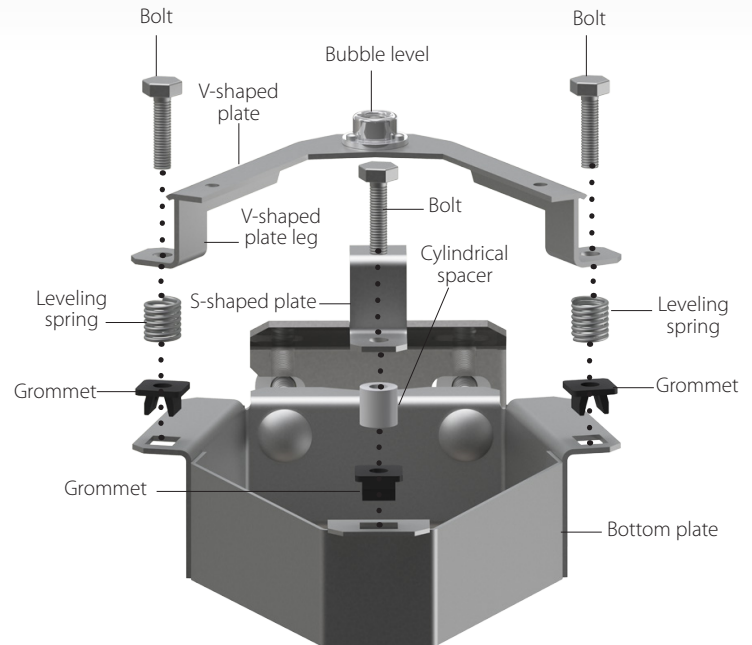

Figure 1: Exploded view of the CM270 Mounting Bracket Kit

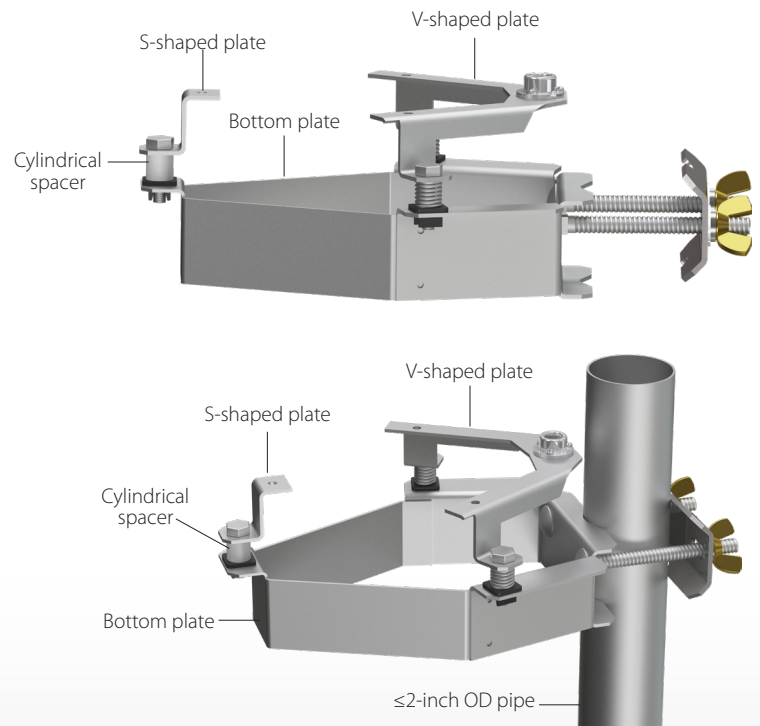

Figure 2: Two views of an assembled CM270

Do the following to mount the tipping-bucket rain gage to the CM270 bracket (FIGURE 3). This procedure needs to be followed to ensure that the tipping bucket is mounted correctly. The adjustment screws for the tipping mechanism will not be accessible if it is mounted incorrectly.

1. Turn the rain gage upside down and set it on a hard surface such as a table top.
2. Place the mounting bracket on the bottom of the bucket. Line up the three holes in the mounting bracket with the three holes used for the mounting feet. When positioned correctly, the tipping-bucket cable will be near the bubble level and pole-mounting hardware.
3. Use three self-tapping screws and a long Phillips screwdriver to securely fasten the mounting bracket to the bottom of the tipping bucket.
4. Turn the assembly over, and tighten the bolt that uses the cylindrical spacer. The bolts securing the leveling springs need to remain loose to allow leveling when the bracket is mounted to the pole or mast.

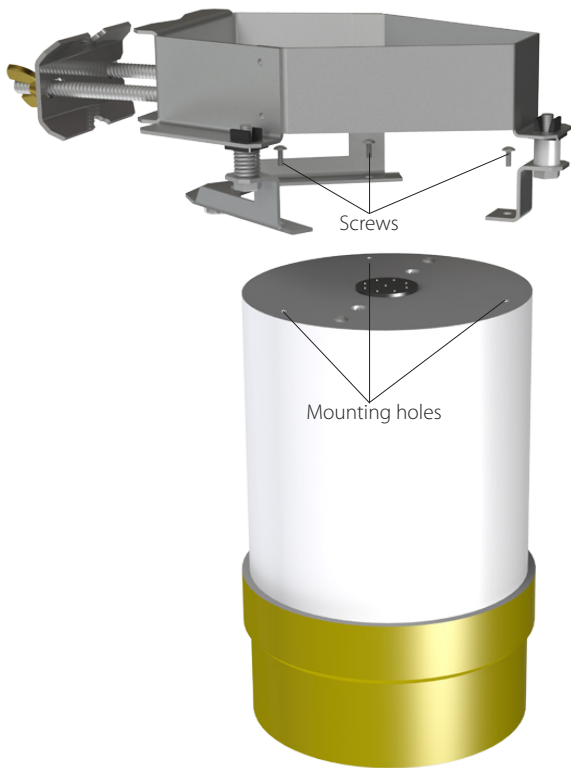

Figure 3. Mounting CM270 to the rain gage

The CM270 is compatible with the CM300-series mounting poles or other poles or masts with an outer diameter of 5 cm (2 inches) or less. Do the following to attach the mounting bracket/tipping bucket assembly to a pole or mast:

1. Install and level the mounting pipe or mast by using J-bolts or self-supporting legs, or by placing the pipe or mast directly into a concrete foundation.
2. Loosen the mounting-bracket wingnuts, and slide the assembly over the pipe. If necessary, the pole mounting hardware can be removed to get the bolts around the pipe. If this is necessary, to reassemble, put the mast clamp on first followed by the flat washers, lock washers, and wingnuts. See FIGURE 4.
3. Tighten the assembly onto the pipe, while ensuring that nothing is blocking the top of the rain gage.
4. Adjust the two bolts on the leveling springs until the bubble in the level is inside the bullseye.

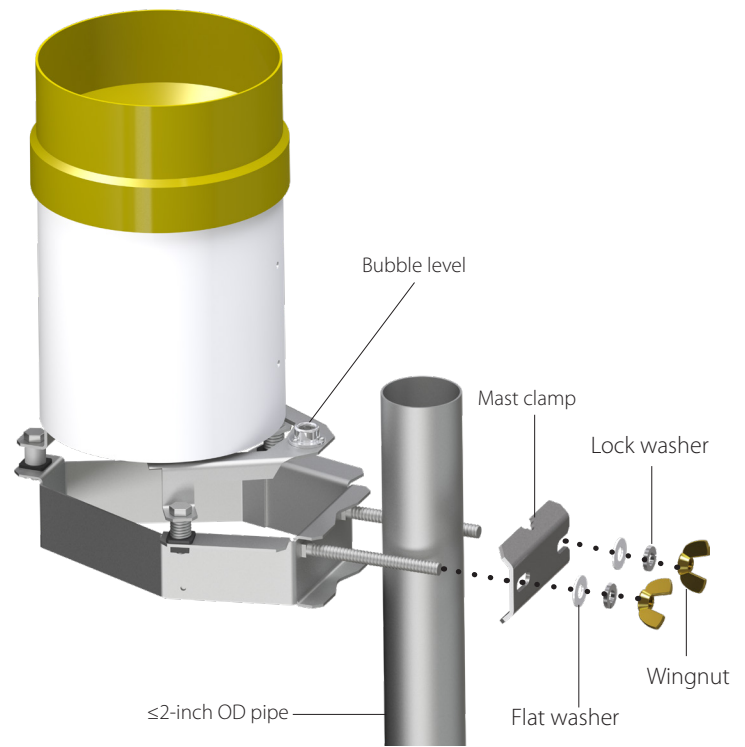

Figure 4. CM270 pipe mounting (exploded view)