

Campbell Scientific

AUTOMATED DATA ACQUISITION SYSTEMS

Campbell Scientific data acquisition systems work in controlled laboratory and rugged vehicle field testing—they work well, and they work for a long time.



Vehicle Testing



Photo courtesy of trcpg

Our Philosophy

Campbell Scientific is the world leader in manufacturing data acquisition (DAQ) systems for monitoring in extreme environments. We care about measurements, so we only manufacture products that give you accurate data. We care about reliability, so we design and test for use in the harshest environments. We care about your success, so we offer continuous support to back you up. Rely on Campbell Scientific when your measurements matter.

Uncompromised *Reliability.* *Accuracy.* *Service.*

With a dedication to accuracy and reliability, the GRANITE Series Data Acquisition System has been designed for vehicle testing in the lab and in the field.

The GRANITE's unique modular design provides a framework to customize each system, so it is ideal for your specific project. Central to each module is its configurability, accuracy, ruggedness, low power requirements, and attractive cost-per-channel ratio.



45
YEARS
1974-2019

Modular

As an independent measurement module, each can be connected directly to a PC or DAQ. Regardless of the number or type of sensor inputs required, the modular design of the GRANITE makes it scalable.

When compatible measurement modules are connected directly to a PC, the SURVEYOR software provides visualization of real-time data and data storage.





Distributed

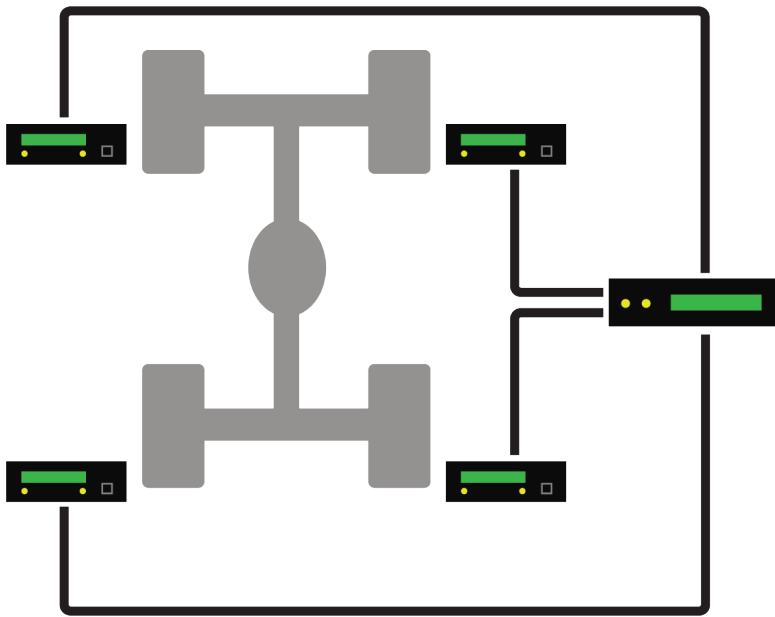

Networks of GRANITE modules are controlled and synchronized by a single GRANITE DAQ. This decreases the amount of cable required for each sensor, resulting in a substantial decrease in overall system costs. Shorter sensor cables also reduce signal corruption from noise.

GRANITE modules can be distributed over thousands of feet within a distributed network.





Synchronization

Synchronization Between DAQs

- Built-In GPS
- Geo-Spatial Synchronization
- Independent DAQ synchronized to within microseconds

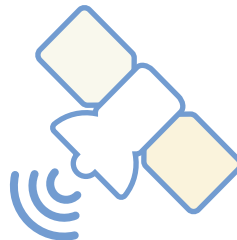

Synchronization within a DAQ

- Time synchronization across modules to within tens of nanoseconds
- On-board temperature-compensated, high-precision, real-time clock

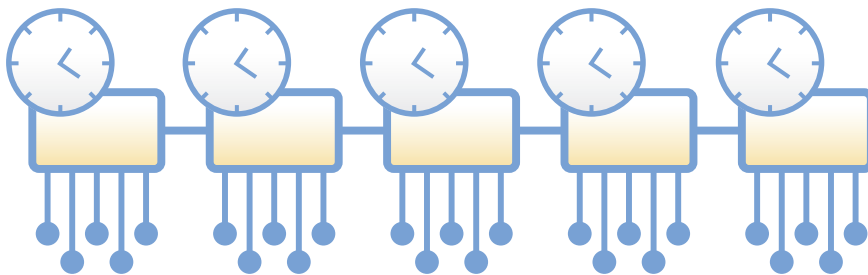

How a Distributed DAQ Lowers the Cost of Vehicle Instrumentation

The cost of instrumenting a vehicle includes installation time, sensors, DAQ hardware, and vehicle modifications. The architecture of the DAQ hardware impacts the cost.

system is that all the sensor connections are housed in a single location. But, the benefits of a distributed DAQ are lower cable costs and vehicle modifications, and quicker installations because you don't have to route as many cables.

A GRANITE DAQ can be a centralized or a distributed system. Or, a combination of both! The advantage of a centralized

| | Central DAQ | Distributed DAQ |
|-----------------------|---|---|
| Cable cost | Thermocouple cable is about \$0.61/ft | Ethernet cable is about \$0.10/ft |
| Vehicle modifications | Often more modifications are required to route a "bundle" of wires, costing more in time and potentially altering vehicle performance | Getting an Ethernet communication cable through the firewall is often possible without modifying the vehicle, saving time and reducing cost without affecting vehicle performance |
| Channel count | Often limited to the DAQ capacity or the backplane capacity | Generally considered more expandable because you're not limited to a dedicated backplane |
| Measurement type | Limited to what is on the DAQ | More flexible because specific measurements can be added with measurement modules |
| Installation type | Easy to install the DAQ; much longer installation time with sensors | DAQ modules require more installation time, but sensor cable routing is much shorter |
| Maintenance | Could be easier to maintain with all the cable connections in a central location | Could be easier to maintain as swapping out a sensor is simpler with less sensor cable routing |
| Advantages | All measurement hardware is in a single location | More easily expanded; lower total cost; measurement modules can be interchanged as needed and shared amongst different DAQs |
| Disadvantages | Limited expandability and higher installation cost on the total system | |

Cost Savings Example

A distributed DAQ in a high-count thermocouple measurement system can eliminate thousands of feet of sensor wire and drastically reduce labor and vehicle modifications. Some users report cable cost savings and reduced labor in excess of \$5,000 per instrumented vehicle.





**CAMPBELL[®]
SCIENTIFIC**



+1 (435) 227-9120 | www.campbellsci.com

AUSTRALIA | BRAZIL | CANADA | CHINA | COSTA RICA | FRANCE | GERMANY | INDIA | SOUTH AFRICA | SPAIN | THAILAND | UK | USA

Copyright © 2020 Campbell Scientific