

# Local Area Datalogger Networks

## Model MD9 Multidrop Interface

The MD9 Multidrop Interfaces\* link a computer to as many as 200 dataloggers (CR510, CR500, CR10(X), 21X, CR23X, and CR7) over a single coaxial cable. Each datalogger in the network is connected to an MD9 that has a unique, user-assigned address. Communication between the computer and a specific datalogger is routed through the MD9's address allowing the rest of the network to remain in quiescent mode. Total coax cable length can be up to three miles; each MD9 in the network slightly reduces the maximum transmission distance (see page 2).

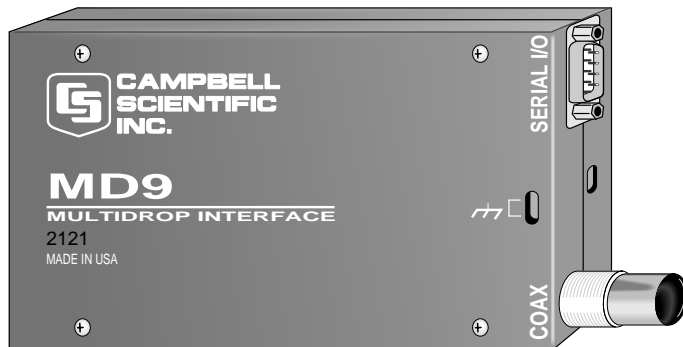

The network is accessed through the computer's serial port. LoggerNet Datalogger Support Software supports station addressing, data retrieval, and monitoring. Remote MD9 networks are accessed by telephone (see page 3) or radio telemetry (contact Campbell Scientific).

### Features

- Cost-effective network of multiple dataloggers connect to a computer via one coaxial cable
- BNC connectors simplify system installation and expansion
- Low current consumption allows remote MD9s to be powered by the datalogger's power supply
- Telecommunications supported at rates up to 9600 baud over a three mile distance

### A Typical Station

The components of a typical data acquisition station fit within a 12" x 14" enclosure. The PS100 supplies 12 Vdc to a CR510, CR500 or CR10(X) datalogger which powers and communicates with the MD9 via the SC12 cable. The coaxial cable is fitted with BNC connectors which attach to a BNC "T" connector at the MD9. The station shown at right is the final station on the cable, as the continuation of the coaxial cable has been replaced by the MD9CT. This device attenuates the signal to prevent it from reflecting back through the coaxial cable and causing interference.

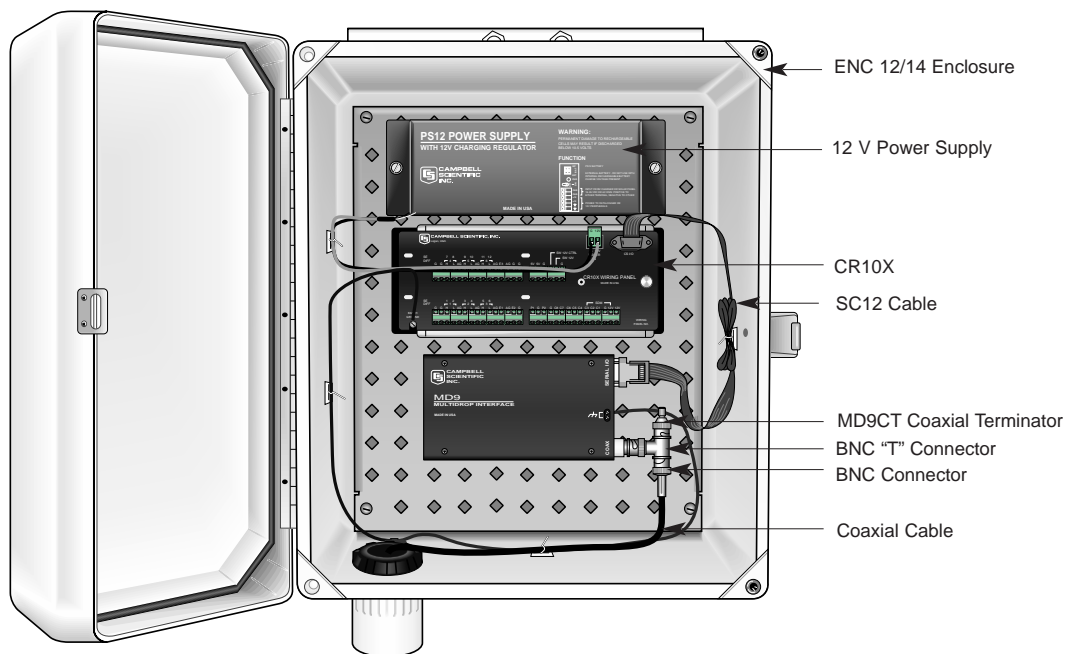

\*The MD9 cannot be used in an MD485 network.



**CAMPBELL SCIENTIFIC, INC.**

815 W. 1800 N. • Logan, Utah 84321-1784 • (435) 753-2342 • FAX (435) 750-9540 • [www.campbellsci.com](http://www.campbellsci.com)

## MD9 Network Configuration

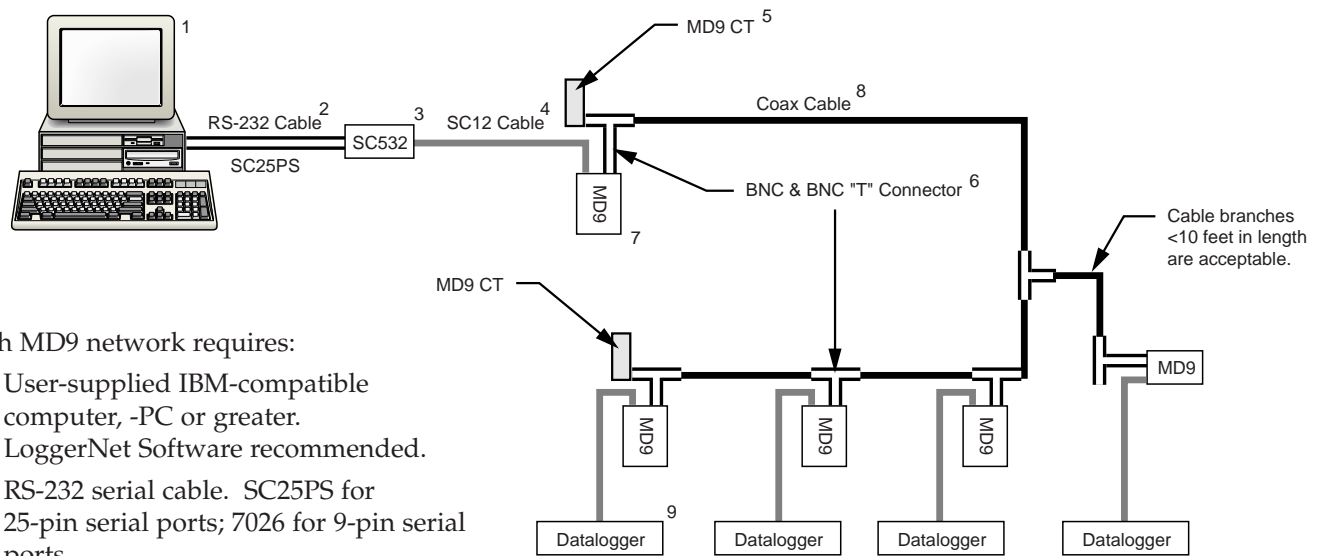

Each MD9 network requires:

- 1) User-supplied IBM-compatible computer, -PC or greater. LoggerNet Software recommended.
- 2) RS-232 serial cable. SC25PS for 25-pin serial ports; 7026 for 9-pin serial ports.
- 3) SC532(A) Interface. Converts to RS-232 logic.
- 4) SC12 9-pin Serial Cable; provided with MD9.
- 5) MD9 CT Coax Terminator (75 Ohm). Sold in pairs; one required at each end of cable.
- 6) BNC "T" connectors. Provided with MD9.
- 7) MD9 Multidrop Interface. One at computer and one at each datalogger in the network.
- 8) User-supplied coaxial cable. RG59/U (Belden Model #9100 recommended). Requires user-attached BNC connector at each junction. Alternatively, completed "sections" of cable or RG59/U cable (cut to length) and BNC connectors can be ordered from Campbell Scientific.
- 9) CSI's CR510, CR500, CR10(X), 21X, CR23X or CR7. A 12 Vdc power supply is required; an environmental enclosure is typically used.

## Network Design Considerations

Signal loss due to the number of MD9's, the cable, and the coax terminators affects the quality of the communication signal. To maintain a signal suitable for data transmission, the network signal loss cannot exceed 50 dB. The signal is attenuated 0.2 dB by each MD9 and 6 dB by the terminator pair. Signal loss due to the cable varies with cable type and quality. Typically, cables with low attenuation are more expensive.

Example:

For a system with 100 MD9s, the MD9s introduce an attenuation of:

$$\begin{aligned}
 \text{MD9 attenuation} &= (\text{number of MD9s}) (0.2 \text{ dB}) \\
 &= 100 \times 0.2 \text{ dB} \\
 &= 20 \text{ dB}
 \end{aligned}$$

The two terminators add another 6 dB loss. Because the network signal loss cannot exceed 50 dB, the signal loss of the cable cannot exceed:

$$\begin{aligned}
 \text{Cable loss} &= 50 \text{ dB} - (20 \text{ dB} + 6 \text{ dB}) \\
 &= 24 \text{ dB}
 \end{aligned}$$

If a cable with an attenuation of 0.6 dB/100 ft is used, the maximum cable length that can be used is:

$$\begin{aligned}
 \text{Max length} &= (24 \text{ dB}) / (0.6 \text{ dB}/100 \text{ ft}) \\
 &= 4000 \text{ ft}
 \end{aligned}$$

## Telephone-to-MD9 Network

A telephone-to-MD9 system combines the advantages of multidrop and telephone telemetry. Telephone access allows the multidrop system to be a large distance from the base station computer; the three-mile limitation on the length of the coaxial cable can exclude the computer-to-first-MD9 segment. The combination also allows a single phone line to access to all of the dataloggers on the coaxial cable therefore saving the expense of individual phone lines.

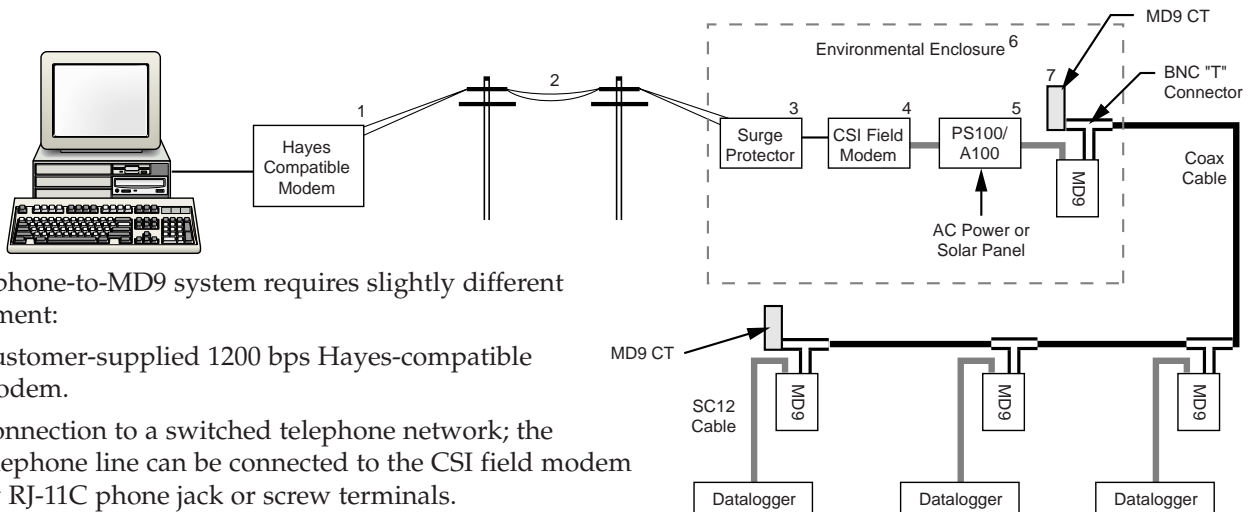

A telephone-to-MD9 system requires slightly different equipment:

- 1) Customer-supplied 1200 bps Hayes-compatible modem.
- 2) Connection to a switched telephone network; the telephone line can be connected to the CSI field modem by RJ-11C phone jack or screw terminals.
- 3) 6362 (for use with enclosure) or 2372-01 Joslyn Telephone Surge Protector. Required if the telephone company does not install a surge protector.
- 4) CSI Field Telephone Modem; includes SC12 cables. Dataloggers purchased before 12/97 may require an adapter to work with our COM200 or COM210 modem; contact factory for details.
- 5) PS100/A100 combination provides a power supply with charging regulator and null modem ports. Recharge by ac power or a solar panel is required.

Remainder of system is identical to an MD9 network without a telephone link.

## Compatibility

- Dataloggers
- all CR510, CR500, CR10(X), and CR23X dataloggers
  - 21Xs with serial numbers 6195 or higher (others require factory modification)
  - 700X Control Module serial numbers 1670 or higher (others require factory modification)
- Software
- LoggerNet or PC208(W) Software; PC208 must be version #5348-00 or higher (an upgraded version can be purchased)
- Cable
- RG-59/U Coax (e.g., Belden Model 9100 with typical attenuation of 0.6 dB/100 ft at 1 MHz)

## Specifications

- Baud rate: 9600, 1200, 300; hardware selectable
- Current drain: 1.2 mA quiescent  
80.0 mA active
- Operating voltage: 5 Vdc from the PS100 or SC532(A) Interface
- Carrier frequency: 1.2 MHz
- Operating temperature range: -25° to +50°C
- Size: 6.5" x 3.5" x 1.25"
- Weight/shipping: 5 oz/2 lbs
- MD9 shipped with: SC12 cable and BNC "T" connector



**CAMPBELL SCIENTIFIC, INC.**

815 W. 1800 N. • Logan, Utah 84321-1784 • (435) 753-2342 • FAX (435) 750-9540  
Offices also located in: Australia • Brazil • Canada • England • France • South Africa • Spain

Copyright © 1990, 2004  
Campbell Scientific, Inc.  
Printed January 2004