

Operating instructions
Manuel d'utilisation
Bedienungsanleitung
Käyttöohje

HMP 35A & HMP 35D



Humidity and
temperature probes

Meßsonden für Feuchte
und Temperatur

Sondes de mesure de
température et d'humidité

Kosteus- ja lämpötila-
mittapää

Doc. no. HMP35A-O0217-2.1

Operating instructions

HMP 35A and HMP 35D humidity and temperature probes

1. PRODUCT DESCRIPTION AND OPERATION

The HMP 35A and HMP 35D probes are designed for measurement of relative humidity and temperature. Humidity measurement is based on the latest HUMICAP® sensor, the H-sensor. Both the humidity and temperature sensors are located at the tip of the probes and protected by a membrane filter. The probes can be connected to several measurement systems and devices, including:

- weather stations
- dataloggers
- recorders
- controllers
- displays
- laboratory equipment.

2. CONNECTIONS

The cable wires are connected as shown in Figures 3 and 4.

3. CALIBRATION AND MAINTENANCE

Calibration and maintenance of the probes should be performed at regular intervals, at least once a year or

more often, depending on the conditions of use and desired accuracy. A one-point calibration may be performed for the probes during actual measurement by adjusting the trimmer potentiometer marked "DRY" in the probe shaft. The field calibration can be performed against a calibrated Vaisala humidity meter. For a high-accuracy two-point calibration use a Vaisala HMK 11 calibrator and saturated salt solutions as described in the HMK 11 Operating Manual. The calibration is first done for the dry end and then for the wet end by adjusting trimmer potentiometers marked "DRY" and "WET". The potentiometers are located under a protective plug in the probe handle, see Figure 3. (Note: the minimum output signal of 0.002 V corresponds to a relative humidity of 0.2 %RH.)

Replacing the H-sensor

Detach the damaged sensor and replace it with a new one. Handle the sensor with care. Calibrate the probe, preferably using two-point calibration, before taking it into use.

Chemical tolerances of the H-sensor

Long-term exposure of the sensor to certain chemicals and gases may shorten sensor life and change its properties. The following list give suggested maximum ambient concentrations for some typical chemicals:

- | | | |
|----|--|-----------------------------|
| 1. | Organic solvents | 1000...10 000 ppm (typ.) |
| 2. | Aggressive chemicals
(e.g. strong acids such
as SO ₂ , H ₂ SO ₄ , H ₂ S,
HCl, Cl ₂ , etc.) | 1...10 ppm (typ.) |
| 3. | Weak acids | 100...1000 ppm (typ.) |
| 4. | Bases | 10 000...100 000 ppm (typ.) |

Detailed information on allowed concentrations is available on request from your Vaisala representative.

4. SPARE PARTS AND ACCESSORIES

HMK 11 calibrator
Radiation shield

HMP 35A

HUMICAP® H-sensor	0062
Temperature sensor Pt 100 (1/3 DIN 43760B)	10429
Membrane filter	2787
Sintered filter 37 µm	6685
Sintered filter 216 µm	6686
Plastic grid	6597

HMP 35D

HUMICAP® H-sensor	0062
Temperature sensor Pt 100 (1/3 DIN 43760B)	10429
Membrane filter, chromium-plated	16126
Sintered filter 37 µm	6685
Sintered filter 216 µm	6686

5. TECHNICAL SPECIFICATIONS

HMP 35A & HMP 35D

Measurement range	0 ... 100 %RH
Output signal range	0.002 ... 1 VDC (equals 0.2 ... 100 %RH)
Accuracy at +20 °C (including nonlinearity and hysteresis)	
• against factory references	± %RH
• against field references	±2 %RH (0 .. 90 %RH) ±3 %RH (90 .. 100 %RH)

Temperature dependence	± 0.04 %RH/°C
Typical long-term stability	better than 1 %RH per year
Response time (at 20 °C, 90 % response)	15 s with membrane filter
Settling time	1 s
Sensor	HUMICAP® H-sensor (part no. 0062)
Temperature sensor	Pt 100 (1/3 DIN 43760B, four-wire connection)
Supply voltage	7 ... 35 VDC
Current consumption	≤ 4 mA
Operating temperature	-40 ... +60 °C
Protection class	IP 55 (NEMA 3S) IP 65 (NEMA 4) *
Weight	180 g
Accessories	radiation shield

HMP 35A

Sensor protection

- standard membrane filter
(part no. 2787)
- optional plastic grid (part no. 6597)
sintered filter 37 μm
(part no. 6685)
sintered filter 216 μm
(part no. 6686)

Housing material

ABS plastic

Cable length

1600 mm

HMP 35D

E.M.I. protection

IEC 801-3 standard, level 2

Sensor protection

- standard membrane filter,
chromium-plated (part no.
2787)

Sensor protection	
• optional	sintered filter 37 μm (part no. 6685) sintered filter 216 μm (part no. 6686)
Housing material	chromium-plated ABS plastic
Cable length	3500 mm

(* For details, consult your Vaisala representative.)

Information and specifications in this manual subject to change without prior notice.

Copyright Vaisala Oy, 1991.

HUMICAP® is a registered trademark of Vaisala.

Fig. 2 One-point calibration
Fig. 2 Etalonnage 1 point
Bild 2 Einpunkt-Kalibrierung
Kuva 2 Yhdenpisteen kalibrointi

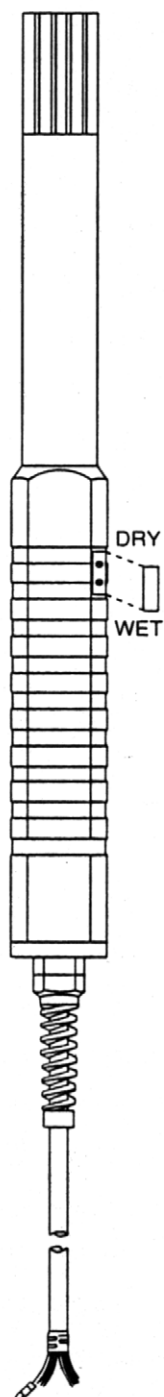

HMP 35A

- Fig. 3** Electrical connections
Fig. 3 Connexions électriques
Bild 3 Elektrische Anschlüsse
Kuva 3 Sähköiset liitännät

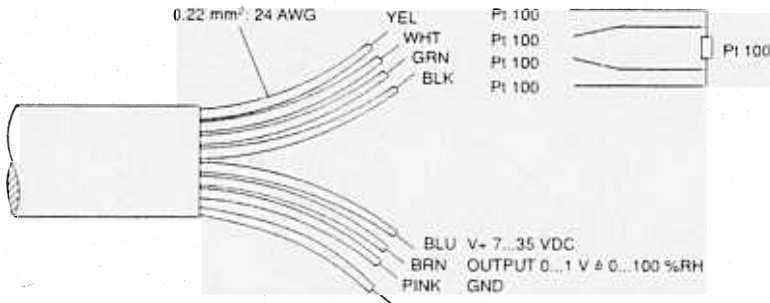
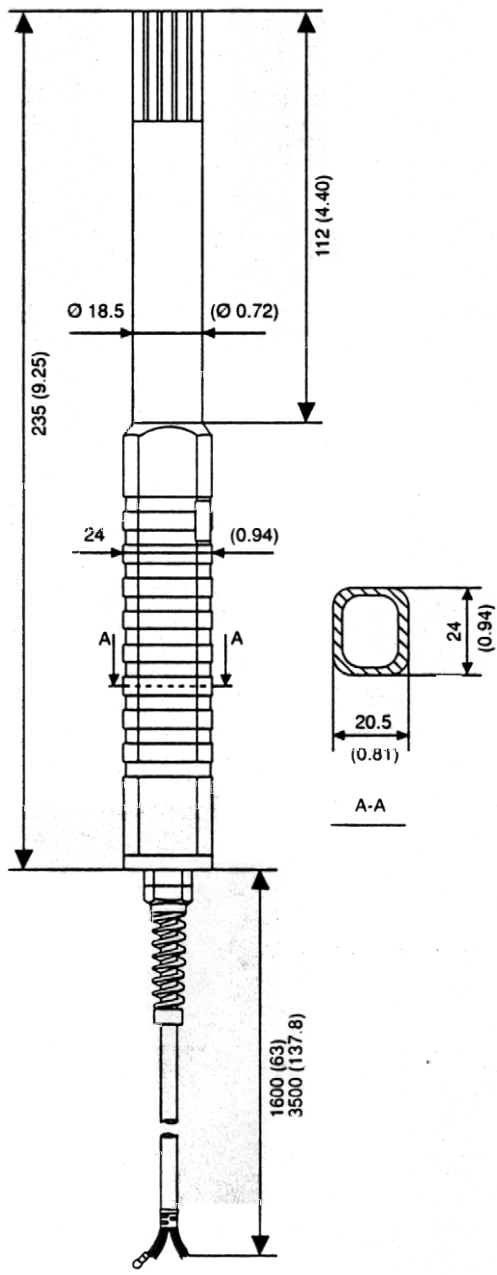

Fig. 1 Dimensions, HMP 35A & HMP 35D
Fig. 1 Dimensions, HMP 35A & HMP 35D
Bild 1 Maße, HMP 35A & HMP 35D
Kuva 1 Mitat, HMP 35A & HMP 35D



Cable length	HMP 35A	HMP 35D
Longueur du câble	1600 mm	3500 mm
Länge des Kabels		
Kaapelin pituus		

HMP 35D

- Fig. 4** Electrical connections
Fig. 4 Connexions électriques
Bild 4 Elektrische Anschlüsse
Kuva 4 Sähköiset liittännät

