

**TD OPERATING SYSTEM ADDENDUM FOR CR510, CR10X,
AND CR23X MANUALS**

REVISION: 1/03

COPYRIGHT © 2002-2003 CAMPBELL SCIENTIFIC, INC.

TD and PakBus Operating System Addendum for CR510, CR10X, and CR23X Manuals

AD1 Major Differences

Table Data (TD) operating systems have two major differences from the standard operating systems: First - the namesake - in the way data are stored internally and second, in the options available for transferring that data to external devices. The standard operating systems support both on site external storage (i.e., storage modules) that may be manually retrieved and telecommunications. The TD operating systems have more advanced telecommunication and networking capabilities but do not support storage modules. There are two versions of the TD operating system: TD and PakBus. The PakBus operating system includes the PakBus communications protocol that allows some additional communications options (Section 12); other features are the same as the TD operating system.

The datalogger hardware and direct measurement capabilities are the same in either case.

Feature	Table Data OS	Standard OS
Internal Data Storage	Multiple Data Tables, at least one Table for each output interval.	One or two Final Storage Areas. Data Arrays output at different intervals may share the same area and are identified by ID.
Term for a set of values output together	Record (a row of the table)	Array
Term for individual values within the array or record	Field (a column of the table)	Element
Number of elements or fields in an array or record	A fixed number, determined by the program	Generally fixed but conditional elements possible. Determined by program
Conditional Output	Yes	Yes
TimeStamps	Automatic	Optional
At Site / Manual Data Transfer	No	Yes
Storage Module Support	No	Yes
Instruction 96 – Serial Output	No	Yes
Instruction 98 – Send Character	No	Yes
Telecommunications	Commands protocol with error checking on all commands and responses. Feedback to confirm commands have been accepted.	Simple commands with error checking on data sent from datalogger to computer
Error Checking for data	Yes	Yes
Confirmation for Commands	Yes	No
Data Advise – data automatically sent (speeds multi-hop RF)	Yes	No
PakBus packet switching.	Yes – in PakBus	No
Supports Wireless Sensor	Yes – in PakBus	No
Support for Satellite Transmitters	No	Yes
Analog Measurements	No Difference	No Difference
Pulse Measurements	No Difference	No Difference

AD2 Overview of Data Storage Tables

Within a data table, data is organized in records and fields. Each row in a table represents a record and each column represents a field. To understand the concept of tables it may be helpful to consider an example. A CR10-TD is to be used to monitor 3 thermocouples (TC). Each hour a temperature for each of the three TC is to be stored. The table has 4 fields : "DATE_TIME TEMP1 TEMP2 TEMP3". Each hour a new "record" would be added. The "hourly" table would then be organized as follows:

<u>DATE</u>	<u>TIME</u>	<u>TEMP1</u>	<u>TEMP2</u>	<u>TEMP3</u>
01/27/91	10:00:00	23.5	24.6	28.2
01/27/91	11:00:00	24.2	22.4	23.4

Only the hourly data is stored in the hourly table, Each output interval has its own table. Data tables can also be "event driven" rather than interval driven, that is a new record is stored when a specified event occurs rather than based on time. Each table is completely independent of any other tables and all records in a given table have the same number of fields.

The TD operating system supports naming of tables and fields, so any data value can be referenced by the table and field names. For example, the temperature data for the first thermocouple is referenced as "HOURLY.TEMP1". Computer software also allows the station to be named. When multiple dataloggers are in use, this can be used to reference specific data in the network. If, in the previous example, the CR10T site was named DALLAS, the first thermocouple's data values would be referenced by "DALLAS.HOURLY.TEMP1".

AD3 Converting an existing program to Table Based OS

This section is intended for those familiar with programming an Array based datalogger.

AD3.1 Programming changes

- Remove all Record Real Time instructions (Instruction 77).
- Remove all Serial Data Output and Serial Print instructions (Instructions 96 and 98).
- Remove all Initiate Telecommunication (callback) instructions (Instruction 97).
- Check all instructions which set the Output Flag (Flag 0). These should be replaced with the Data Table Instruction (Instruction 84). If the Set Active Storage Area instruction (Instruction 80) is used, it should be removed as Instruction 84 provides this functionality.
- Check all If Time Instructions (Instruction 92) as the units may change from minutes to seconds. Any instruction 92 that sets the output flag (Flag 0) is replaced by Instruction 84.
- Check the Move Time To Input Location Instruction (Instruction 18) as some parameters have changed.

- Check the Maximum and Minimum Instructions (Instructions 73 and 74) as there is only one option to store time with the value.
- Edit Input Location labels removing all spaces and special characters. Only letters, numbers, and the “_” characters are allowed. Labels should start with a letter.
- Add labels for the Final Storage values. Use the same character as are allowed for Input Location labels. See Section 2.1

AD3.2 Making the Changes with Edlog

Programs for Array based logger can be converted to Table Based using EDLOG for most of the editing by doing the following:

1. Make a copy of the original program with the name you want the new program to have: Load the original into Edlog and “Save As” the new name.
2. Remove or comment out all Instructions 77, 96, 97, and 98. (first three points in AD3.1, these instructions are not in the Table OS)
3. Save the edited program and close it in Edlog.
4. Edit the CSI file with a text editor (e.g., “Notepad” - Edlog will not allow you to make and save this change) and add -TD to the datalogger type on the first line, for example, change:
;{CR10X}
to:
;{CR10X-TD}.
Save the CSI file and close the editor.
5. Open the file with Edlog. Edlog should now recognize that the program is for a table data OS.
6. Add Instructions 84 where necessary and make the other necessary changes.

AD4 Summary of Differences from the Datalogger Manual:

Section	Differences
Overview	Figure OV2.1-2: See Figure 1.5-1 in Addendum. Table OV3.2-1: See Table OV4.1-1 in TD Addendum. OV4, OV5, OV6 : See TD Addendum.
Section 1	Section 1.5 A Mode is replaced by addendum – the TD loggers allocate memory differently. Section 1.8 - *D Mode is replaced by TD Addendum – TD loggers do not support storing multiple programs or Storage Modules. PakBus Settings are added to the *D Mode.
Section 2	Replaced entirely by TD Addendum.
Section 3	Section 3.7.1 does not apply to the TD operating system which does not use Output Flag 0 . Table 3.8-1 Valid Flag Commands are 11 – 19 to set high and 21- 29 to set Low. Because the TD operating system does not use Flag 0, Commands 10 and 20 are not valid with the TD operating system. Table 3.10-1 TD Addendum. has a corrected version
Section 4	Does not apply: The TD operating system does not support External Storage Peripherals.
Section 5	Does not apply: The communications commands and protocol of the TD operating system is different than that of the standard operating systems. Campbell Scientific provides software for communications; a description of the protocol is beyond the scope of this addendum.
Section 6	Many of the peripherals discussed in section 6 are not supported by the TD operating system.
Section 7	No Change
Section 8	Replaced entirely by TD Addendum.
Section 9	Instruction 18 has some differences in the time options, see addendum.
Section 10	No Change
Section 11	Instructions 73 and 74 have only one option for storing the time of max or min (time is output as a quoted string). Instruction 80 – Set Active Storage Area, is not in the TD operating system. Its functions are included in Instruction 84 – Data Table. Instruction 84 – Data Table, sets the conditions and destination for output data. This instruction is only in the TD operating system (see TD Addendum..)

TABLE DATA ADDENDUM

<p>Section 12</p>	<p>The TD operating system does not use the output Flag 0. Commands dealing with it are not valid.</p> <p>Instruction 92 – There is no option for minutes, time is in seconds only.</p> <p>Instructions Not In TD OS: Instruction 96 – Serial Output Instruction 98 – Send Character Instruction 111 – Load Program from Flash</p> <p>New Instructions for PakBus:</p> <p>Instruction 190 – Send or Get Input Locations Instruction 191 – One way Final Storage Data Transfer Instruction 192 – PakBus Message Instruction 193 – Wireless Network Master Control Instruction 194 – Time Until Transmit Instruction 195 – Set Clock from Address Instruction 196 – Wireless Remote Instruction 197 – Force Route Through Address</p>
<p>Section 13</p>	<p>No Change</p>
<p>Section 14</p>	<p>No Change</p>

TABLE DATA ADDENDUM

MEASUREMENT AND CONTROL MODULE OVERVIEW

While this section of the addendum references the CR10X, everything but the measurement instructions in the example programs applies to the other dataloggers as well.

Table OV3.2-1 in the CR10X Manual is incorrect for the TD operating system. See Table OV4.1-1 below.

The following sections OV4, OV5, and OV6 replace those in the CR10X Manual.

OV4. PROGRAMMING THE CR10X

A program is created by entering it directly into the datalogger or into a computer using the LOGGNET program EDLOG. This manual describes direct interaction with the CR10X. Work through the direct programming examples in this overview before using EDLOG and you will know the basics of CR10X operation as well as an appreciation for the help provided by the software. Section OV4.5 describes options for loading the program into the CR10X.

OV4.1 FUNCTIONAL MODES

CR10X/User interaction is broken into different functional MODES (e.g., programming the measurements and output, setting time, etc.). The modes are referred to as Star (*) Modes since they are accessed by first keying *, then the mode number or letter. Table OV4.1-1 lists the CR10X Modes.

OV4.2 KEY DEFINITION

Keys and key sequences have specific functions when using the CR10KD keyboard or a computer in the remote keyboard state (Section 5). Table OV4-2 lists these functions. In some cases, the exact action of a key depends on the mode the CR10X is in and is described with the mode in the manual.

When using a computer/terminal to communicate with the CR10X (Telecommunications) there are some keys available in addition to those found on the CR10KD. Table OV4.2-2 lists these keys.

TABLE OV4.1-1. * Mode Summary

<u>Key</u>	<u>Mode</u>
*0	LOG data and indicate active Tables
*1	Program Table 1
*2	Program Table 2
*3	Program Table 3, subroutines only
*5	Display/set real time clock
*6	Display/alter Input Storage data, toggle flags and ports
*7	Display Data Storage Table data
*9	Display Data Storage Table sizes
*A	Memory allocation/reset
*B	Signature/status
*C	Security

TABLE OV4.2-1. Key Description/Editing Functions

<u>Key</u>	<u>Action</u>
0-9	Key numeric entries into display
*	Enter Mode (followed by Mode Number)
A	Enter/Advance
B	Back up
C	Change the sign of a number or index an input location to loop counter
D	Enter the decimal point
#	Clear the rightmost digit keyed into the display
#A	Advance to next instruction in program table (*1, *2, *3)
#B	Back up to previous instruction in program table.
#D	Delete entire instruction

TD ADDENDUM—OVERVIEW

TABLE OV4.2-2. Additional Keys Allowed in Telecommunications

<u>Key</u>	<u>Action</u>
-	Change Sign, Index (same as C)
CR	Enter/advance (same as A)

OV4.3 PROGRAMMING SEQUENCE

In routine applications, the CR10X measures sensor output signals, processes the measurements over some time interval and stores the processed results. A generalized programming sequence is:

1. Enter the execution interval. In most cases, the execution interval is determined by the desired sensor scan rate.
2. Enter the Input/Output instructions required to measure the sensors.
3. If processing in addition to that provided by the Output Processing Instructions (step 5) is required, enter the appropriate Processing Instructions.
4. Enter the Data Table Instruction 84 to test the output condition and output when the condition is met. For example, use

Instruction 84 to output based on time.

Instruction 84 to output every execution interval.

Instruction 84 to output based on a Program Flag.

This instruction must precede the Output Processing Instructions which store data in a Data Storage Table. Instructions are described in Sections 9 through 12.
5. Enter the Output Processing Instructions to store processed data in the Data Storage Table. The order in which data are stored is determined by the order of the Output Processing Instructions in the table.
6. Repeat steps 4 through 6 for additional outputs on different intervals or conditions.

NOTE: The program must be executed for output to occur. Therefore, the interval specified with the Data Table Instruction is set must be evenly divisible by the execution interval. For example, with a 2 minute execution interval and a 5 minute output interval, the program will only be executed on the even multiples of the 5 minute intervals, not on the odd. Data will be output every 10 minutes instead of every 5 minutes.

Execution intervals are synchronized with midnight. Output intervals set with Instruction 84 are synchronized with real time starting at midnight, January 1, 1990.

OV4.4 INSTRUCTION FORMAT

Instructions are identified by an instruction number. Each instruction has a number of parameters that give the CR10X the information it needs to execute the instruction.

The CR10X Prompt Sheet has the instruction numbers in red, with the parameters briefly listed in columns following the description. Some parameters are footnoted with further description under the "Instruction Option Codes" heading.

For example, Instruction 73 stores the maximum value that occurred in an Input Storage location over the output interval. The instruction has three parameters (1) REPetitionS, the number of sequential Input Storage locations on which to find maxima, (2) TIME, an option of storing the time of occurrence with the maximum value, and (3) LOC the first Input Storage location operated on by the Maximum Instruction. The codes for the TIME parameter are listed in the "Instruction Option Codes".

The repetitions parameter specifies how many times an instruction's function is to be repeated. For example, four 107 thermistor probes may be measured with a single Instruction 11, Temp-107, with four repetitions. Parameter 2 specifies the input channel of the first thermistor (the probes must be connected to sequential channels). Parameter 4 specifies the Input Storage location in which to store measurements from the first thermistor. If location 5 were used and the first probe was on channel 1, the temperature of the thermistor on channel 1 would be stored in input

location 5, the temperature from channel 2 in input location 6, etc.

Detailed descriptions of the instructions are given in Sections 9-12. Entering an instruction into a program table is described in OV5.

OV4.5 ENTERING A PROGRAM

Programs are entered into the CR10X in one of two ways:

1. Keyed in using the CR10X keyboard
2. Stored on disk/seat from computer

A program is created by keying it directly into the datalogger as described in Section OV5, or on a PC using EDLOG.

EDLOG is used to develop programs for Campbell Scientific CR10X dataloggers. EDLOG is a prompting editor for writing and documenting programs for Campbell Scientific CR10X dataloggers. Program files developed with EDLOG can be downloaded directly to the CR10X using NetAdmin. NetAdmin supports communication via direct wire, telephone, or Radio Frequency (RF).

OV5. PROGRAMMING EXAMPLES

We will start with a simple programming example. There is a brief explanation of each step to help you follow the logic. When the example uses an instruction, find it on the Prompt Sheet and follow through the

description of the parameters. Using the Prompt Sheet while going through these examples will help you become familiar with its format. Sections 9-12 have more detailed descriptions of the instructions.

With the Wiring Panel connected to the CR10X, hook up the power leads as described in Section OV1.2. Next, connect the CR10X to either a CR10KD Keyboard/Display or the computer (Section OV3). The programming steps in the following examples use the keystrokes possible on the keyboard/display. With a terminal, some responses will be slightly different.

If the CR10KD is connected to the CR10X when it is powered up, the display will show:

<u>Display</u>	<u>Explanation</u>
HELLO	On power-up, the CR10X displays "HELLO" while it checks the memory (this display occurs only with the CR10KD).

after a few seconds delay

:96	The size of the machine's total memory (RAM plus 32 K of ROM), in this case 96K
-----	---------------------------------------------------------------------------------

OV5.1 SAMPLE PROGRAM 1

In this example the CR10X is programmed to read its own internal temperature (using a built in thermistor) every 5 seconds and to send the results to Final Storage.

<u>Key</u>	<u>Display</u>	<u>Explanation</u>
*	00:00	Enter mode.
1	01:00	Enter Program Table 1.
A	01:0.0000	Advance to execution interval (In seconds)
5	01:5	Key in an execution interval of 5 seconds.
A	01:P00	Enter the 5 second execution interval and advance to the first program instruction location.
17	01:P17	Key in Instruction 17 which directs the CR10X to measure the internal temperature in degrees C. This is an Input/Output Instruction.
A	01:0000	Enter Instruction 17 and advance to the first parameter.
1	01:1	The input location to store the measurement, location 1.
A	02:P00	Enter the location # and advance to the second program instruction.

The CR10X is now programmed to read the internal temperature every 5 seconds and place the reading in Input Storage Location 1. The program can be compiled and the temperature displayed.

TD ADDENDUM—OVERVIEW

<u>Key</u>	<u>(ID:Data)</u>	<u>Explanation</u>
*0	LOG 1	Exit Table 1, enter *0 Mode, compile table and begin logging.
*6	06:0000	Enter *6 Mode (to view Input Storage).
A	01:21.234	Advance to first storage location. Panel temperature is 21.234°C (the display will show the actual temperature).

Wait a few seconds:

	01:21.423	The CR10X has read the sensor and stored the result again. The internal temp is now 21.423°C. The value is updated every 5 seconds when the table is executed. At this point the CR10X is measuring the temperature every 5 seconds and sending the value to Input Storage. No data are being saved. The next step is to have the CR10X send each reading to Final Storage.
*1	01:00	Exit *6 Mode. Enter program table 1.
2A	02:P00	Advance to 2nd instruction location (this is where we left off).
84	02:P84	This is the Data Table Instruction.
A	01:0.0000	Enter 84 and advance to the first parameter (which is the time into the interval).
0	01:0	This parameter determines when in the output internal data is stored. 0 stores data on the even interval.
A	02:0.000	Enter 0 and advance to the second parameter.
0	02:0	This parameter specifies the output interval. 0 stores data each execution.
A	03:0.0000	Enter 0 and advance to third parameter.
1000	03:1000.00	This parameter specifies how many records to store in the table before overwriting the oldest. For this example, keep 1000 records.
A	03:P00	Enter 1000 and advance to the third program instruction.
70	03:P70	The SAMPLE instruction. It directs the CR10X to take a reading from an Input Storage location and send it to Final Storage (an Output Processing Instruction).
A	01:0000	Enter 70 and advance to the first parameter (repetitions).
1	01:1	There is only one input location to sample; repetitions = 1.
A	02:0000	Enter 1 and advance to second parameter (Input Storage location to sample).
1	02:1	Input Storage Location 1, where the temperature is stored.
A	04:P00	Enter 1 and advance to fourth program instruction.
*	00:00	Exit Table 1.
0	LOG 1	Enter *0 Mode, compile program, log data.

OV5.2 SAMPLE PROGRAM 2

This second example is more representative of a real-life data collection situation. Once again the internal temperature is measured, but it is used as a reference temperature for the differential voltage measurement of a type T (copper-constantan) thermocouple; the CR10X should have arrived with a short type T thermocouple connected to differential channel 5.

When using a type T thermocouple, the copper lead (blue) is connected to the high input of the differential channel, and the constantan lead (red) is connected to the low input.

A thermocouple produces a voltage that is proportional to the difference in temperature between the measurement and the reference junctions.

To make a thermocouple (TC) temperature measurement, the temperature of the reference junction (in this example, the approximate panel temperature) must be measured. The CR10X takes the reference temperature, converts it to the equivalent TC voltage relative to 0°C, adds the measured TC voltage, and converts the sum to temperature through a polynomial fit to the TC output curve (Section 13.4).

The internal temperature of the CR10X is not a suitable reference temperature for precision thermocouple measurements. It is used here for the purpose of training only. To make thermocouple measurements with the CR10X, purchase the Campbell Scientific Thermocouple Reference, Model CR10XCR (Section 13.4) and make the reference temperature measurement with Instruction 11.

Instruction 14 directs the CR10X to make a differential TC temperature measurement. The first parameter in Instruction 14 is the number of times to repeat the measurement. Enter 1, because in this example there is only one thermocouple. If there were more than 1 TC, they could be wired to sequential channels, and the number of thermocouples entered for repetitions. The CR10X would automatically advance through the channels sequentially and measure all of the thermocouples.

Parameter 2 is the voltage range to use when making the measurement. The output of a type T thermocouple is approximately 40 microvolts

per degree C difference in temperature between the two junctions. The ± 2.5 mV scale will provide a range of $\pm 2500/40 = \pm 62.5^\circ\text{C}$ (i.e., this scale will not overrange as long as the measuring junction is within 62.5°C of the panel temperature). The resolution of the ± 2.5 mV range is $0.33 \mu\text{V}$ or 0.008°C .

Parameter 3 is the analog input channel on which to make the first, and in this case only, measurement. Parameter 4 is the code for the type of thermocouple used. This information is located on the Prompt Sheet or in the description of Instruction 14 in Section 9. The code for a type T (copper-constantan) thermocouple is 1.

Parameter 5 is the Input Storage location in which the reference temperature is stored. Parameter 6 is the Input Storage location in which to store the measurement (or the first measurement; e.g., if there are 5 repetitions and the first measurement is stored in location 3, the final measurement will be stored in location 7). Parameters 7 and 8 are the multiplier and offset. A multiplier of 1 and an offset of 0 outputs the reading in degrees C. A multiplier of 1.8 and an offset of 32 converts the reading to degrees F.

In this example, the sensor is measured once a minute, and the average temperature is output every hour. Once a day the maximum and minimum temperatures and the times they occur will be output.

The first example described program entry one keystroke at a time. This example does not show the "A" key. Remember, "A" is used to enter and/or advance (i.e., between each line in the example below). This format is similar to the format used in EDLOG.

It's a good idea to have both the manual and the Prompt Sheet handy when going through this example. You can find the program instructions and parameters on the Prompt Sheet and can read their complete definitions in the manual.

To obtain daily output, the Data Table instruction is followed by the Output Instructions to store the daily maximum and minimum temperatures and the time each occurs.

TD ADDENDUM—OVERVIEW

SAMPLE PROGRAM 2

<u>Instruction # (Loc:Entry)</u>	<u>Parameter (Par#:Entry)</u>	<u>Description</u>
*1		Enter Program Table 1
01:60		60 second (1 minute) execution interval
Key "#D" repeatedly until is displayed	01:P00	Erase previous Program before continuing.
01:P17	01:1	Measure internal temperature Store temp in Location 1
02:P14	01:1 02:1 03:5 04:1 05:1 06:2 07:1 08:0	Measure thermocouple temperature (differential) 1 repetition Range code (2.5 mV, slow) Input channel of TC TC type: copper-constantan Reference temp is stored in Location 1 Store TC temp in Location 2 Multiplier of 1 No offset
03:P84	01:0 02:3600 03: 0	Data Table Instruction 0 seconds into the interval 3600 second (60 min.) interval Automatically allocate # of records

The CR10X is programmed to measure the thermocouple temperature every sixty seconds. The CR10X automatically allocates the number of records. Time information is automatically stored. Next the output instruction for the average is added.

<u>Instruction # (Loc.:Entry)</u>	<u>Parameter (Par.#:Entry)</u>	<u>Description</u>
04:P71	01:1 02:2	Average instruction One repetition Location 2 - source of TC temps. to be averaged
05:P84	01:0 02:86400 03:0	Data Table Instruction 0 seconds into the interval 86400 second interval (24 hrs.) Automatically allocate # of records
06: P73	01:1 02:1 03:2	Maximize instruction One repetition Output the time of the daily maximum Data source is Input Storage Location 2.
07: P74	01:1 02:1 03:2	Minimize instruction One repetition Output the time of the daily minimum Data source is Input Storage Location 2.

The program to make the measurements and send the desired data to Final Storage has been entered. The program is complete. The clock must now be set so that the date and time tags are correct. (Here the example reverts back to the key by key format.)

<u>Key</u>	<u>Display</u>	<u>Explanation</u>
*5	00:21:32	Enter *5 Mode. Clock running but not set correctly.
A	05:01.01	Advance to month-day (MMDD).
1004	05:1004	Key in MMDD (Oct 4 in this example).
A	05:1990	Enter and advance to location for year.
1994	05:1994	Key in year.
A	05:00:21	Enter and advance to location for hours and minutes (24 hr. time).
1324	05:1324	Key in hrs.:min. (1:24 PM in this example).
A	05:27.250	Key in seconds
30	05:30	
A	13:24:30	Clock set and running. Changes made when A was pressed.
*0	LOG 1	Exit *5, compile Table 1, commence logging data.

OV5.3 EDITING AN EXISTING PROGRAM

When editing an existing program in the CR10X, entering a new instruction inserts the instruction; entering a new parameter replaces the previous value.

To insert an instruction, enter the program table and advance to the position where the instruction is to be inserted (i.e., P in the data portion of the display) key in the instruction number, and then key A. The new instruction will be inserted at that point in the table, advance through and enter the parameters. The instruction that was at that point and all instructions following it will be pushed down to follow the inserted instruction.

An instruction is deleted by advancing to the instruction number (P in display) and keying #D (Table 4.2-1).

To change the value entered for a parameter, advance to the parameter and key in the correct value then press A. Note that the new value is not entered until A is keyed.

OV6. DATA RETRIEVAL OPTIONS

Data is retrieved over some form of telecommunications link, whether it be RF (radio), telephone, short haul modem, coaxial cable (multidrop) , or direct link. The table data operating system does not support on-line output to peripheral storage devices (see Figure OV 6.1-1).

The retrieval of data does NOT erase those data from the Data Storage Tables in Final Storage. The data remains in the table ring memory until:

The are written over by new records of data. (Section 2.1)

Input Storage memory is reallocated (Section 1.5)

The datalogger program is changed and compiled.

Power to the datalogger is turned off.

TD ADDENDUM—OVERVIEW

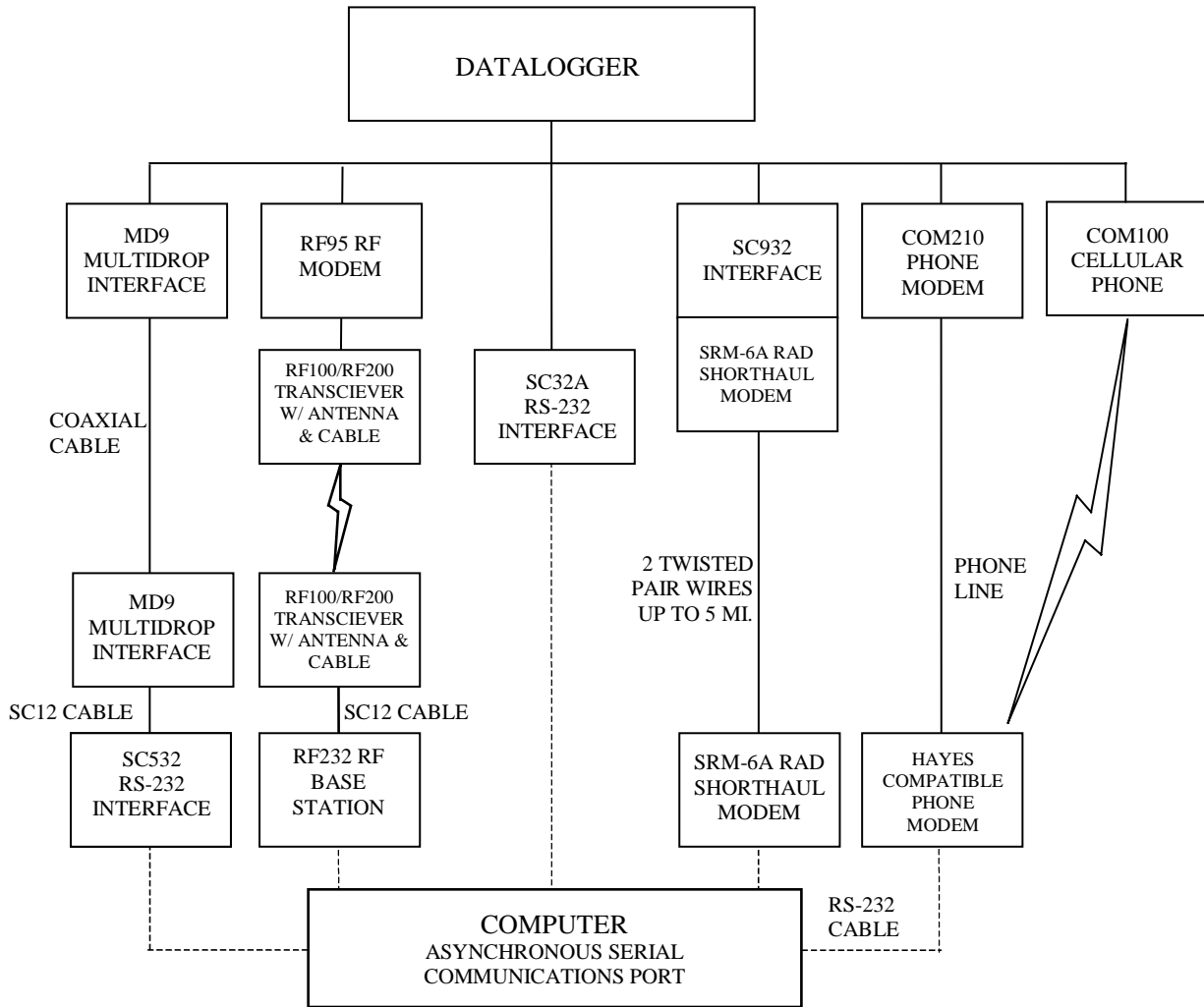

- NOTES:**
1. ADDITIONAL METHODS OF DATA RETRIEVAL ARE:
 - A. SATELLITE TRANSMISSION
 - B. DIRECT DUMP TO PRINTER
 - C. VOICE PHONE MODEM TO VOICE PHONE OR PC WITH HAYES COMPATIBLE PHONE MODEM
 2. THE DSP4 HEADS UP DISPLAY ALLOWS THE USER TO VIEW DATA IN INPUT STORAGE. ALSO BUFFERS FINAL STORAGE DATA AND WRITES IT TO CASSETTE TAPE, PRINTER OR STORAGE MODULE.
 3. ALL CAMPBELL SCIENTIFIC RS-232 INTERFACES HAVE A FEMALE 25 PIN RS-232 CONNECTOR.

FIGURE OV6.1-1. Data Retrieval Hardware Options

SECTION 1. FUNCTIONAL MODES

Sections 1.5 and 1.8 are replaced by the following sections.

1.5 MEMORY ALLOCATION - *A

1.5.1 INTERNAL MEMORY

When powered up with the keyboard display attached, the CR10KD displays HELLO while performing a self check. The total system memory is then displayed in K bytes. The size of memory can be displayed in the *B mode.

Input Storage is used to store the results of Input/Output and Processing Instructions. The values stored in input locations may be displayed using the *6 Mode (Section 1.3).

Final Storage holds stored data for a permanent record. Output Instructions store data in Final Storage Data Tables. The data in Final Storage can be monitored using the *7 Mode (Section 2.3).

Intermediate Storage is a scratch pad for Output Processing Instructions. It is used to store the results of intermediate calculations necessary for averages, standard deviations, histograms, etc. Intermediate Storage is not accessible by the user.

Each Input or Intermediate Storage location requires 4 bytes of memory. Each Final Storage location requires 2 bytes of memory. Low resolution data points require 1 Final Storage location and high resolution data points require 2. Section 2 describes Final Storage and data retrieval in detail.

Figure 1.5-1 lists the basic memory functions and the amount of memory allotted to them.

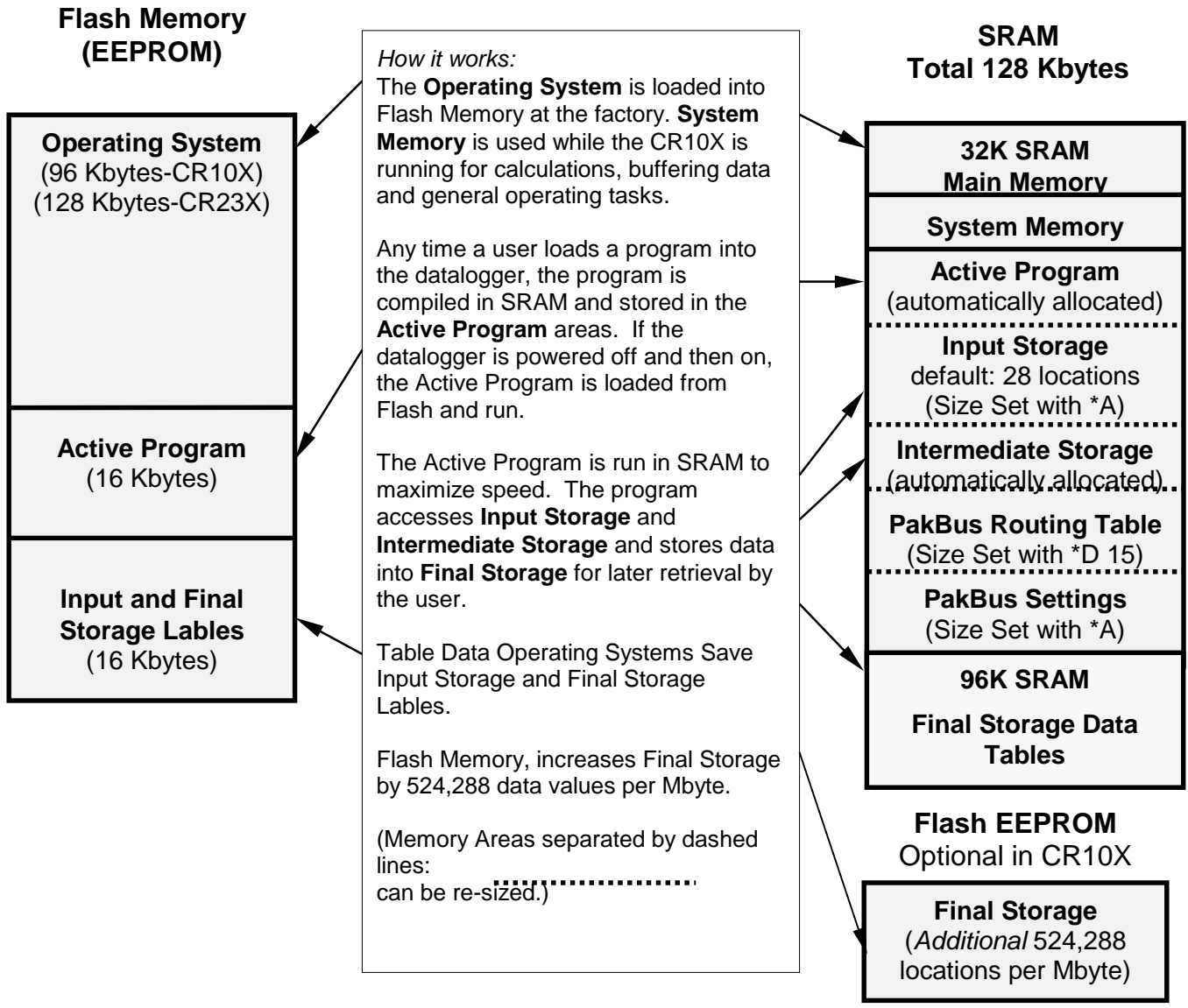

FIGURE 1.5-1. Datalogger Memory

1.5.2 *A MODE

The *A Mode is used to 1) check the size of Input Storage, Intermediate Storage, Final Storage, Program Memory; PakBus and user Settings memory 2) check the number of bytes remaining in Flash Program memory; Main Memory, and Label Memory 3) change the memory allotted to Input Locations and Settings; and 5) to completely reset the datalogger.

When *A is entered, the first number displayed is the number of memory locations allocated to

Input Storage. The "A" key is used to advance through the next 6 windows. Table 1.5-2 describes what the values in the *A Mode represent.

The sizes of Input Storage and Settings Memory may be altered by keying in the desired value and entering it by keying "A".

TABLE 1.5-2. Description of *A Mode Data

<u>Keyboard Entry</u>	<u>Display ID: Data</u>	<u>Description of Data</u>
* A	01: XXXX	Input Storage Locations (minimum of 28, maximum of 6655, but the usable maximum is less than this because intermediate and program storage require some of this memory). This value can be changed by keying in the desired number.
A	02: XXXX	Intermediate Storage Locations (maximum limited by available memory and constraints on Input and Final Storage). The CR10X-TD will assign the exact number needed for the active program. The CR10X-TD erases all data whenever the program is changed and compiled.
A	03: XXXXX	Final Storage Locations (minimum of 0, maximum limited by available memory). Changing this number automatically reallocates Final Storage Area 1.
A	04: XXXXX	Bytes allocated for user program. The CR10X-TD will assign the exact number needed. The CR10X-TD erases all data whenever the program is changed and compiled. Key in 98765 to completely reset datalogger.
A	05:	Bytes free in Flash Memory for active program. The user cannot change this window. It is a function of window 5 and the program.
A	06:	PakBus and user Settings memory
A	07:	Main Memory Free
A	06:	Label Bytes Free

The maximum size of of Final Storage is determined by the memory installed (Table 1.5-1). The size of Final Storage and the rate at which data are stored determines how long it will take for Final Storage to fill, at which point new data will write over old.

Twenty-eight is the minimum number of Input locations allowed. Intermediate Storage and Final Storage are erased when the number of Input locations is changed. This feature may be used to clear memory without altering programming. The number of locations does not actually need to be changed; the same value can be keyed in and entered.

Intermediate Storage and Program Memory are automatically allocated. All data are erased any time the program is changed and compiled. If there is not enough memory available in the 32K Main Memory for the Intermediate Storage required by the current program, the "E:04" ERROR CODE will be displayed in the *0, *6, and *B Modes.

After repartitioning memory, the program must be recompiled. Compiling erases Intermediate Storage. Compiling with *0 erases Input Storage; compiling with *6 leaves Input Storage unaltered (If its size was unchanged).

ENTERING 98765 in the program memory window 6 COMPLETELY RESETS THE CR10X. All memory is erased including the program and memory is checked. Memory allocation returns to the default. The reset operation requires approximately 1 minute for a CR10X, 5 minutes for a CR10X-1M, and 10 minutes for a CR10X-2M. Please be patient while the reset takes place; if the CR10X is turned off in the middle of a reset, it will perform the reset the next time it is powered up.

1.6 MEMORY TESTING AND SYSTEM STATUS - *B

No changes from standard operating system, see datalogger manual.

1.7 *C MODE -- SECURITY

No changes from standard operating system, see datalogger manual.

1.8 *D MODE – TRANSFER PROGRAMS, GENERAL SETTINGS

The *D Mode is used to transfer datalogger programs between a datalogger and a computer, to erase a program, to set the degree

TD ADDENDUM — SECTION 1. FUNCTIONAL MODES

to which memory is cleared on powerup, to set the PakBus ID, and to set communication to full or half duplex.

CSI datalogger support software makes use of the *D Mode to upload and download programs from a computer. Appendix C gives some additional information on Commands 1 and 2 that are used for these operations.

When "*D" is keyed in, the CR10X will display "13:00". A command (Table 1.8-1) is entered by keying the command number and "A".

TABLE 1.8-1. *D Mode Commands

<u>Command</u>	<u>Description</u>
1	Send (Print) ASCII Program
2	Load ASCII Program, *0 Compile
2--	Load ASCII Program, *6 Compile
3	# Rings Before Answering Phone
7	Erase Current Program
10	Set Powerup Options
12	Set Initial Baud
15	PakBus Address/Routing Table
16	Memory for General Purpose File
17	PakBus Routing Table
18	PakBus Beacon Interval
19	PakBus Neighbor List

If the CR10X program has not been compiled when the command to save a program is entered, it will be compiled before the program is saved. When a program is loaded, it is immediately compiled and run. When a command is complete, "13:0000" is displayed; *D must be entered again before another command can be given.

TABLE 1.8-2. Program Load Error Codes

E 94	Program Storage Area full
E 95	Program does not exist in flash
E 96	Storage Module not connected or wrong address
E 97	Data not encountered within 30 sec.
E 98	Uncorrectable errors detected
E 99	Wrong type of file or Editor Error

1.8.1 ERASING CURRENT PROGRAM

The 7 command may be used to delete the current program as show in Table 1.8-3.

TABLE 1.8-3 Deleting Current Datalogger Program

Key entry	Display
*D	13:00
7A	07:00
You may now enter:	
0A	Erase active program (i.e., load a blank program; memory allocation and Final Storage are reset).

1.8.2 PROGRAM TRANSFER WITH STORAGE MODULE

Not supported in Table Data Operating Systems.

1.8.3 FULL/HALF DUPLEX

Not supported in Table Data Operating Systems.

1.8.4 SET DATALOGGER ID

Command 8 not supported in Table Data Operating Systems.

1.8.5 SETTING POWERUP OPTIONS

Setting options for the Program on Powerup allows the user to specify what information to retain from when the datalogger was last on. This allows Flag/Port status, the User Timer, and the Input/Intermediate Storage to be cleared or not cleared.

Table 1.8-8. Setting Powerup Options

Key entry	Display
*D	13:00
10A	10:0X

Where X is the powerup option currently selected. You may now change the option:

0A	Clears input locations, ports, flags, user timer, and intermediate storage locations.
1A	Clears intermediate storage only (leaves Input Storage, Flags/Ports, and User Timer as is).
2A	Doesn't clear anything.

1.8.6 SET INITIAL BAUD

Table 1.8-10 shows the option codes available for setting the initial baud rate. Setting the initial baud rate forces the CR10X to try the selected baud rate first when connecting with a device.

<u>Key Entry</u>	<u>Display</u>	<u>Comments</u>
*D	13:00	Enter Command
12A	12:00	Connect Baud Rate Enter Baud Rate Code X (Table 1.8-11).

X = 0	300 Baud
X = 1	1200 Baud
X = 2	9600 Baud
X = 3	76.8 K Baud

1.8.7 SET PROGRAM COMPILE OPTION

Command 13 is not supported in Table Data operating systems.

1.8.8 SET PAKBUS ADDRESS

*D 15 allows the user to set the PakBus Address of the datalogger and to set the maximum size for its routing table.

TABLE 1.8-11. PakBus Address and Routing Table

<u>Key Entry</u>	<u>Display</u>	<u>Comments</u>
*D	13:00	Enter Command
15A	15:xxxx	PakBus Address , Enter zero if the datalogger is not to be used as a PakBus device (1..4094 is legal, the default is 1)
A	01:xxxx	If the datalogger is to be used a a router, enter the maximum number of nodes (PakBus Addresses) to allocate space for in the pakbus network. 0 = leafnode, <>0 = router
A	02:xxxx	Enter the maximum number of neighbors in the pakbus network to allocate space for. This parameter is used only if datalogger is used as a router (01: is non-zero).
A	03:xxxx	Enter maximum number of routers in the pakbus network to allocate space for. This parameter is used only if datalogger is used as a router (01: is non-zero).
A	04:xxxx	Enter the PakBus address for a default router (1..4094, 0 for no default router). The default router is used for a message if the destination PakBus address is not in the routing table. A router discovering new routes will not explore beyond its own default router.

The memory for a routing table comes out of the pool for program, input locations, and intermediate storage.

The total number of bytes used for the routing table =

$$\begin{aligned} & \text{Nodes} \times 12 \\ & + \text{Neighbors} \times 8 \\ & + \text{Routers} \times 6 \\ & + (\text{Routers} \times (\text{Nodes} - \text{Routers}) + (\text{Routers} \\ & \times (\text{Routers} - 1))/2) \times 4 \end{aligned}$$

TD ADDENDUM — SECTION 1. FUNCTIONAL MODES

The *D15 entries are sent when the program is retrieved. They can also be set like other *D settings via the DLD file.

1.8.9 ALLOCATE MEMORY FOR GENERAL PURPOSE FILES

*D16:xx ;allocate xx 64K byte chunks of memory for general purpose files. The area comes out of final storage space. Files are stored in a circular buffer (ring memory) in this space.

1.8.10 VIEW ROUTING TABLE

*D17 allows viewing the current routing table information. This is view only.

TABLE 1.8-12. Values in Routing Table

Key Entry	Display	Comments
*D	13:00	Enter Command
17A		Enter the view routing table command
	01:xxxx	;pakbus address of destination node
	02:xxxx	;via neighbor with xxxx pakbus address
	03:xxxx	;a worst case response time metric (seconds)

(Repeats for next destination node.)

1.8.11 SET PAKBUS ROUTER BEACON INTERVAL

TABLE 1.8-13. Set Beacon interval

Key Entry	Display	Comments
*D	13:00	Enter Command
18A		Enter the beacon interval settings
A	01:xxxx	Enter the Interval (seconds) for SDC7
A	02:xxxx	Enter the Interval (seconds) for SDC8
A	03:xxxx	Enter the Interval (seconds) for CS I/O Pin Enabled, 9600 baud
A	04:xxxx	Enter the Interval (seconds) for RS232, 9600 baud (CR23X only)

1.8.12 PAKBUS NEIGHBOR FILTER

In some networks, sending beacons can be disruptive. Entering values in the *D19 mode disables the beacon. A PakBus datalogger with nonzero *D19 settings will not send beacons and will only respond to beacons from nodes with addresses in the neighbor list.

Instead of sending beacons, the datalogger will send "hello" messages to neighbors in the list to determine if it can communicate with them. Neighbors (or potential neighbors) should be nodes that communicate directly with the datalogger without going through a router.

Note that this list is not automatically cleared by compiling a new program. (It may be changed if the new program contains *D19 entries.) It can be edited by changing entries. Once 0 is entered for a neighbor address, all entries beyond the 0 entry are cleared.

TABLE 1.8-14. Set PakBus Neighbors

<u>Key Entry</u>	<u>Display</u>	<u>Comments</u>
*D	13:00	Enter Command
19A	19:00	Port (17- SDC7, 18 – SDC8, 02 – CSI/O, 02—CR23X RS232 port, 9600 baud
A	19:0000	Interval in seconds of the expected rate of communication. A neighbor is aged after 2.5 times this interval and the Hello attempt will be reinitiated.
A	01:xxxx	PakBus Address of neighbor Swath of neighbors with sequential addresses starting with above address.
A	01:xx	
A	02:xxxx	PakBus Address of neighbors Swath of neighbors with sequential addresses starting with above address.
A	02:xx	
... etc.		
A	nn:0000	Terminates the list.

1.9 *9 DATA TABLES SIZES.

The *9 Mode is used to view the sizes of the Data Storage Tables (section 2.1) created by the datalogger program (*1, *2, or *3). The *9 Mode will also display how long until any automatically allocated Data Storage Tables fill. All Data Storage Tables are in a ring configuration such that the oldest records are overwritten by new records once the table is full. The sizes are given as the number of records. A record can be thought of as a row of data where each field (i.e., column) is a data value associated with an Output Processing Instruction. The order and number of fields in a Data Table are determined by the Output Processing Instructions following the Data Table Instruction. The tables are numbered in the order the Data Table Instruction appear in the Program Tables, *1 first, *2 second, and *3 last.

TABLE 1.9-1. Description of * 9 Data

<u>Keyboard Entry</u>	<u>Display ID: Data</u>	<u>Description</u>
*9	09:xx	Number of tables/ Enter table number to jump to that table or 0 to see next parameter.
0A	00:x.xxxx	Days before any automatically allocated table fills.
A	01:xxxxx.	Number of records in table 01
A	02:xxxxx	Number of records in table 02
A	nn:xxxxx.	Number of records in table nn

TD ADDENDUM — SECTION 1. FUNCTIONAL MODES

THIS SECTION ENTIRELY REPLACES THE DATALOGGER MANUAL SECTION 2.

SECTION 2. INTERNAL DATA STORAGE

2.1 FINAL STORAGE AND DATA TABLES

Final Storage is that portion of memory where final processed data are stored. It is from Final Storage that data is transferred to your computer. With the TD datalogger, Final Storage is organized into Data Storage Tables. These data tables should not be confused with the program tables *1, *2, and *3 that contain the datalogger program.

Within each data table, data is organized in records and fields. Each row in a table represents a record and each column represents a field. To understand the concept of tables it may be helpful to consider an example. A CR10X is to be used to monitor 3 thermocouples (TC). Each hour a temperature for each of the three TC is to be stored. The table has 4 fields: "DATE_TIME TEMP1 TEMP2 TEMP3." Each hour a new "record" would be added. The "hourly" table would then be organized as follows:

DATE_TIME	TEMP1	TEMP2	TEMP3
01/27/91 10:00:00	23.5	24.6	28.2
01/27/91 11:00:00	24.2	22.4	23.4

Only the hourly data is stored in the hourly table, Each output interval has its own table. Data tables can also be "event driven" rather than interval driven, that is a new record is stored when a specified event occurs rather than based on time. Each table is completely independent of any other tables and all records in a given table have the same number of fields.

Each table is allocated (manually by the user or automatically by the datalogger) a number of records. Different tables have different numbers of records. Each data table is in a ring memory configuration such that when the allocated number of records has been stored, each subsequent new record will overwrite the oldest stored record. The *9 Mode may be used to view the size of the Data Storage Tables. (Section 1.9)

The TD datalogger supports naming of tables and fields, so any data value can be referenced by the table and field names. For example, the

temperature data for the first thermocouple is referenced as "HOURLY.TEMP1." As Data Tables are allocated in the datalogger program, some Final Storage Memory is reallocated for the storage of these labels and other data table overhead.

NOTE: All Data Storage Tables are reallocated and erased whenever the datalogger program is recompiled (*0, *6, *B), when Input Storage Memory is reallocated (*A), or when a new datalogger program is transferred from the computer to the datalogger. ALWAYS RETRIEVE UNCOLLECTED DATA BEFORE MAKING ANY CHANGES.

A time stamp and record number are automatically included with the each record in each table. These are used as part of the data collection protocol.

2.1.1 TIME AND TIMESTAMPS

Each record in a table has a time stamp associated with it. With Instruction 84 set for interval output (a interval in seconds is specified as the second parameter), time is not actually stored with each record. Using the timestamp of the last record stored and the table interval, the datalogger can calculate the timestamp for any previous record. When retrieved, each record in the data file will have a timestamp. This saves 6 bytes per record by not storing time with each record. A consequence of not storing time is that if output does not occur at a scheduled time, the datalogger must keep track of the discontinuity in the timestamps so it can correctly calculate timestamps for records older than the missing record. The datalogger will keep track of the 10 most recent discontinuities in each table. If more than ten discontinuities occur, records with timestamps older than the oldest discontinuity cannot be reliably timestamped when collected. For this reason interval tables should not be used if outputs will be routinely missed. Outputs can be missed (discontinuities can occur) when:

- The datalogger clock is changed such that it passes an output interval.

TD ADDENDUM—SECTION 2. INTERNAL DATA STORAGE

- The output interval is not an even multiple of the scan rate (table execution interval).
- Table execution is such that Instruction 84 is not executed each scan.
- Table overruns occur.
- Watchdog errors (E08) occur.

2.1.2 RECORD NUMBERS

In addition to a timestamp, each record has record number. The record numbers are unique within a data table. Record numbers are 4 byte unsigned numbers ranging from 0 to 4,294,967,296. When the datalogger program is compiled the next record number for each table is set to zero.

2.1.3 TABLES AND FIELDS.

There are four "built in" tables. These tables are present when the datalogger is powered on. These tables are named INLOCS, TIMESET, ERRORLOG, and STATUS. The fields within these tables are also already defined with the exception of the INLOCS. The field names for each of the fields is given below. TmStamp is the label for the timestamp and RecNbr is the label for the record number.

TimeSet

TmStamp, RecNbr, OldTime

ErrorLog

TmStamp, RecNbr, Code

Status

TmStamp, RecNbr, Battery, WatchDog, OverRuns, InLocs, PrgmFree, Storage, Tables, DaysFull, Holes, PrgmSig, PromSig, PromID, ObjSrlNo

Where the labels are defined as follows:

Battery – Indicates the datalogger battery voltage.

WatchDog – The number of Watchdog Errors (E08). (Maximum 99). Section 3.10

OverRuns – Program table overruns that have occurred (Maximum 99). Section 1.1.1.

InLocs – Number of Input Location that have been allocated. Section 1.5.2

PrgmFree – Amount (bytes) of program memory remaining. Section 1.5.2

Storage – Number of Final Storage Locations available for Data Storage Tables. Section 1.5.2

Tables – Number of user created Data Tables.

DaysFull – Size (in days) of the Data Storage Tables using automatic record allocation. See Instruction 84.

Holes – Number of missed records or holes in all Data Storage Tables. Section 2.1.1

PrgmSig – Signature of program memory program. Same as *B mode first window. Section 1.6.

PromSig – Signature of datalogger PROM. Same as *B mode second window. Section 1.6.

Prom ID – Item number of PROM. Same as *B mode seventh window. Section 1.6.

ObjSrlNo – Object code serial number of PROM. Same as *B mode eighth window. Section 1.6.

Like the InLocs table, a new Status record is always available when the datalogger is checked for data. For this reason the Status table is usually collected for display rather than archive.

InLocs

TmStamp, RecNbr, Flags, Ports, Loc1, Loc2, Loc3, Loc4, Loc5, Loc6, Loc7, Loc8, Loc9

Like the Status table, a new InLocs record is always available when the datalogger is checked for data. For this reason these tables are usually collected for display rather than archive.

By default only nine Input Location are labeled. The default InLocs field labels can be replaced with user created labels. These labels are created with EDLOG technique for Input Location labels. Press CTRL-L when editing a LOC field.

When additional data tables are created with Instruction 84, these tables and the fields they contain can also be named by the user. The datalogger will supply a default name for tables and fields if they are not named. The default names are T01, T02, for the tables and F01, F02, etc. for the fields, numbered in the order they appear. Edlog allows the programmer to name the tables and fields.

The Timestamp and record number labels are added automatically.

2.2 DATA OUTPUT FORMAT AND RANGE LIMITS

Data is stored internally in Campbell Scientific's Binary Final Storage Format (Appendix C.2). Data may be sent to Final Storage in either LOW RESOLUTION or HIGH RESOLUTION format.

2.2.1 RESOLUTION AND RANGE LIMITS

Low resolution data is a 2 byte format with 4 significant digits and a maximum magnitude of +7999. High resolution data is a 4 byte format (see Section 2.2.2).

TABLE 2.2-1. Resolution Range Limits of CR10 Data

<u>Resolution</u>	<u>Zero</u>	<u>Minimum Magnitude</u>	<u>Maximum Magnitude</u>
Low	0.000	+ 0.001	+7999.
High	0.0000	1x10 ⁻¹⁹	+9x10 ⁺¹⁸

The resolution of the low resolution format is reduced to 3 significant digits when the first (left most) digit is 8 or greater. Thus, it may be necessary to use high resolution output or an offset to maintain the desired resolution of a measurement. For example, if water level is to be measured and output to the nearest 0.01 ft., the level must be less than 80 ft. for low resolution output to display the 0.01 ft. increment. If the water level was expected to range from 50 to 90 feet the data could either be output in high resolution or could be offset by 20 ft. (transforming the range to 30 to 60 ft.).

2.2.2 HIGH RESOLUTION FINAL STORAGE DATA, INPUT, AND INTERMEDIATE STORAGE DATA FORMAT

While low resolution output data have the limits described above, computations are done in floating point arithmetic. In high resolution Final Storage Input and Intermediate Storage, the numbers are stored and processed in a binary format with a 23 bit binary mantissa and a 6 bit binary exponent. The largest and smallest numbers that can be stored and processed are 9 x 10¹⁸ and 1 x 10⁻¹⁹, respectively. The size of the number determines the resolution of the

arithmetic. A rough approximation of the resolution is that it is better than 1 in the seventh digit. For example, the resolution of 97,386,924 is better than 10. The resolution of 0.0086731924 is better than 0.000000001.

A precise calculation of the resolution of a number may be determined by representing the number as a mantissa between .5 and 1 multiplied by 2 raised to some integer power. The resolution is the product of that power of 2 and 2⁻²⁴. For example, representing 478 as .9336 * 2⁹, the resolution is 2⁹ * 2⁻²⁴ = 2⁻¹⁵ = 0.0000305. A description of Campbell Scientific's floating point format may be found in Appendix C.

2.3 DISPLAYING STORED DATA ON KEYBOARD/DISPLAY *7 MODE.

The keyboard display (or the computer in Keyboard/Display mode) can be used to examine Data Storage Tables in Final Storage table data.

Key *7. The display will show: 07:nn where nn is the number of Data Storage Tables defined. Enter a table number (followed by the "A" key) to view that table. Tables are numbered in the order of the appearance of the Data Storage Table Instruction (84) in the datalogger program. Tables in the *1 program area are numbered first, followed by *2 and those in the *3 subroutines numbered last.

The display will then show the first field of the newest record in the table. If the display does not change, the select table has not had any data stored in it yet.

When a table is visualized the newest data record is at the bottom and the oldest is at the top. When the table is full and a new record is stored, the records shift up pushing the oldest record off the top and storing the new record at the bottom.

The display (or value displayed on the computer) can be thought of as a cursor, which can be moved up and down or right and left through the data. The display shows the field number to the left of the colon and the data value to the right. The keys used to move the display/cursor are summarized in the following table:

TD ADDENDUM—SECTION 2. INTERNAL DATA STORAGE

TABLE 2.3-1. *7 Mode Command Summary

<u>KEY</u>	<u>ACTION</u>
A	"Advances" along a record, when the end of the record is reached the 'cursor' advances to the first field in the next record.
B	"Backs" up along a record, wraps to the last element in the previous record
C	"Climbs" up the table, toward the oldest data, stops on oldest record.
D	"Drops" down the table, toward the newest data, stops on newest record.
#	Enter Time Mode to display timestamp. Enter new time values to jump to record.

Each record of data in a table has a time associated with it. Event data stores the time as part of the data, interval tables calculate the time based on the interval and a reference time. The time associated with each record consist of a year, month/day, hour/minute, and seconds value. Julian dates are not used. When viewing data in the *7 mode, event data records have time as part of the record. The field number on the keyboard/display does not change while viewing the four time values since time is considered a single field. Interval data does not contain time and it is not displayed as part of the record. To see the time values for a given record, press the # key while viewing any of the fields within the record.

The A and B key are used move through the four time values for the record. The C and D keys can be used to move to newer or older records and view the same time value of the new record. Pressing the # key again while viewing time or using the A or B keys to advance or back beyond the time values will return the display to the same field as was displayed when the time mode was entered.

The time field is displayed as: day.month, year, hr:min, seconds

While viewing time, entering new time values will allow the display to jump to the record with time values closest to those entered. The jump takes place when the time mode is left.

Interval tables do not store time as part of the record, but calculate the time. A table 10

records long is maintained inside Intermediate Storage to keep track of "holes" in the recorded data, due to watch dog errors or clock changes, so that the time of each record can be implicitly maintained.

This "hole" table rings around, and any recorded data that cannot be time stamped using this "hole" table cannot be displayed.

To view the "hole" table for a given table, Key *7. The display will show: 07:nn, where nn is the number of Data Storage Tables defined. Enter the number of table where you want to view the "holes." Then press the C key followed by the A key. The Hole table fields are as follows:

01:time of hole;
02:number of holes.

SECTION 3. INSTRUCTION SET BASICS

Section 3.7.1 does not apply to the TD operating system which does not use Output Flag 0.

Table 3.8-1 Valid Flag Commands are 11 – 19 to set high and 21- 29 to set low. Because the TD operating system does not use Flag 0, Commands 10 and 20 are not valid with the TD operating system.

The following table replaces Table 3.10-1 for the TD operating system.

TABLE 3.10-1. Error Codes					
Code	Type	Description			
			29	Compile	Output table requests more memory than available
03	Editor	Program table full	30	Compile	IF and/or LOOP nested too deep
04	Compile	Intermediate Storage full	31	Run Time	SUBROUTINES nested too deep
05	Compile	Storage Area #2 not allocated	32	Compile	Instruction 3 and interrupt subroutine use same port
08	Run Time	CR10X reset by watchdog timer	33	Compile	Cannot use Control Port 6 as counter or interrupt subroutine with Instruction 15 or SDM or SDI-12 input/output
09	Run Time	Insufficient Input Storage			
10	Run Time	Low Battery Voltage			
11	Editor	Attempt to allocate more Input or Intermediate Storage than is available	40	Editor	Instruction does not exist
20	Compile	SUBROUTINE encountered before END of previous subroutine	41	Editor	Incorrect execution interval
21	Compile	END without IF, LOOP or SUBROUTINE	43	Compile	Time in Instruction 84 or 92 is not a multiple of execution interval (note: time is in seconds)
22	Compile	Missing END	44	Compile	Loop (P87) cannot contain Data Table (P84)
23	Compile	Nonexistent SUBROUTINE	60	Compile	Insufficient Input Storage
24	Compile	ELSE in SUBROUTINE without IF	61	Compile	Burst Measurement Scan Rate too short
25	Compile	ELSE without IF	62	Compile	N<2 in FFT
26	Compile	EXIT LOOP without LOOP	68	Compile	Instruction 118 without enough Instructions 68 or 63
27	Compile	IF CASE without BEGIN CASE	80	Compile	Illegal Interval in P193
28	Compile	At compile time, no output specified after P84 or unable to automatically allocate at least one record per P84	81	Compile	Illegal Node ID in P193
			82	Compile	Illegal Reps in P193
			92	Compile	Instruction 92, intervals in seconds: Time into Interval > 59 or Interval > 60

TD ADDENDUM—SECTION 3. INSTRUCTION SET BASICS

94	Program Transfer	Program Storage Area full
95	Program Transfer	Program does not exist in Flash memory
96	Program Transfer	Addressed device not connected
97	Program Transfer	Data not received within 30 seconds
98	Program Transfer	Uncorrectable errors detected
99	Program Transfer	Wrong file type or editor error

THIS SECTION ENTIRELY REPLACES THE CR10X MANUAL SECTION 8.

SECTION 8. PROCESSING AND PROGRAM CONTROL EXAMPLES

This section contains examples for the CR10X. The appropriate voltage range codes would have to be selected for the CR23X (see CR23X Manual Section 8 for the measurement instructions). The CR510-TD may not support all the examples.

The following examples are intended to illustrate the use of Processing and Program Control Instructions, flags, and the capability to direct the results of Output Processing Instructions to Input Storage.

The specific examples may not be as important as some of the techniques employed, for example:

Directing Output Processing to Input Storage is used in the Running Average and Rainfall Intensity examples (8.1 and 8.2).

Flag tests are used in the Running Average, Interrupt Subroutine, and Converting Wind Direction (8.1, 8.5, and 8.7).

Control ports and the Loop are illustrated in the AM32 example (8.3).

As in Section 7 these examples are not complete programs to be taken verbatim. They need to be altered to fit specific needs.

8.1 COMPUTATION OF RUNNING AVERAGE

It is sometimes necessary to compute a running average (i.e., the average covers a fixed number of samples and is continuously updated as new samples are taken). Because the output interval is shorter than the averaging period, Instruction 71 cannot be used; the algorithm for computing this average must be programmed by the user. The following example demonstrates a program for computing a running average.

In this example, each time a new measurement is made (in this case a thermocouple temperature) an average is computed for the 10 most recent samples. This is done by saving all 10 temperatures in contiguous input locations and using the Spatial Average Instruction (51) to compute the average. The temperatures are stored in locations 11 through 20. Each time the table is executed, the new measurement is stored in location 20 and the average is stored in location 2. The Block Move Instruction (54) is then used to move the temperatures from locations 12 through 20 down by 1 location; the oldest measurement (in location 11) is lost when the temperature from location 12 is written over it.

Input Location Labels:

1:Panl Temp 15:Temp_i5
2:smpl10av 16:Temp_i4

11:Temp_i9 17:Temp_i3
12:Temp_i8 18:Temp_i2
13:Temp_i7 19:Temp_i1
14:Temp_i6 20:Temp_i

Where i is current reading, i1 is previous reading, etc.

*	1	Table 1 Programs
01:	10	Sec. Execution Interval
01:	P17	Module Temperature
01:	1	Loc [:Panl_Temp]
02:	P14	Thermocouple Temp (DIFF)
01:	1	Rep
02:	1	2.5 mV slow Range
03:	1	IN Chan
04:	1	Type T (Copper-Constantan)
05:	1	Ref Temp Loc Panl_Temp
06:	20	Loc [:Tempi]
07:	1	Mult
08:	0	Offset
03:	P51	Spatial Average
01:	10	Swath
02:	11	First Loc Temp_i9
03:	2	Avg Loc [:smpl10av]
04:	P54	Block Move
01:	9	No. of Values
02:	12	First Source Loc Temp_i8
03:	1	Source Step
04:	11	First Destination Loc
		[:Temp_i9]
05:	1	Destination Step

TD ADDENDUM—SECTION 8. PROCESSING AND PROGRAM CONTROL EXAMPLES

```

05:   P84      Data Table
    01:   0      Seconds into interval
    02:   0      Every time
    03:   0      Records (0=auto; -=redirect)
06:   P70      Sample
    01:   1      Reps
    02:   2      Loc smpl10avg
07:   P        End Table 1
    
```

In the above example, all samples for the average are stored in input locations. This is necessary when an average must be output with each new sample. In most cases, averages are desired less frequently than sampling. For example, it may be necessary to sample some parameter every 5 seconds and output every hour an average of the previous three hours' readings. If all samples were saved, this would require 2160 input locations. The same value can be obtained by computing an hourly average and averaging the hourly averages for the past three hours. To do this requires that hourly averages be stored in input locations.

Instruction 84 is used to send the 1 hour average to Input Storage and again to send the 3 hour average to Final Storage.

Input Location Labels:

```

1:AVG_i2
2:AVG_i1
3:AVG_i
4:AVG_3_HR
5:XX_mg_M3
    
```

```

*       1      Table 1 Programs
    01:   5      Sec. Execution Interval
01:   P2      Volt (DIFF)
    01:   1      Rep
    02:  25      2500 mV 60 Hz rejection Range
    03:   3      IN Chan
    04:   5      Loc [:XX_mg_M3 ]
    05:  10      Mult
    06:   0      Offset
02:   P84      Data Table
    01:   0      Seconds into interval
    02: 3600      Seconds interval
    03:  -3      Records (0=auto; -=redirect)
03:   P71      Average
    01:   1      Rep
    02:   5      Loc XX_mg_M3
04:   P51      Spatial Average
    01:   3      Swath
    
```

```

02:   1      First Loc AVG_i2
03:   4      Avg Loc [:Avg_3_HR ]
05:   P84      Data Table
    01:   0      Seconds into interval
    02: 3600      Seconds interval
    03:   0      Records (0=auto; -=redirect)
06:   P70      Sample
    01:   1      Reps
    02:   4      Loc Avg_3_HR
07:   P92      If time is
    01:   0      seconds into a
    02: 3600      second interval
    03:  30      Then Do
08:   P54      Block Move
    01:   2      No. of Values
    02:   2      First Source Loc AVG_i1
    03:   1      Source Step
    04:   1      First Destination Loc
                [:AVG_i2 ]
    05:   1      Destination Step
09:   P95      End
10:   P        End Table 1
    
```

8.2 RAINFALL INTENSITY

In this example, the total rain for the last 15 minutes is output only if any rain has occurred. The program makes use of the capability to direct the output of Output Processing Instructions to Input Storage.

Every 15 minutes, the total rain is sent to Input Storage. If the total is not equal to 0, output is redirected to Final Storage Area 1, the time is output and the total is sampled.

Input Location Labels:

```

1:Rain_mm
2:TOT_15mm
    
```

```

*       1      Table 1 Programs
    01:  60      Sec. Execution Interval
01:   P3      Pulse
    01:   1      Rep
    02:   1      Pulse Input Chan
    03:   2      Switch closure
    04:   1      Loc [:Rain_mm ]
    05:  .254    Mult
    06:   0      Offset
02:   P86      Do
    01:  21      Set low Flag 1
    
```

TD ADDENDUM—SECTION 8. PROCESSING AND PROGRAM CONTROL EXAMPLES

```

03:   P92   If time is
01:     0   seconds into a
02:   900   second interval
03:    11   Set high Flag 1

04:   P84   Data Table
01:     0   Seconds into interval
02:    -1   When flag 1 is high
03:    -2   Records (0=auto; -=redirect)

05:   P72   Totalize
01:     1   Rep
02:     1   Loc Rain_mm

06:   P89   If X<=>F
01:     2   X Loc TOT_15min
02:     1   =
03:     0   F
04:    21   Set low Flag 1

07:   P84   Data Table
01:     0   Seconds into interval
02:    -1   When flag 1 is high
03:     0   Records (0=auto; -=redirect)

08:   P70   Sample
01:     1   Reps
02:     2   Loc TOT_15min

09:   P     End Table 1
    
```

gradients. A 107 Temperature Probe is centrally located on the multiplexer board and used as a thermocouple temp. reference.

The AM416 switches the 223 moisture block out of the circuit when it is not being measured. This eliminates the need for the blocking capacitors used in the model 227 Soil Moisture Block. The 223 blocks are about one fifth the cost of the 227 blocks.

Control ports are used to reset the AM416 and clock it through its channels. The program sequence is:

Measure the 107 probe located at the AM416 for TC temperature reference.

CR10 sets the port high which resets the AM416.

A loop is entered; within each pass:
 The port clocking the AM416 is pulsed.
 The connected TCs and moisture blocks are measured.

CR10 sets the port controlling AM416 reset low.

Soil moisture measurements are converted to block resistances.

The input location in which the temperature and soil moisture measurements are stored is indexed to the loop counter (Instruction 87, Section 12). An indexed location is incremented by one with each pass through the loop. For example, on the first pass temperature is stored in Location 2, and soil moisture in Location 18. On the second pass temperature is stored in Location 3, and soil moisture in Location 18. After 16 loop passes, temperature and soil moisture measurements occupy Locations 2 through 17 and 18 through 33, respectively. Connections are shown in Figure 8.3-1.

8.3 USING CONTROL PORTS AND LOOP TO RUN AM416 MULTIPLEXER

This example uses an AM416 to measure 16 copper-constantan thermocouples and 16 Model 223 soil moisture blocks. The sensors are read every ten minutes and the average value output once an hour. The multiplexer is housed in an AM-ENCT enclosure to minimize thermocouple errors created by thermal

TD ADDENDUM—SECTION 8. PROCESSING AND PROGRAM CONTROL EXAMPLES

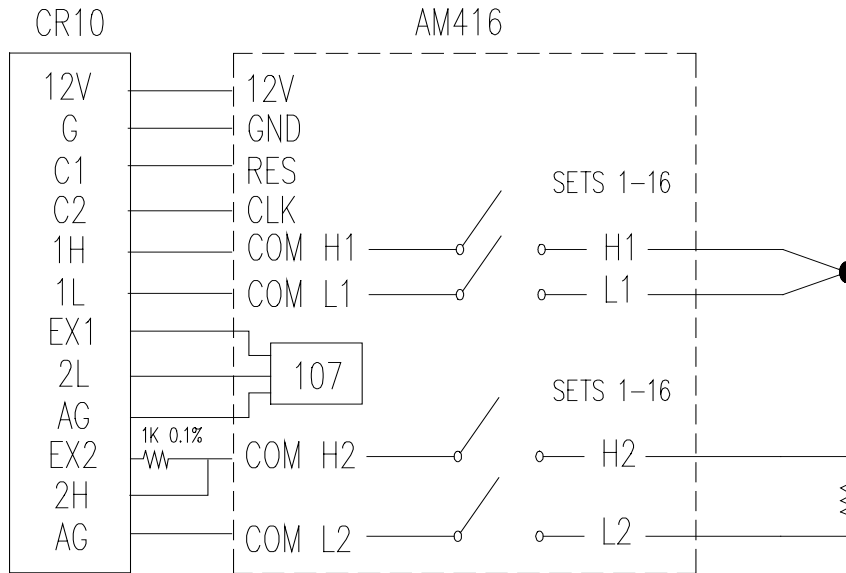

FIGURE 8.3-1. AM416 Wiring Diagram For Thermocouple and Soil Moisture Block Measurements

EXAMPLE PROGRAM MULTIPLEXING THERMOCOUPLES AND SOIL MOISTURE BLOCK

			06:	P5	AC Half Bridge
			01:	1	Rep
			02:	14	250 mV fast Range
			03:	3	IN Chan
			04:	1	Excite all reps w/EXchan 1
			05:	250	mV Excitation
			06:	18--	Loc [:SOIL_M_1]
			07:	1	Mult
			08:	0	Offset
			07:	P95	End
			08:	P86	Do
			01:	51	Set low Port 1
			09:	P59	BR Transform $Rf[X/(1-X)]$
			01:	16	Reps
			02:	18	Loc [:SOIL_M_1]
			03:	.1	Multiplier (Rf)
			10:	P84	Data Table
			01:	0	Seconds into interval
			02:	3600	Seconds interval
			03:	0	Records (0=auto; -=redirect)
			11:	P71	Average
			01:	33	Reps
			02:	1	Loc REF_TEMP
			12:	P	End Table 1
*	1	Table 1 Programs			
01:	600	Sec. Execution Interval			
01:	P11	Temp 107 Probe			
01:	1	Rep			
02:	4	IN Chan			
03:	1	Excite all reps w/EXchan 1			
04:	1	Loc [:REF_TEMP]			
05:	1	Mult			
06:	0	CR10X			
02:	P86	Do			
01:	41	Set high Port 1			
03:	P87	Beginning of Loop			
01:	0	Delay			
02:	16	Loop Count			
04:	P86	Do			
01:	72	Pulse Port 2			
05:	P14	Thermocouple Temp (DIFF)			
01:	1	Rep			
02:	21	2.5 mV 60 Hz rejection			
		Range			
03:	1	IN Chan			
04:	1	Type T (Copper-Constantan)			
05:	1	Ref Temp Loc REF_TEMP			
06:	2--	Loc [:TC_TEMP_1]			
07:	1	Mult			
08:	0	Offset			

8.4 INTERRUPT SUBROUTINE USED TO COUNT SWITCH CLOSURES (RAIN GAGE)

Subroutines given the label of 97 or 98 will be executed when control ports 7 or 8, respectively, go high (5 V, see Instruction 85, Section 12). In this example, Subroutine 98 and control port 8 are substituted for a pulse counting channel to count switch closures on a tipping bucket rain gage.

The subroutine adds 0.254 (mm, bucket calibrated for 0.01 inch tip) to an input location and uses Instruction 22 to delay 0.2 seconds.

The delay is to insure that any switch bouncing (when closing, the contacts actually bounce off each other, making and breaking the circuit several times) has died out before the subroutine is completed. (The pulse count inputs do this automatically.) Without the delay, the subroutine could be completed and called again by a bounce, causing false counts. The interrupt has no effect while the subroutine is still being executed.

Subroutine 98 is in effect keeping a running total in Input Storage. On the output interval, this total is sampled to Final Storage and zeroed by the program in Program Table 1.

To provide comparison, this example has the 2 pulse inputs also reading rain gages. (In a real situation, it is more likely that the pulse counters would be used for 2 wind speeds.) In Program Table 1, the 2 normal pulse inputs are read and the hourly totals output to Final Storage with Instruction 72.

The rain gage is connected as diagrammed below. When the switch closes, 5 volts is applied to port 8 which causes the subroutine to be executed.

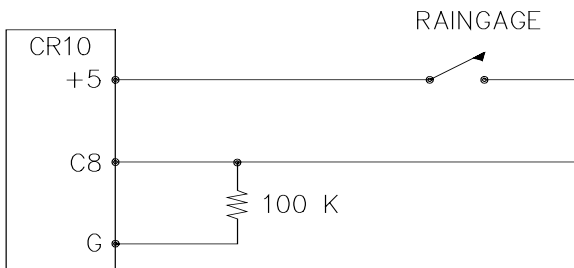

FIGURE 8.4-1. Connections for Rain Gage

Input location Assignments:

10:Rain_1	(from Pulse count)
11:Rain_2	(from Pulse count)
12:Rain_3	(from subroutine 98 while Output Flag is low)
* 1 Table 1 Programs	
01: 10	Sec. Execution Interval
01: P3	Pulse
01: 2	Reps
02: 1	Pulse Input Chan
03: 2	Switch closure
04: 10	Loc [:Rain_1]
05: .254	Mult
06: 0	Offset
02: P84	Data Table
01: 0	Seconds into interval
02: 3600	Seconds interval
03: 0	Records (0=auto; -=redirect)
03: P72	Totalize
01: 2	Reps
02: 10	Loc Rain_1
04: P70	Sample
01: 1	Reps
02: 12	Loc Rain_3
05: P92	If time is
01: 0	seconds into a
02: 3600	second interval
03: 30	Then Do
06: P30	Z=F
01: 0	F
02: 0	Exponent of 10
03: 12	Z Loc [:Rain_3]
07: P95	End
08: P	End Table 1
* 3 Table 3 Subroutines	
01: P85	Beginning of Subroutine
01: 98	Subroutine Number
02: P	34 Z=X+F
01: 12	X Loc Rain_3
02: .254	F
03: 12	Z Loc [:Rain_3]
03: P22	Excitation with Delay
01: 1	EX Chan
02: 0	Delay w/EX (units=.01sec)
03: 20	Delay after EX (units=.01sec)
04: 0	mV Excitation
04: P95	End
05: P	End Table 3

8.5 SDM-A04 ANALOG OUTPUT MULTIPLEXER TO STRIP CHART

This example illustrates the use of the SDM-A04 4 Channel Analog Output Multiplexer to output 4 analog voltages to strip chart.

While of questionable value because of current requirements and strip chart reliability, some archaic regulations require strip chart backup on weather data. The SDM-A04 may be used with the CR10 to provide analog outputs to strip charts. The output values in this example are wind speed, wind direction, air temperature, and solar radiation.

Instruction 103 is used to activate the SDM-A04. The 4 millivolt values to output must be stored in adjacent Input Storage locations, the first of which is referenced in Instruction 103.

The following program measures the sensors every 5 seconds. The readings are moved to another 4 locations and scaled to a 0 to 1000 millivolt output for the SDM-A04. Wind direction is changed from a 0-360 degree input to output representing 0 to 540 degrees. This conversion is done in a subroutine which is described in the next example.

The example also includes instructions to output wind vector and average temperature and solar radiation every hour.

Input Location Labels:

- 1:WS
- 2:WD_360
- 3:TEMP_F
- 4:Solar_Rad
- 5:WS_output
- 6:WD540_out
- 7:TEMP_out
- 8:SR_out
- 10:WD_540

- * 1 Table 1 Programs
- 01: 5 Sec. Execution Interval
- 01: P3 Pulse
- 01: 1 Rep
- 02: 1 Pulse Input Chan
- 03: 22 Switch closure; Output Hz.
- 04: 1 Loc [:WS]
- 05: 1.789 Mult
- 06: 1 Offset
- 02: P4 Excite,Delay,Volt(SE)
- 01: 1 Rep
- 02: 14 250 mV fast Range

- 03: 1 IN Chan
- 04: 1 Excite all reps w/EXchan 1
- 05: 5 Delay (units .01sec)
- 06: 1000 mV Excitation
- 07: 2 Loc [:WD_360]
- 08: .7273 Mult
- 09: 0 Offset
- 03: P11 Temp 107 Probe
- 01: 1 Rep
- 02: 2 IN Chan
- 03: 2 Excite all reps w/EXchan 2
- 04: 3 Loc [:Temp_F]
- 05: 1.8 Mult
- 06: 32 Offset
- 04: P1 Volt (SE)
- 01: 1 Rep
- 02: 2 7.5 mV slow Range
- 03: 3 IN Chan
- 04: 4 Loc [:Solar_Rad]
- 05: .14493 Mult
- 06: 0 Offset
- 05: P54 Block Move
- 01: 4 No. of Values
- 02: 1 First Source Loc WS
- 03: 1 Source Step
- 04: 5 First Destination Loc [:WS_output]
- 05: 1 Destination Step
- 06: P86 Do
- 01: 1 Call Subroutine 1
- 07: P53 Scaling Array (A*loc +B)
- 01: 5 Start Loc [:WS_output]
- 02: 10 A1 Scale WS, 0-100 MPH = 0-1000 MV
- 03: 0 B1
- 04: 1.8519 A2 Scale WD, 0-540 DEG = 0-1000 MV
- 05: 0 B2
- 06: 5.7143 A3 Scale TEMP, -25 - 100 F = 0-1000 MV
- 07: 25 B3
- 08: 1000 A4 Scale RADIATION, 0-1KW/M^2 = 0-1000 MV
- 09: 0 B4
- 08: P103 SDM-A04
- 01: 4 Reps
- 02: 30 Address
- 03: 5 Loc WS_output
- 09: P84 Data Table
- 01: 0 Seconds into interval
- 02: 3600 Seconds interval
- 03: 0 Records (0=auto; -=redirect)

TD ADDENDUM—SECTION 8. PROCESSING AND PROGRAM CONTROL EXAMPLES

10:	P69	Wind Vector	02:	P89	If X<=>F
01:	1	Rep	01:	10	X Loc WD_540
02:	180	Samples per sub-interval	02:	3	>=
03:	0	Polar Sensor/(S, D1, SD1)	03:	270	F
04:	1	Wind Speed/East Loc WS	04:	30	Then Do
05:	2	Wind Direction/North Loc WD_360	03:	P86	Do
11:	P71	Average	01:	11	Set high Flag 1
01:	2	Reps	04:	P94	Else
02:	3	Loc Temp_F	05:	P86	Do
12:	P	End Table 1	01:	21	Set low Flag 1

8.6 CONVERTING 0-360 WIND DIRECTION OUTPUT TO 0-540 FOR STRIP CHART

If 0-360 degree wind direction is output to a strip chart the discontinuity at 0/360 will cause the pen to jump back and forth full scale when the winds are varying from the north. In the days of strip charts this was solved with a 0-540 degree pot on the wind vane (direction changes from 540 to 180 and from 0 to 360 so the pen only jumps once when the wind is out of the north or south).

When faced with the necessity of strip chart output (see previous example), the following algorithm can be used to change a 0-360 degree input to 0-540. (If you have a 0-540 pot, it can be used with the CR10 since the Wind Vector Instruction, 69, will work with this output.)

To change 0-360 degrees to the 0-540 degrees, 360 degrees must sometimes be added to the reading when it is in the range of 0 to 180. The following algorithm does this by assuming that if the previous reading was less than 270, the vane has shifted through 180 degrees and does not need to be altered. If the previous 0-540 reading was greater than 270, 360 degrees is added.

This example is written as a subroutine, used by the previous example to output an analog voltage to a strip chart.

Input Location Labels:

2:WD_360
6:WD540_out
10:WD_540

*	3	Table 3 Subroutines
*	3	Table 3 Subroutines
01:	P85	Beginning of Subroutine
01:	1	Subroutine Number

07:	P31	Z=X
01:	2	X Loc WD_360
02:	10	Z Loc [:WD_540]
08:	P89	If X<=>F
01:	10	X Loc WD_540
02:	4	<
03:	180	F
04:	30	Then Do
09:	P91	If Flag/Port
01:	11	Do if flag 1 is high
02:	30	Then Do
10:	P34	Z=X+F
01:	10	X Loc WD_540
02:	360	F
03:	10	Z Loc [:WD_540]
11:	P31	Z=X
01:	10	X Loc WD_540
02:	6	Z Loc [:WD540_out]
12:	P95	End
13:	P95	End
14:	P95	End
15:	P	End Table 3

8.7 LOGARITHMIC SAMPLING USING LOOPS

A ground water pump test requires that water level be measured and recorded according to the following schedule.

TD ADDENDUM—SECTION 8. PROCESSING AND PROGRAM CONTROL EXAMPLES

Time into Test, min	Output Interval	Loop #
00 to 10	10 sec.	1
10 to 30	30 sec.	2
30 to 100	1 min.	3
100 to 300	2 min.	4
300 to 1000	5 min.	5
1000 and greater	10 min.	6

This is accomplished with a series of loops (Instruction 87), where the delay and count parameters are used to implement the frequency of measurement (and output) and the duration of the that frequency. The unit of delay is the execution interval. A delay of 1 with a 10 second execution interval and a count of 60 means the instructions in the loop, in this case measure and output water level, are executed every 10 seconds for 10 minutes.

The drawdown portion of the test is completed at some time greater than 1000 minutes. To enter the recharge phase of the test, the operator enters the *6AD Mode and sets Flag 1 high. At the next 10 minute pass through loop 6 the loop is exited. Program execution returns to the top of the program table and the measurement schedule starts over again for the recharge test.

The sensor is a 50 PSI Druck, model 930/ti with a calibration of 49.93 mV/10V of excitation or 4.993mV/V. Your calibration will be different. An excitation voltage of 1500 mV yields a maximum signal of 7.489 mV at 50 PSI, fully utilizing the 7.5 mV Input Range to provide the best resolution.

The multiplier, m, is calculated to provide depth of water in feet:

$$m = (50 \text{ psi}/4.993 \text{ mV/V}) * (2.3067 \text{ ft/psi})$$

$$m = 23.099 \text{ ft/mV/V}$$

The offset is calculated to provide a final value that represents the distance from the lip of the well to the water surface. Similar to Figure 7.16-2, the offset equals the initial distance of 47.23 feet plus the initial reading of 54.77, or 102 feet.

* 1 Table 1 Programs
01: 10 Sec. Execution Interval

User must toggle Flag 1 to start measurements

01: P91 If Flag/Port
01: 21 Do if flag 1 is low
02: 0 Go to end of Program Table

Loop 1, Output every 10 seconds for 10 minutes

02: P87 Beginning of Loop
01: 1 Delay
02: 60 Loop Count

03: P86 Do
01: 1 Call Subroutine 1

04: P95 End

Loop2, Output every 30 seconds for 20 minutes

05: P87 Beginning of Loop
01: 3 Delay
02: 40 Loop Count

06: P86 Do
01: 1 Call Subroutine 1

07: P95 End

Loop 3, Output every 1 minute for 70 minutes

08: P87 Beginning of Loop
01: 6 Delay
02: 70 Loop Count

09: P86 Do
01: 1 Call Subroutine 1

10: P95 End

Loop 4, Output every 2 minutes for 200 minutes

11: P87 Beginning of Loop
01: 12 Delay
02: 100 Loop Count

12: P86 Do
01: 1 Call Subroutine 1

13: P95 End

Loop 5, Output every 5 minutes for 700 minutes

14: P87 Beginning of Loop
01: 30 Delay
02: 140 Loop Count

15: P86 Do
01: 1 Call Subroutine 1

16: P95 End

TD ADDENDUM—SECTION 8. PROCESSING AND PROGRAM CONTROL EXAMPLES

Loop 6, Output every 10 minutes until stopped by user

17:	P87	Beginning of Loop
01:	60	Delay
02:	0	Loop Count
18:	P86	Do
01:	1	Call Subroutine 1
19:	P91	If Flag/Port
01:	21	Do if flag 1 is low
02:	31	Exit Loop if true
20:	P95	End
21:	P	End Table 1
*	3	Table 3 Subroutines
01:	P85	Beginning of Subroutine
01:	1	Subroutine Number
02:	P6	Full Bridge
01:	1	Rep
02:	22	7.5 mV 60 Hz rejection Range
03:	1	IN Chan
04:	1	Excite all reps w/EXchan 1
05:	1500	mV Excitation
06:	1	Loc [:LEVEL_FT]
07:	.46199	Mult
08:	102	Offset
03:	P84	Data Table
01:	0	Seconds into interval
02:	0	Every time
03:	0	Records (0=auto; -=redirect)
04:	P70	Sample
01:	1	Reps
02:	1	Loc LEVEL_FT
05:	P95	End
06:	P	End Table 3

TD ADDENDUM—SECTION 8. PROCESSING AND PROGRAM CONTROL EXAMPLES

SECTION 9. INPUT/OUTPUT INSTRUCTIONS

*** 18 MOVE TIME TO INPUT LOCATION ***

FUNCTION

This instruction takes current time or date information and does a modulo divide (see Instruction 46) on the time/date value with the number specified in the second parameter. The result is stored in the specified Input Location.

Entering 0 or a number greater than the maximum value of the time/date for the modulo divide will result in the actual time/date value being stored.

PARAMETER 1 CODES

Code	Time/Date Units
00	Seconds into day (maximum 86400)
01	Minutes into day (maximum 1440)
02	Hours into year (maximum 8784)
03	Hours into day (maximum 24)
04	Day of month (maximum 31)
05	Month of year (maximum 12)
06	YR MO DAY HR MIN SEC

PARAM NUMBER	DATA TYPE	DESCRIPTION
01:	2	Time/Date Code
02:	4	Number to modulo divide by
03:	4	Input Location Number

Input Locations altered: 1

SECTION 11. OUTPUT PROCESSING INSTRUCTIONS

Instructions 73 – Maximum and 74 – Minimum have only one time option. (Time is output as a quoted string.) Instruction 80 – Set Active Storage Area, is not in the TD operating system. Its functions are included in Instruction 84 – Data Table. Instruction 84 is only in the TD operating system.

*** 73 MAXIMUM ***

FUNCTION

This instruction stores the MAXIMUM value taken (for each input location specified) over a given output interval. An internal FLAG is set whenever a new maximum value is seen. This FLAG may be tested by Instruction 79. Time of occurrence maximum value(s) is OPTIONAL output information, which is formatted and activated by entering one of the following CODES for Parameter no. 2.

CODE	OPTIONS
00	Output value ONLY
01	Output value with TIME

PARAM. NUMBER	DATA TYPE	DESCRIPTION
01:	2	Repetitions
02:	2	Time of maximum (optional)
03:	4	Starting input location no.

Outputs Generated: 1 for each input location (plus 1 with time of max. option)

*** 74 MINIMUM ***

FUNCTION

Operating in the same manner as Program 73, this instruction is used for storing the MINIMUM value (for each input location specified) over a given output interval.

PARAM. NUMBER	DATA TYPE	DESCRIPTION
01:	2	Repetitions
02:	2	Time of minimum (optional)
03:	4	Starting input location no.

Outputs Generated: 1 for each input location (plus 1 with time of min. option)

*** 84 DATA TABLE ***

FUNCTION

Instruction 84 is used to define a table of final storage data. New records of data are stored in the table based on time (interval data) or when a user flag (CR10X flags 1-8) is set (event data). Time based output intervals are specified in seconds. Fractional values may be used following the same rules that apply for the table scan rate.

PARAM. NUMBER	DATA TYPE	DESCRIPTION
01:	FP	Time into interval (Seconds)
02:	FP	Time interval (Seconds) 0 = Store new record each time. -a = Store if user flag "a" is set (a=1..8)
03:	FP	Number of records in table 0 = automatically allocates number of records. If 0 and parameter 2 = -a (event driven) or if 0 and parameter 2 = 0 then allocates size as if a 1 second output table -x = redirect to input loc x

Parameter 1 specifies how many seconds into the interval, specified in parameter 2, data will be output to final storage. If the output is event driven, enter a 0 for parameter 1.

Parameter 2 specifies the output interval (seconds) for the table. If output is determined by a flag, -a should be used, ('a' is the flag to be tested). If Parameter 2 = 0, data will be output unconditionally each time Instruction 84 is executed.

Parameter 3 specifies how many records will be stored in the table. When the table is full, subsequent new records will overwrite the oldest

TD ADDENDUM—SECTION 11. OUTPUT PROCESSING INSTRUCTIONS

records. If 0 is entered, records will be automatically allocated such that all automatic tables will be filled at the same time. If some tables specify the number of records and some tables are automatically allocated, the specified records will be allocated first, and then the remaining memory will be divided among the automatically allocated tables such that they will be filled at the same time. The Star 9 mode gives the size of all tables and the period (in days) before any automatically allocated table fills. If -x is entered, the processed results are returned to input locations.

Section 12. Program Control Instructions

The TD operating system does not use the output Flag 0. Commands dealing with it are not valid.

Instructions 96 – Serial Output, 98 – Send Character, and 111 – Load Program from Flash, are NOT in the TD operating system.

The instructions described in this section are only in the PakBus operating system.

Wireless Networks

More recent CR10X, CR510, and CR23X dataloggers with the PakBus operating system use the PakBus communications protocol. In addition to providing a robust means of packet based communication, the protocol allows transfer of input location data from one datalogger to another, or from a Campbell Scientific wireless sensor/datalogger (CR200 series datalogger) to a "host" (or "master") TD datalogger.

The following is some general information on the requirements for successful communication in a PakBus network.

Datalogger Requirements

PakBus communication requires the current PakBus operating system in the CR10X, CR510, or CR23X datalogger. All CR200 Series dataloggers are capable of PakBus communication.

All dataloggers in the PakBus network require a unique address. The address for TD dataloggers is set in the *D15 mode. The address for the CR200 datalogger's is set using Pakcom software or LoggerNet version 2.1 or greater.

Communication Notes

PakBus dataloggers are also capable of Modbus communication. The Modbus packet can ride on top of the PakBus packet or can be send independently. Instruction 190 is used to set up a datalogger as a Modbus master device. The datalogger's Modbus address is set in the *D8 mode of the datalogger. The Modbus and Pakbus addresses for a datalogger cannot be the same.

In order to communicate to a datalogger via another datalogger from LoggerNet's Connect window (e.g., communicating with a CR205 via a CR10XTD-PB) the datalogger through which you will be communicating must be set as a router. This is done by entering the number of remote dataloggers that the router will be connecting to in the *D15 mode, parameter 2.

The PakBus instructions described in this section are often used in combination with a CR200 series datalogger and the RF400 series spread spectrum radio. Table 12-1 lists some of the advantages and disadvantages of different methods of transferring data.

TABLE 12-1. CR205/CR210/CR215 in PakBus Network

	Stand Alone Datalogger	SendGetData P190	Wireless Sensor P193
General Description	CR205 is programmed as a stand alone datalogger. Data are stored in datalogger and retrieved by computer running Loggernet	May be used as either a wireless sensor interface (data stored in “Master” Logger) or to transfer data to another logger while still independently storing data.	“Master” datalogger stores all data and sets transmission schedule for remote CR205 w/ sensors.
PRO	<ul style="list-style-type: none"> Data are stored in Datalogger, loggernet will automatically retry if communication fails. No special datalogger programming required for data transfer 	<ul style="list-style-type: none"> Most flexible datalogger to datalogger data transfer. Can be set to automatically retry sending data. 	<ul style="list-style-type: none"> Potential for lowest power consumption by remote CR205. Data are collected only from “Master” datalogger. Automatic retries if adequate time is allocated
CON/limitations	<ul style="list-style-type: none"> Separate data files for each logger. 	<ul style="list-style-type: none"> Both the “Remote Sensor” CR205 and the Master Datalogger need to be programmed to handle the data. Data collection should be scheduled to avoid conflicts with datalogger to datalogger communication. 	<ul style="list-style-type: none"> Both the “Remote Sensor” CR205 and the Master Datalogger need to be programmed to handle the data. Without storing data in the sensor, data are lost if transmission fails. Master radio must be on continuously. For simplicity, all wireless sensor CR205s should have the same sensors. (or at least no more than 4 different sensor configurations) Data collection should be scheduled to avoid conflicts with Sensor to Master communication.
PakBus Instructions used in Datalogger Programming	Normal programming to measure sensors, process, and store data.	SetValue, GetValue, or P190 in datalogger initiating communication. Programming to deal with any sent data or codes in the other datalogger.	Wireless Network Master (P193) in master datalogger. TimeUntilTransmit (or P194) and SendGetData (or P196) in remote.

	Stand Alone Datalogger	SendGetData P190	Wireless Sensor P193
Radio Settings	<i>Radio address, net address, and hop sequence must be the same in all CR2xxs and RF400s in the network. Because only one header length can be set for a radio, only one power cycling interval should be used in network; i.e., do not mix 8 second and 1 second interval radio power cycling. RF on (no cycling) is specified where necessary below.</i>		
CR205 Power Mode and Header	Select power mode for appropriate response time and current drain.	Select power mode for appropriate response time and current drain. Header must match called station's cycle.	NO HEADER. RfpinEn (lowest power) or to allow communication with computer for checking station, downloading program: RF8_Sec or RF1_sec.
RF400 on CR10X or CR23X	Router, if used, must send appropriate header	Router, if used, must send appropriate header	RF on, <i>header to match CR205 setting to allow contacting CR205</i>
Beacon Interval	0	0	0
RF400 on computer	RF on, <i>header to match neighbors' settings</i>	RF on, <i>header to match neighbors' settings</i>	RF on, <i>header to match neighbors' settings</i>
LoggerNet Settings <i>When RF400 with direct access to network is connected to computer.</i>	<i>For each datalogger:</i> Com -PbusPort -logger	<i>For each datalogger with stored data:</i> Com -PbusPort -logger	<i>For each master datalogger:</i> Com -PbusPort -logger

PakBus Get/Send Locations (P190)

A program control instruction that sends data to or retrieves data from another datalogger in a PakBus network. This instruction can also be used to issue commands to Modbus devices, where the datalogger acts as a Modbus master.

```

1: PakBus - Get/Send Locations (P190)
1: 00      Port
2: 0000    Address
3: 00      Command
4: 0000    Security
5: 0000    Remote Loc/Coil/Register
6: 0000    Swath
7: 0000    Local Loc [ _____ ]
8: 0000    Result Code Loc [ _____ ]
    
```

Notes:

Edlog allocates only one of the input locations used in parameters 5 and 7 of this instruction. The additional input locations must be inserted manually using the Input Location Editor.

If this instruction is used to retrieve a value or set a value in the remote datalogger's public (or input location) table (i.e., code 26 or 27 is used in parameter 3), Instruction 63 or 68 must follow this instruction to enter the variable name that will be accessed.

Index parameter 3 to delay execution of subsequent program instructions until the datalogger receives a valid response or error from the remote. Otherwise, the PakBus command is queued, the datalogger proceeds to the next instruction, and the communications are handled later when the remote replies.

Port

The communications port that will be used by the local PakBus datalogger during the execution of this instruction. Valid options are:

Code	Description
0	Modem Enabled Device, 300
1	Modem Enabled Device, 1200
2	Modem Enabled Device, 9600
3	Modem Enabled Device, 76800
4	Modem Enabled Device, 2400
5	Modem Enabled Device, 4800
6	Modem Enabled Device, 19200
7	Modem Enabled Device, 38400
16	SDC 6 (COM 310)
17	SDC 7
18	SDC 8

Note: The CR10X-TD and CR510-TD have limited communication rates and do not support options 4 through 7.

Address

When a PakBus command is being issued, this address refers to the PakBus address of the datalogger. When a Modbus command is being issued, this address refers to the Modbus address. The PakBus and Modbus addresses in the datalogger cannot be set to the same number.

If this instruction is used within a loop, index this parameter to automatically increment the address with each pass through the loop. When this parameter is indexed, program execution will be delayed until a response is received from the remote datalogger.

PakBus Communication

The unique address for the datalogger in the PakBus network that will be communicated with using this instruction.

The Pakbus address is set in the datalogger's *D15 mode.

Modbus Communication

The unique address for the datalogger in a Modbus network that will be communicated with using this instruction (the slave device).

The Modbus address is set in the datalogger's *D8 mode. The valid range of IDs for a Modbus slave device are 1 - 99. Setting the datalogger's Modbus address to 0 disables it as a Modbus slave.

Command

This parameter determines what type of communication should take place in the PakBus or Modbus network when the instruction is executed.

Command	Description
1	Read Coil Status (Modbus command)
2	Read Input Status (Modbus command)
3	Read Holding Registers (Modbus command)
4	Read Input Registers (Modbus command)
5	Force Single Coil (Modbus command)
15	Force Multiple Coils (Modbus command)
16	Preset Multiple Registers (Modbus command)
21	Receive input location data from another datalogger (Pakbus command)
22	Send input location data to another datalogger (Pakbus command)
26	Get Value
27	Set Value
61	Read Coil Status (Modbus command)
62	Read Input Status (Modbus command)
63	Read Holding Registers (Modbus command)
64	Read Input Registers (Modbus command)
65	Force Single Coil (Modbus command)
66	Force Multiple Coils (Modbus command)
67	Preset Multiple Registers (Modbus command)

Notes:

Codes 61 through 67 are used when the Modbus packet will ride on top of Pakbus as a datagram.

If Get Value or Set Value is used (26 or 27), parameter 5 is left blank and Instruction 63 or 68 is used following this instruction to enter the variable name in the datalogger's Public (or input locations) table that will be accessed.

If this parameter is indexed, the datalogger will proceed to the next instruction only after it receives a valid response or error from the remote. Otherwise, the PakBus command is queued, the datalogger proceeds to the next instruction, and the communications are handled later when the remote replies. It may be

desirable to delay execution of subsequent instructions if those instructions perform further processing on the response from the remote.

Security

Enter the level 2 security code for the remote datalogger in the PakBus network that will be communicated with using this instruction when Command 22 is used for parameter 3 (send input location data to another datalogger).

If the security code in this instruction does not match the security code of the remote datalogger, the remote datalogger will discard the message, and the failure will be indicated in the local datalogger by an incremental change in the Result Code Location (parameter 8).

If security is not set in the remote datalogger or if command 21 is used for parameter 3, this parameter can be left at 0.

For additional information on security codes, see Program Security.

Enter the level 2 security code for the remote datalogger in the PakBus network that will be communicated with using this instruction when Command 22 is used for parameter 3 (send input location data to another datalogger).

If the security code in this instruction does not match the security code of the remote datalogger, the remote datalogger will discard the message, and the failure will be indicated in the local datalogger by an incremental change in the Result Code Location (parameter 8).

If security is not set in the remote datalogger or if command 21 is used for parameter 3, this parameter can be left at 0.

Remote Location/Coil/Register

PakBus Communication

If data is being received from another datalogger in the PakBus network (Parameter 3 set to 21), this is the first input location in the remote datalogger from which to retrieve the data.

If data is being sent to another datalogger in the PakBus network (Parameter 3 set to 22), this is the first input location in the remote datalogger in which to store the first data value.

If a variable in the Public (or Input Locations) table is being accessed using Get Value or Set Value (Parameter 3 set to 26 or 27), this parameter is left blank and Instruction 63 or 68 is used following this instruction to enter the variable name.

Modbus Communication

This is the first coil or register to be acted upon when the instruction is executed.

For general information on input locations, see Input Locations.

Remote Location

PakBus Communication

If data is being received from another datalogger in the PakBus network (Parameter 3 set to 21), this is the first input location in the remote datalogger from which to retrieve the data.

If data is being sent to another datalogger in the PakBus network (Parameter 3 set to 22), this is the first input location in the remote datalogger in which to store the first data value.

Modbus Communication

This is the first coil or register to be acted upon when the instruction is executed.

Swath

PakBus Communication

The number of input locations that will be sent to or retrieved from the remote datalogger.

Modbus Communication

The number of subsequent coils or registers that will be acted upon when the instruction is executed.

Local Location

PakBus Communication

If data is being received from another datalogger in the PakBus network (Parameter 3 set to 21), this is the first input location in which to store the data.

If data is being sent to another datalogger in the PakBus network (Parameter 3 set to 22), this is the first input location for the swath of input locations that will be sent to the remote datalogger.

Notes:

If Command code 21 is chosen, the number of input locations required for the transferred data must be allocated manually.

If this instruction is used within a loop, index this parameter to automatically increment the input locations with each pass through the loop. The input locations for this parameter are calculated as the number of passes through the loop * the swath of locations, plus one location (for the response).

Modbus Communication

The input location that is the source or the destination of the information that will be transferred when this instruction is executed. Discrete values are packed

or unpacked with the least significant bit of the first byte, starting at this location. Incoming discrete values are set to -1.0 for ON and 0 for OFF. Outgoing discrete values are translated as 0.0 to OFF and non-zero to ON.

For general information on input locations, see Input Locations.

Result Code Location

The input location in which to store the results of the data transfer.

Result	Description
0	Successful
>0	Initial attempt failed (value indicates the number of retries)

Up to 2 retries will be attempted if data transfer fails. The retry interval is 1 second, plus $1/2 * \text{number of hops}$ for the node. The instruction runs in the background after initiated.

Note: If this instruction is used within a loop, index this parameter to automatically increment the input location in which the result is stored with each pass through the loop.

Send Final Storage Data (P191)

A program control instruction that transfers final storage data from one or more tables in a PakBus datalogger to a computer.

```
2: PakBus - Send Final Storage Data (P191)
1: 00      Port
2: 0000    Address
3: 0000    Table ID
4: 00      Flag
```

Table ID

The ID for the data table that should be sent to the computer using this instruction. If the ID is set to 0, then all final storage tables will be transferred.

Flag

The user flag that will determine if the table definitions are transferred along with the data table(s). When the flag is high, the table definitions for the specified table(s) will be output as a separate data gram.

Send Message (P192)

A program control instruction that sends a message to another datalogger in the PakBus network.

This instruction can be used in a network with several Master dataloggers to synchronize all Master datalogger's clocks. One datalogger would use this instruction to periodically broadcast a clock report, and the remaining dataloggers would use instruction 195, Use Remote Clock Report, to set their clocks by the transmitted value.

This instruction is not necessary in networks with wireless sensors and only one Master datalogger, because the Wireless Network Master (P193) and Wireless Network Remote (P196) instructions perform these functions automatically.

This instruction can also be used to remove a datalogger from the PakBus network.

```

3: PakBus - Send Message (P192)
1: 00      Port
2: 0000    Address
3: 2       Clock Report

```

Message Type

Entry	Description
2	Clock report; sends the current time.
13	The datalogger that receives this message will remove the sending datalogger from its neighbor list (and therefore all links to the sending datalogger).

Wireless Network Master (P193)

A program control instruction that is used to prepare the local datalogger to send data to or receive data from one or more dataloggers/wireless sensors in a PakBus network. The instruction also assigns a transmission time to the remote dataloggers/wireless sensors. Instruction 193 does not actually initiate the transfer of data. Data transfer is initiated by the wireless sensor.

Multiple Instruction 193s can be used in a program to configure up to four different groups of dataloggers/wireless sensors. A "group" is determined by the First Remote Address and the Number of Remotes. A datalogger/wireless sensor can only belong to one group. An error message will occur (E81) if a datalogger/wireless sensor is assigned to more than one group.

```

4: PakBus - Wireless Network Master (P193)
1: 00      Number of Remotes
2: 0000    First Remote Address
3: 0000    Time Into Transmit Interval (sec)
4: 0000    Transmit Interval (sec, 0 = use execution interval)
5: 00      Transmit Delay Between Remotes (sec)
6: 00      Swath to Receive
7: 0000    First Loc for Data Received [ _____ ]
8: 00      Swath to Send
9: 0000    First Loc to Send [ _____ ]
10: 0000   Result Code Loc [ _____ ]

```

Notes:

The wireless sensors will actually begin transmitting before the specified transmission time (based on Time Into Transmit Interval and Transmit Interval) so that transmission is complete when the specified transmission time occurs. The Transmit Delay Between Remotes is factored into to the transmit time assigned to each remote.

Edlog allocates only one of the input locations used in parameters 7, 9, and 10 of this instruction. The additional input locations must be inserted manually using the Input Location Editor. For information on manually inserting input locations, refer to Manually Inserting Input Locations Into Edlog.

Number of Remotes

The number of remote dataloggers/wireless sensors in the PakBus network that will be communicated with using this instruction.

First Remote Address

The unique address for the first remote datalogger/wireless sensor in the PakBus network that will be communicated with using this instruction. All of the remotes that will be communicated with using this P193 should have sequential addresses.

The address is set in the datalogger's *D15 mode (refer to the datalogger user's manual for additional information). It can be any number between 1 and 4095.

Time into Transmit Interval

An offset, in seconds, into the Transmit Interval. The valid range is 0 through 9998.

Example

To set up the remotes for an hourly transmission at 15 minutes past the hour, the Time into Transmit Interval would be set at 900 and the Transmit Interval would be set at 3600.

Transmit Interval

The transmission interval, in seconds, that will be assigned to the group of dataloggers/remote sensors being set up with this instruction. The valid range is 1 through 9999.

The wireless sensors will actually begin transmitting before the specified transmission time (based on Time Into Transmit Interval and Transmit Interval) so that transmission is complete when the specified transmission time occurs. The Transmit Delay Between Remotes, parameter 5, is factored into the transmit time assigned to each remote.

The datalogger program can be written to execute P193 on every program scan, or within a P92 (If Time) instruction. The Transmit Interval must equal the interval on which Instruction 193 is being executed.

Note: The Transmit Interval must be sufficiently long so that all of the remotes have a chance to respond before the next transmit interval occurs. Therefore, Transmit Interval must be equal to or greater than Number of Remotes * Transmit Delay Between Remotes. You will have to estimate the Transmit Delay Between Remotes if that value (parameter 5) is set to 0 (which means use the estimated value from the datalogger's routing table).

Example

To set up the remotes for an hourly transmission at 15 minutes past the hour, the Time into Transmit Interval would be set at 900 and the Transmit Interval would be set at 3600.

Transmit Delay Between Remotes

The amount of delay, in seconds, between transmission from each remote. If this parameter is left at 0, the master datalogger will automatically assign the delay based on the routing table (usually about 3 seconds between remotes). Otherwise, a specific delay can be entered. A specific delay may be necessary for slow communication links.

Some communications links do not require a delay (such as when communicating over an NL100). In this instance, the parameter can be left at 0 and indexed.

Code	Description
0	Use the default, as determined by the routing table
>0	Use the value entered
--0	Use no delay (dashes are accomplished by indexing the parameter)

Note: The wireless sensors will actually begin transmitting before the specified transmission time (based on Time Into Transmit Interval and Transmit Interval) so that transmission is complete when the specified transmission time occurs. The Transmit Delay Between Remotes is factored into to the transmit time assigned to each remote.

Example

Assume 4 wireless remotes in a network, with the first having an address of 1 and the remainder of the remotes addressed consecutively. The transmission time is set at 900 seconds into a 3600 second interval (15 minutes past each hour). If Transmit Delay Between Remotes is set at 5, Remote 4 will transmit at about 15 seconds before the transmit time, Remote 3 at about 10 seconds before, Remote 2 at about 5 seconds, and Remote 1 at the transmit time.

Swath to Receive

The number of data values that will be received from each remote when data is transferred. If a remote sends less than the number of values indicated by the swath, the remaining locations will be filled with an overrange value (-99999). If a remote sends more than the number of data values indicated by the swath, the extra values will be discarded by the local datalogger.

First Location for Data Received

The first input location in which the first data value received from the first remote should be stored. Subsequent data values from the group of remotes will be stored in consecutive input locations.

Note: The number of input locations required for the transferred data (Number of Remotes * Swath to Receive) must be allocated manually.

For general information on input locations, see Input Locations.

Swath to Send

The number of data values that will be sent to each remote when data is transferred.

First Location to Send

The input location which holds the first value that should be sent to the dataloggers/wireless sensors in the group. The range of values sent to the remote(s) is determined by the Swath to Send parameter (parameter 8).

For general information on input locations, see Input Locations.

Result Code Location

The input location in which a code is stored to indicate the result of the data transfer. A 0 indicates the data transfer was successful; any number greater than 0 indicates a failure.

Note: One Result Code Location is required for each remote (specified by Number of Remotes, parameter 1). These input locations must be allocated manually.

When the datalogger receives a wireless message from a remote, the corresponding Result Code Location is set to -1. When Instruction 193 is executed, the Result Code Location is incremented by 1. Therefore, if communication is successful, the Result Code Location will be 0 after the execution of Instruction 193. If data transfer is unsuccessful, the Result Code Location for the remote that failed will be incremented, and will continue to increment with each failed attempt.

Seconds Until Transmit (P194)

A program control instruction that places in an input location the number of seconds until it is time to transmit data to the host datalogger. This instruction is used in conjunction with a conditional statement to determine when the Wireless Network Remote instruction (P196) is executed to initiate communication with the host. The communication schedule is determined by the host (or master) datalogger and is set in the remote when it first initiates communication. If no communication has taken place and the value has not been set, or if scheduled communication was not successful, Seconds Until Transmit will return a random offset into a one minute interval.

```
5: PakBus - Seconds Until Transmit (P194)
1: 0000   Loc with Seconds Until Transmit [ _____ ]
```

Note: If the datalogger is not being used as a wireless sensor (i.e., Instruction 196 is not in the program), this instruction can be used to place a random number of seconds into a minute interval in the specified input location. The random seed is based on the datalogger's PakBus address.

Location with Seconds Until Transmit

The input location in which to store the number of seconds until it is time to transmit to the host datalogger.

Use Remote Clock Report (P195)

A program control instruction that sets a remote datalogger's clock based on the clock value transmitted from the host (or master) datalogger specified by the address provided in parameter 1.

```
6: PakBus - Use Remote Clock Report (P195)
1: 0000      Address
```

Note: This instruction is not used if the datalogger is configured as a wireless sensor using instruction 196 (Wireless Network Remote). When instruction 196 is used, the remote datalogger will automatically adjust its clock to match the host (master) datalogger's clock whenever communication is successful.

Address

The unique address for the host (master) datalogger in the PakBus network, whose clock value will be used to set the clock in the remote datalogger.

The address is set in the datalogger's *D15 mode (refer to the datalogger user's manual for additional information). It can be any number between 1 and 4095.

Wireless Network Remote (P196)

A program control instruction that is used to set up a remote datalogger to act as a wireless sensor/controller in a PakBus network.

Communication with the host (master) datalogger is dictated by the host datalogger. A communication time is assigned to the remote datalogger when communication is first accomplished with the host. The remote datalogger uses Instruction 194, Seconds Until Transmit, in conjunction with a conditional statement to determine when P196 is executed, and therefore, when data is transferred to the host.

When first installed or when communication is not successful, P194 will indicate a random interval of up to one second. The remote will try to contact the master on this interval until communication is successful and it is programmed with a transmit time.

The remote datalogger's clock is synchronized with the host datalogger's clock, each time communication between the two dataloggers is successful.

```
7: PakBus - Wireless Network Remote (P196)
1: 00      Port
2: 0000    Master Address
3: 0000    Security
4: 00      Swath to Receive from Master
5: 0000    First Loc for Data Received [ _____ ]
6: 00      Swath to Send to Master
7: 0000    First Loc to Send [ _____ ]
8: 0000    Result Code Loc [ _____ ]
```

Swath to Receive From Master

The number of data values that will be received from the host (master) datalogger when data is transferred. If the host sends less than the number of values indicated by the swath, the remaining locations will be filled with an overrange value (-99999). If the host sends more than the number of data values indicated by the swath, the extra values will be discarded by the local datalogger.

First Location for Data Received

The first input location in which the first data value received from the host (master) datalogger should be stored. Subsequent data values from the host will be stored in consecutive input locations.

Notes:

The number of input locations required for the transferred data must be allocated manually.

Security

Enter the level 2 security code for the master datalogger in the PakBus network that will be communicated with using this instruction .

If the security code in this instruction does not match the security code of the master datalogger, the master datalogger will discard the message, and the failure will be indicated in the local datalogger by an incremental change in the Result Code Location (parameter 8).

If security is not set in the master datalogger, this parameter can be left at 0.

For additional information on security codes, see Program Security.

Enter the level 2 security code for the master datalogger in the PakBus network that will be communicated with using this instruction .

If the security code in this instruction does not match the security code of the master datalogger, the master datalogger will discard the message, and the failure will be indicated in the local datalogger by an incremental change in the Result Code Location (parameter 8).

If security is not set in the master datalogger, this parameter can be left at 0.

Swath to Send

The number of data values that will be sent to the host (master) datalogger when data is transferred.

First Location to Send

The input location which holds the first value that should be sent to the host (master) datalogger. The range of values sent is determined by the Swath to Send parameter (parameter 6).

For general information on input locations, see Input Locations.

Result Code Location

The input location in which a code is stored to indicate the result of the data transfer. A 0 indicates the data transfer was successful; any number greater than 0 indicates a failure. A -2 indicates that communication was established with the datalogger at the specified address, but the datalogger was not programmed as a host (master) datalogger using Instruction 193. In this instance, a 0 is stored in parameter 5, First Location for Data Received.

For general information on input locations, see Input Locations.

Force Route (P197)

A program control instruction that is used to force the datalogger to use a specific route in the PakBus network to communicate with the destination datalogger. This information is set in the datalogger's routing table.

```

8: PakBus - Force Route (P197)
1: 00      Port
2: 0000    Neighbor's Address
3: 0000    Address
4: 00      Hops

```

Note: For communications paths where there are multiple hops, this instruction fixes only the first hop.

Neighbor's Address

The address of the first hop (or repeater) in the PakBus network that the datalogger should use in communicating with the destination datalogger.

Hops

The number of hops (or repeaters) in the communications path to the destination datalogger.

Set Setting (P198)

A program control instruction that is used to set a setting in a PakBus datalogger. This instruction should be followed by instruction 63 or instruction 68 with the values for the setting that should be changed.

If the address in this instruction is set to the address of the datalogger executing the instruction, the datalogger will change its own setting.

```

9: PakBus - Set Setting (P198)
1: 00      Port
2: 0000    Address
3: 0000    Result Code Loc [ _____ ]

```

Result Location

Result Code	Description
-1001	The attempted setting is a read-only setting
-1002	Out of space in the remote
-1003	Syntax error
0	Success
>1	Number of communication failures

Routing Table Information (P199)

A program control instruction that is used to store the datalogger's routing table information in a series of input locations. This instruction is used most often as a trouble-shooting tool.

```

10: PakBus - Routing Table Information (P199)
  1: 0000      First Loc [ _____ ]
    
```

Parameter 1 specifies the first input location in which to begin storing the information. For each route, there are 3 pieces of information returned:

1. The PakBus Address of the Destination datalogger.
2. The PakBus address of any datalogger used as a hop to the Destination datalogger.
3. The Response Metric, in seconds (each hop takes 1 second).

A -1 in an input location indicates the end of the routing table information.

Note: The input locations required for this instruction must be allocated manually.

Example

Consider the following routing table information:

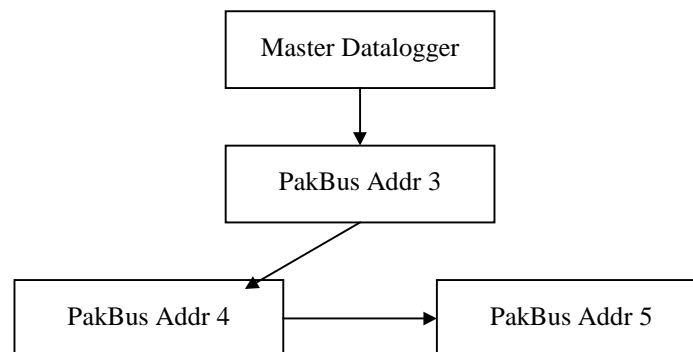

The information returned using this instruction would be similar to:

Input Location Used	Value Stored	Description
1	3	Address of destination datalogger
2	3	Address of repeater datalogger
3	1	Response metric, 1 second (1 hop)
4	4	Address of destination datalogger
5	3	Address of repeater datalogger
6	2	Response metric, 2 seconds (2 hops, 3 & 4)
7	5	Address of destination datalogger
8	3	Address of repeater datalogger (first hop only)
9	3	Response metric, 3 seconds (3 hops, 3, 4 & 5)
10	-1	End of string

PakBus Settings (Options | PakBus Settings)

This dialog box is used to configure some of the PakBus settings, that are normally set in the datalogger's *D mode, when a program is downloaded to the datalogger.

For all of the options below, if the check box Do Not Change Current Settings is enabled, then those settings will not be changed when the program is downloaded to the datalogger.

Network

The Network option is used to set the PakBus address in the datalogger and to configure the datalogger as a router if required. This option is the same as the datalogger's *D19 mode.

Address - Enter the PakBus address that should be assigned to the datalogger.

Maximum number of nodes - Enter the total number of dataloggers in the PakBus network.

Maximum number of neighbors - Enter the number of dataloggers in the PakBus network that the datalogger can communicate with directly (i.e., without going through another datalogger).

Maximum number of routers - Enter the number of neighbors to the datalogger that act as routers to one or more other dataloggers in the PakBus network.

Beacon Intervals

This option is used to set the interval on which the datalogger will transmit a beacon out a particular port to the PakBus network. Use the drop-down list box to select the port over which the beacon will be transmitted, and enter the

desired interval in the Communications Interval field. This option is the same as the datalogger's *D18 mode.

In some networks, a beacon interval might interfere with regular communication in the PakBus network (such as in an RF network), since the beacon is broadcast to all devices within range. In such cases, it may be more appropriate to use the Neighbor Filter instead, which broadcasts a beacon only to those dataloggers which it has not received communication from within a specified interval.

Neighbor Filter

This option allows you to list potential neighbors that are available to the datalogger in the PakBus network. The datalogger will attempt to issue a "hello" command to all the dataloggers listed in the neighbors filter list, and will transmit an expected communication interval. The communication interval is the interval on which the datalogger expects to receive communication from the neighbors. If communication is not received from a neighbor within 2.5 times this interval, then the datalogger will attempt to issue another "hello" command to that datalogger only (thus, creating less network traffic than the Beacon Interval).

The expected interval is entered into the Communication Interval field in seconds. The neighbors are defined by entering their addresses into the table. A range of addresses can be entered by using the Swath field. For example, entering 1 for the address and 5 for the swath will set up dataloggers with PakBus addresses 1, 2, 3, 4, and 5 as neighbors to the current datalogger.

This option is the same as the datalogger's *D19 mode.

Allocate General Purpose File Memory

PakBus dataloggers have the ability to store files transmitted from an NL100 in a general purpose memory area. This memory area is configured as ring memory. A value can be entered to specify the number of 64K blocks of memory that should be used for this purpose. Final storage memory will be reduced by the amount of memory specified in this option. This option is the same as the datalogger's *D16 mode.