

# CS110

---

## Electric Field Meter



# Table of contents

---

<b>1. Introduction</b> .....	<b>1</b>
<b>2. Precautions</b> .....	<b>1</b>
2.1 Lightning safety .....	1
<b>3. Initial inspection</b> .....	<b>2</b>
3.1 Accessories .....	2
<b>4. Overview</b> .....	<b>3</b>
<b>5. Specifications</b> .....	<b>5</b>
<b>6. Installation</b> .....	<b>7</b>
6.1 Site selection .....	7
6.2 Installing the CS110 .....	8
6.3 Power considerations .....	9
6.3.1 Connecting to AC power .....	9
6.4 Seal cable connectors .....	9
6.5 Programming .....	10
6.5.1 CS110() instruction .....	10
6.5.2 CS110Shutter instruction .....	10
6.5.3 Internal relative humidity sensor programming .....	10
6.5.4 Sensor programming .....	11
<b>7. Operation</b> .....	<b>12</b>
7.1 Measurement details .....	12
7.2 CS110 lightning detection example .....	15
7.3 Lightning warning levels .....	16
7.3.1 All Clear .....	17
7.3.2 Caution or Lightning Watch .....	17
7.3.3 Alarm or Lightning Warning .....	18
7.4 Factory calibration of the CS110 .....	19
7.5 Site correction .....	21
<b>8. CS110 maintenance</b> .....	<b>25</b>
8.1 Status codes .....	25

8.2 Changing desiccant .....	27
8.3 Cleaning the CS110 electrode head .....	28
8.4 Checking ground integrity .....	30
8.5 Protecting from corrosion and rust .....	30
8.6 Recalibration .....	31
8.7 Troubleshooting .....	31
<b>9. References .....</b>	<b>32</b>
<b>Appendix A. Connector pin-outs .....</b>	<b>33</b>
A.1 Sensor connectors .....	33
A.2 Power and communications connectors .....	36
<b>Appendix B. Installing a CM106B tripod .....</b>	<b>38</b>
B.1 Tripod base .....	38
B.2 Staking tripod feet .....	39
B.3 Tripod mast .....	39
B.4 Tripod grounding .....	40
<b>Appendix C. Installing a CM110 tripod .....</b>	<b>42</b>
C.1 Tripod base .....	42
C.2 Tripod mast .....	43
C.3 Staking tripod feet .....	44
C.4 Tripod grounding .....	45
<b>Appendix D. Mounting the enclosure on a tripod .....</b>	<b>46</b>
<b>Appendix E. Installing a CM500-series pole .....</b>	<b>48</b>
E.1 Installation in concrete foundation (without a pedestal) .....	48
E.2 Installation with a pedestal .....	50
E.3 Installation with concrete stud anchors and a pedestal .....	52
E.4 Pole grounding .....	53
<b>Appendix F. Mounting the enclosure on a CM500-series pole .....</b>	<b>54</b>
<b>Appendix G. Installing an RA100 remote alarm .....</b>	<b>57</b>
G.1 Mounting on a flat wall (RA1 option) .....	57
G.2 Mounting on a pole or tripod (RA2 option) .....	57
<b>Appendix H. Installing the SG000 Strike Guard .....</b>	<b>58</b>

<b>Appendix I. CS110 as a slow antenna</b> .....	<b>59</b>
I.1 Slow antenna response in frequency domain .....	59
I.2 Slow antenna response in time domain .....	60
I.3 Slow antenna programming .....	62
I.4 Calibration .....	63
<b>Appendix J. Site calibration using transfer standard on CM310s</b> .....	<b>64</b>
J.1 Site calibration .....	65
J.2 Transfer standard installation .....	67
J.3 Site calibration cautions .....	69

# 1. Introduction

---

The CS110 Electric Field Meter measures the electric field and forecasts the likelihood of lightning. In general, the higher the electric field, the greater probability for lightning.

The CS110 has a measurement range of -25,000 to 25,000 V/m and makes measurements every second. It can detect both cloud-to-ground and cloud-to-cloud lightning strikes within a 25-mile radius. Lightning strike detection efficiency is 95% within 5 miles, 93% within 10 miles, and 68% within 20 miles.

Unlike traditional rotating-vane field mills, the CS110 uses a reciprocating shutter that opens and closes by 45° during measurements. The reciprocating shutter is electrically connected to ground potential by a flexible stainless-steel strap, resulting in an ultra-reliable electrical ground connection. By using a zero-field (closed shutter) reference for each measurement, the CS110 offers an improved dc error performance over traditional rotating-vane field mills.

## 2. Precautions

---

- READ AND UNDERSTAND the [Safety](#) section at the back of this manual.
- Atmospheric or local electric field conditions or different site characteristics may cause false information, late data, or otherwise incomplete or inaccurate data. The CS110 only measures conditions that make lightning more likely. Just as with weather forecasts, the CS110 measurements only help assess the probability of lightning. Lightning can occur causing personal injury, even death, or damage to property without any warning from the CS110. Campbell Scientific is not liable for special, indirect, incidental, or consequential damages from the use, failure, or malfunction of the CS110. See [Limited warranty](#) for more information.
- DO NOT install the lightning rod included with the tripod, as it will adversely affect CS110 measurements.

### 2.1 Lightning safety

Lightning warning devices fall into two classes: lightning detectors and electric field monitors. Stand-alone lightning detectors, such as the SG000, provide warning based on nearby discharges, but give no warning until a detectable discharge occurs. Electric field monitors, such

as the CS110, measure the atmospheric electric field, indicating the presence of nearby electrified clouds capable of producing lightning discharges. Consequently, electric field monitors can give warning at the beginning of storms prior to hazardous discharges. Both lightning detectors and electric field monitors are employed in high-risk applications.

**Lightning safety guidelines based on human observations exist and should not be ignored simply because of the presence of sensitive electronic instrumentation.** The NOAA 30/30 rule suggests seeking shelter if thunder is heard within 30 seconds of a lightning flash (approximately 6 miles), and remaining in a sheltered area for 30 minutes after the last lightning or thunder before resuming outdoor activities.

It should be noted that **no method of lightning warning completely eliminates the risks associated with lightning.** As mentioned, lightning detectors give no warning until a detectable discharge has occurred. Atmospheric electric field yields warning prior to the “first strike” for storms developing overhead, along with some indication of the end of a thunderstorm. Yet there are occurrences of cloud-to-ground lightning discharges striking the ground several miles away from the electrified cloud where the discharge initiated [NOAA]. Electric field monitors may give no practical warning in these instances because the electric field in the vicinity of the strike point may not indicate hazardous levels until milliseconds before the strike. Consequently, **while lightning warning systems can greatly reduce the probability of death or injury from lightning discharges, they cannot reduce this probability to zero.**

## 3. Initial inspection

---

- Upon receipt of the sensor, inspect the packaging and contents for damage. File damage claims with the shipping company.
- Immediately check package contents against the shipping documentation. Contact Campbell Scientific about any discrepancies.

### 3.1 Accessories

**CAUTION:**

You must order an embedded CR1000M data logger with the CS110.

The following are shipped with the CS110:

- (1) Calibration Certificate
- (1) Flat-Bladed Screwdriver, 2.5 mm Blade x 50 mm Shaft

- (1) #1 Phillips Screwdriver
- (1) Screw #3-48 Hex Driver Set
- (1) Nylon Electrode Cleaning Brush
- (1) CS110 Stainless-Steel Mast Mounting Bracket
- (1) CM110 Stainless-Steel Body Grounding Clamp
- (2) Screw #10-32 x .500 Pan Phillips, Stainless Steel
- (1) CS110 Stainless-Steel Mast Clamp Bracket
- (4) Screw 1/4-20 x 2.250 Cap Hex, Silicon Bronze
- (4) Stainless-Steel Flat Washer 1/4
- (1) Desiccant 4-Unit Bag
- (1) Black Cold Shrink Tape
- (1) Loctite Anti-Seize Stick

The following accessories (ordered separately) are often shipped with the CS110:

- CS110CBL1-L RS-232 (DTE) cable for connecting to a computer or communications device.
- CS110CBL2-L CS I/O cable for connecting to a Campbell Scientific peripheral device such as the NL201, NL241, and FC100.
- CS110CBL3-L Power cable for connecting to the power supply of another data logger.
- Zero Electric Field Cover for checking the electric field offset voltage of the CS110.
- CS110FV In-Field Verifier for verifying a CS110 factory calibration.

## 4. Overview

---

The CS110 uses a reciprocating shutter instead of the traditional rotating vane field mill. The reciprocating shutter is electrically connected to ground potential by a flexible stainless-steel strap. The strap operates below its fatigue limit, resulting in an ultra-reliable electrical ground connection to the shutter ([FIGURE 4-1](#) (p. 4)).

The reciprocating approach provides better low-frequency error performance than the traditional rotating vane field mill because it has a convenient zero-field (closed shutter) reference. The zero-field reference allows the CS110 to measure and then correct for electronic offset voltages, contact potentials, and leakage currents of each individual measurement (U.S. Patent No. 7,109,698).

The CS110 also contains circuitry to measure and compensate for insulator leakage currents occurring on the charge amplifier input, eliminating measurement errors caused by fouled insulators. If insulator surfaces become conductive because of surface contamination, a leakage current compensation circuit applies an equal and opposite polarity current to the charge-amplifier input that prevents saturation of the electronics.

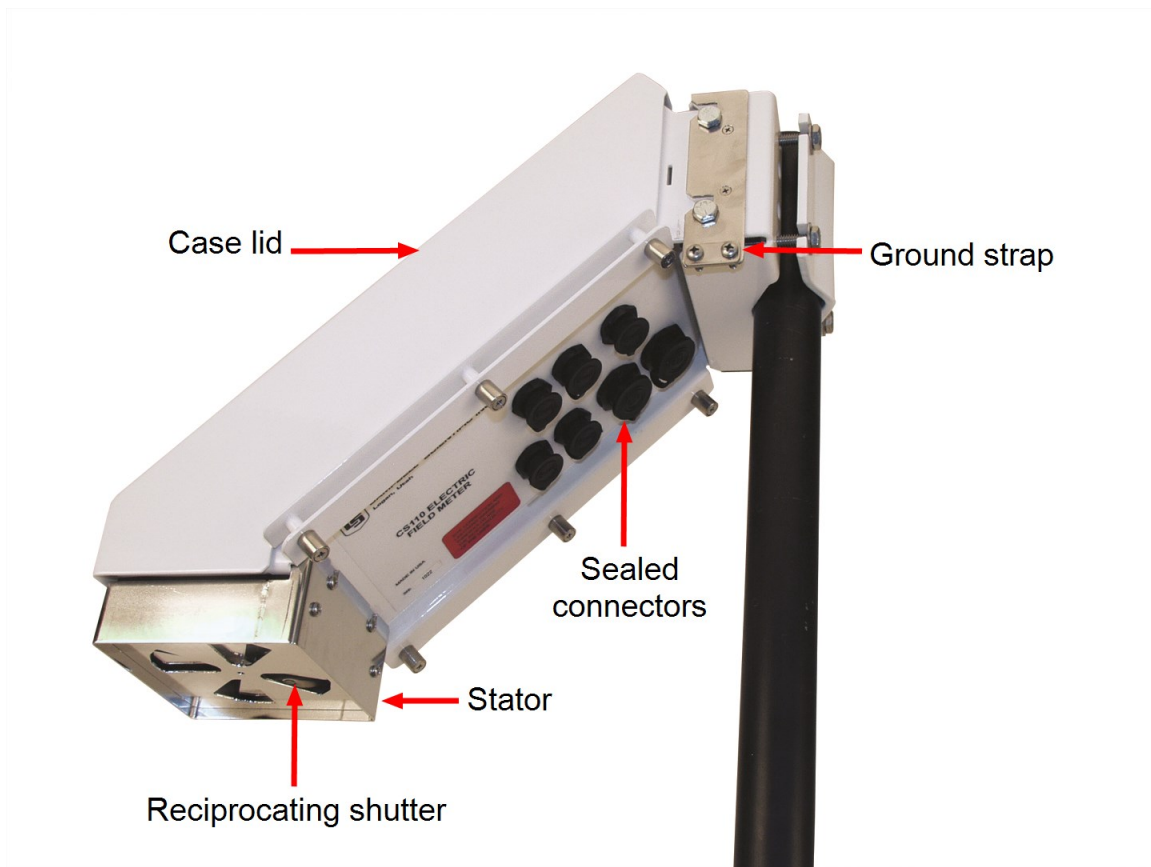

*FIGURE 4-1. CS110 electric field meter*

An embedded CR1000M data logger module is required for every CS110 purchased. The data logger provides measurement and control functions, data processing and storage, and flexible communications options. LoggerNet software (purchased separately) provides versatile networking and data collection capabilities. Communications options compatible with the CR1000 include direct connect, Ethernet, phone modems (land-line and cellular), radios, short haul modems, GOES satellite transmitters, and multidrop modems. For more details on the CR1000 data logger, see the [CR1000 Measurement and Control System Operator's Manual](#).

The CS110 has sealed connectors for attaching meteorological sensors and three digital control ports for controlling external devices and/or triggering alarms.



# 5. Specifications

Table 5-1: Electric Field Measurement Performance

Configuration	Accuracy <sup>1</sup>	Measurement range <sup>2</sup> (V/m)	Resolution (V/m)	Sensitivity (μV/m)	Noise V/m RMS
Parallel Plate	±1% of reading + 60 V/m offset	±(0 to 21,000)	3	12	4.0
		±(21,000 to 212,000)	30	118	18.0
2-meter Tripod <sup>3</sup>	±5% of reading + 8 V/m offset	±(0 to 2,200)	0.32	1.2	0.42
		±(2,200 to 22,300)	3.2	13	1.9

<sup>1</sup>Typical offset for clean electrodes is ≤ |30 V/m| for the parallel-plate configuration, which is reduced by the field enhancement factor for typical inverted and elevated mounting configurations.

<sup>2</sup>The CS110 incorporates automatic gain ranging between two input ranges. The measurement is first tried on the lowest input range. If the signal is too large for the lowest range, the larger range is used.

<sup>3</sup>Field enhancement due to typical inverted and elevated mounting requires additional site correction, estimated at ±5% accuracy when done in appropriate high field conditions. Practical outdoor CS110 electric field measurement accuracy is estimated at ±5% of reading + 8 V/m for the CS110 2-meter Tripod Site.

**Reciprocating shutter patent:** U.S. Patent No. 7,109,698

**Standard mounting height:** 2 m

**Sample rate:** Programmable sample rate up to 5 samples per second  
Variable sample rates possible

**Supply voltage:** 11 to 16 VDC

**Maximum power consumption:** 750 mA during motor operation

**Average power consumption at 12 VDC**

0.1 Hz sample rate: 7 mA (0.08 W)  
1 Hz sample rate: 60 mA (0.7 W)  
2 Hz sample rate: 120 mA (1.4 W)  
5 Hz sample rate: 300 mA (3.6 W)

<b>Communications:</b>	1 RS-232 port 1 CS I/O port (Campbell Scientific peripheral port) 3 digital control ports (SDI-12, alarm, other communications)
<b>RS-232 baud rate:</b>	300 to 115200 bps
<b>Compliance:</b>	View compliance documents at <a href="http://www.campbellsci.com/cs110">www.campbellsci.com/cs110</a>
<b>Lightning protection:</b>	Multi-stage transient protection on all external interfaces
<b>Operating temperature range</b>	
<b>Standard:</b>	-25 to 50 °C
<b>Extended (optional):</b>	-40 to 85 °C
<b>Operating relative humidity range:</b>	0 to 100% RH
<b>Mounting:</b>	Vertical pipe with outer diameter (OD) of 1.91 to 6.35 cm ( 0.75 to 2.5 in)
<b>Physical dimensions:</b>	15.2 x 15.2 x 43.2 cm (6 x 6 x 17 in)
<b>Weight:</b>	4 kg (9 lb)
<b>Construction:</b>	<ul style="list-style-type: none"> <li>• Metallic ground connection to reciprocating shutter (no wiping contact)</li> <li>• Brushless stepper motor</li> <li>• Powder-coated aluminum case</li> <li>• Teflon insulators</li> <li>• Electro-polished 316L stainless steel used for corrosion protection of critical exposed metallic parts</li> </ul>

# 6. Installation

---

Accurate electric field measurements are dependent on a site calibration factor, known as  $C_{\text{site}}$ . To maintain the validity of the site calibration factor, use the information in this section to select a site and install the CS110. If these instructions are not or cannot be followed, new calibration may be required (see [Site correction](#) (p. 21)).

6.1 Site selection .....	7
6.2 Installing the CS110 .....	8
6.3 Power considerations .....	9
6.3.1 Connecting to AC power .....	9
6.4 Seal cable connectors .....	9
6.5 Programming .....	10
6.5.1 CS110() instruction .....	10
6.5.2 CS110Shutter instruction .....	10
6.5.3 Internal relative humidity sensor programming .....	10
6.5.4 Sensor programming .....	11

## 6.1 Site selection

Many factors can distort and/or change the electric field at a given site. Select an appropriate site for the system, far from tall buildings, tall vegetation, and sharp, metal points.

Vegetation growth can reduce the effective height of an elevated instrument above the ground and can create unwanted space-charge due to corona discharge. Gravel rings or concrete pads around a site are recommended to prevent changes in effective instrument height due to vegetation growth. For example, electric field meters used for lightning warning at Kennedy Space Center were each installed on a 8 m (25 ft) radius gravel ring [LPLWS].

Animals and people within the vicinity of an electric field meter can significantly alter the measurements. Fencing off a given site may be best for some applications. However, corona discharge from sharp metal points on even a small fence may cause corruption of measurements of large electric fields.

The presence of aerosols, dust, and automobile exhaust should be considered when selecting an electric field meter site, as they can affect the local electric field.

In theory, the effects of tall nearby objects can be accounted for in a site correction. Yet, because of possible corona current along with general field distortion, it is recommended that electric field meter sites should not be located near tall objects. For example, Kennedy Space Center site requirements stipulate having no objects protruding higher than  $18^\circ$  above the horizon, as seen from the ground at the electric field meter location [LPLWS]. Roof-mounted CS110 systems are practical if a site correction can be done to account for field distortions.

A good earth ground connection to the CS110 and associated mounting hardware is necessary to make a given site appear as a vertical extension of the earth ground. Periodically check the integrity of this earth ground connection by verifying that the resistance of the stator to earth ground rod is  $<1 \Omega$ .

Although the list of factors that can impair electric field measurements is long, experience has shown that useful electric field measurements can be made by paying careful attention to these details.

## 6.2 Installing the CS110

Accurate electric field measurement is dependent on a site calibration factor,  $C_{\text{site}}$ . To maintain  $C_{\text{site}}$  validity, adhere to the following guidelines:

- Nothing should be beneath the CS110.
- Ensure the CS110 is facing the ground and not a tripod leg, solar panel, or enclosure.
- Mount the CS110 with its top 25.4 cm (10 in) below the top of the mast and with its face (where the shutter is) at 2 m (78.75 in) above the ground.

Tighten the mounting bolts to fasten it to the mast.

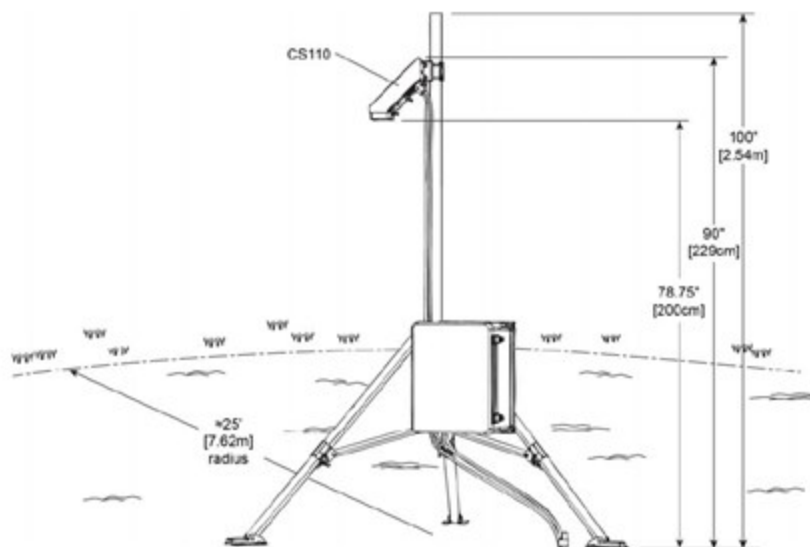

## 6.3 Power considerations

The stepper motor is powered off much of the time, reducing power consumption, making economical remote solar power feasible. The average electric field meter current is a function of the measurement rate. The data logger program can implement variable sample rates based on measured results to conserve power for solar powered applications. For example, the data logger program can measure electric field at a 10-second rate during fair weather conditions, and automatically switch to 1-second measurements during threatening conditions. An example variable sample rate program is available at [www.campbellsci.com/downloads/cs110-programs](http://www.campbellsci.com/downloads/cs110-programs). Like the stepper motor, communications devices that are turned off when not needed, can offer low average power consumption.

The CS110CBL3-L connects a DC power supply to the CS110 **POWER** connector; maximum length is 15 m (50 ft). The CS110 is protected against accidental reversal of the positive and ground wires from the power supply. Transient protection is also included on the power supply inputs. DC input voltages in excess of 18 V may damage the CS110.

### 6.3.1 Connecting to AC power

**WARNING:**

When connecting to AC power, work must be performed by qualified personnel according to local electrical codes.

1. Shut off 110 VAC power at the main breaker.
2. Route the power cable through the enclosure compression fitting. Tighten the compression fitting to secure the cable.
3. With the power cable unplugged, attach the L, N, and G wires of the power cable to the corresponding terminals in the enclosure.
4. Plug the battery connector into the CH150 Charging Regulator.
5. Plug in the power cable.
6. Switch all circuit breakers to on, and turn on the CH150 Charging regulator.

## 6.4 Seal cable connectors

After installing the cables, wrap the included self-vulcanizing tape around the connectors overlapping 2.5 cm (1 in) of the cable. The tape prevents water from entering the connectors or cables.

## 6.5 Programming

Programming basics are provided in the following sections. Complete program examples are available at [www.campbellsci.com/downloads/cs110-programs](http://www.campbellsci.com/downloads/cs110-programs).

### 6.5.1 CS110() instruction

The **CS110()** CRBasic instruction measures electric field. This instruction has the following structure:

```
CS110(Destination, Leakage, Status, Integration, Mult, Offset)
```

**Leakage** is a variable that stores the measured leakage current in nano amps (nA) on the charge amplifier input during the CS110 electric field measurement. A perfect unit is 0 nA. Actual units will have very small (significantly less than 1 nA) positive or negative leakage current. The **Status** variable stores the status code (Table 8-1 (p. 25)). The **CS110()** instruction initially measures the electric field using the  $\pm 250$  mV range. If the result is NAN (not a number), the instruction measures the CS110 using the  $\pm 2500$  mV range. A status code of 1 is returned if the measurement was made on the 250 mV range. A status code of 2 is returned if the measurement was made on the 2500 mV range. A status code of 3 is returned if the measurement overranged on the 2500 mV range.

### 6.5.2 CS110Shutter instruction

The **CS110Shutter()** instruction controls the shutter and has the following structure:

```
CS110Shutter(Status, Move)
```

**Status** is a variable that stores the status code (Status codes (p. 25)). **Move** is set to 1 to open the shutter and set to 0 to close the shutter.

For testing purposes, the **CS110Shutter()** instruction used with a **Delay()** instruction verifies the fully opened and fully closed positioning of the CS110 shutter. Use the **CS110Shutter()** instruction along with a **VoltDiff()** instruction to implement a slow antenna electric field measurement (CS110 as a slow antenna (p. 59)).

### 6.5.3 Internal relative humidity sensor programming

The CS110 includes a relative humidity sensor inside the case. The following CRBasic instruction stores the internal humidity measurements in the variable **Internal\_RH**:

```
VoltDiff(Internal_RH, 1, mV2500, 5, True, 0, 250, 0.1, 0)
```

Change the CS110 desiccant when the average internal relative humidity readings are greater than 20%.

## 6.5.4 Sensor programming

Table 6-1 (p. 11) shows compatible sensors. This section includes examples of CRBasic instructions used to measure meteorological sensors follows. Refer to the sensor manuals and [Sensor connectors](#) (p. 33) for additional programming information.

Connector	Compatible sensors (one sensor per connector) <sup>1</sup>
RAIN	TE525 Rain Gage
WIND	05103 wind speed and temperature sensor
TEMP/RH	107 temperature probe, 108 temperature probe, HMP60 temperature and relative humidity sensor, or EE181
SOLAR RADIATION	CS305-ET pyranometer, CS100 barometer <sup>2</sup> , CS106 barometer <sup>2</sup> , GPS16X-HVS GPS Receiver with Integrated Antenna

<sup>1</sup>Choose the -C cable termination option (except for the CS305-ET, barometers, and GPS16X-HVS).

<sup>2</sup>The barometers use the CS110 to Barometric Pressure Sensor Cable to connect to the CS110, and must be housed in a separate enclosure.

### RAIN connector

Example CRBasic instructions for measuring the TE525:

```
PulseCount(rain_fall,1,2,2,0,0.01,0) 'TE525 tipping bucket 0.01 inches per tip
```

### WIND connector

Example CRBasic instructions for measuring the 01503:

```
PulseCount (wind_speed,1,1 ,1,1,0.2192,0) 'Wind Speed.  
BrHalf (wind_dir,1,mV2500,4,Vx2,1,2500,False,450,_60Hz,355,0) 'Wind Direction.
```

### TEMP/RH connector

Example CRBasic instructions for measuring the EE181:

```
SW12(1) 'Turn on switched 12V  
Delay(0,2,Sec) '2-second delay  
'EE181 Temperature & Relative Humidity Sensor measurements AirTC and RH:  
VoltSe(AirTemp,1,mV2500,2,0,0,_60Hz,0.1,-40)  
VoltSe(RH,1,mV2500,1,0,0,_60Hz,0.1,0)  
SW12(0) 'Turn off switched 12V
```

## SOLAR RADIATION connector

Example CRBasic instruction for measuring the CS305 pyranometer:

```
'Measure the CS305  
Voltdiff (solar_rad,1,mV7_5,3,True,450,_60Hz,200,0)
```

# 7. Operation

---

This section discusses the following.

7.1 Measurement details .....	12
7.2 CS110 lightning detection example .....	15
7.3 Lightning warning levels .....	16
7.3.1 All Clear .....	17
7.3.2 Caution or Lightning Watch .....	17
7.3.3 Alarm or Lightning Warning .....	18
7.4 Factory calibration of the CS110 .....	19
7.5 Site correction .....	21

## 7.1 Measurement details

The charge amplifier circuitry of the reciprocating electric field meter is depicted in [FIGURE 7-1](#) (p. 13). Induced charge on the sense electrode results in the operational amplifier placing charge on the feedback capacitor CF to restore the sense electrode to virtual ground.



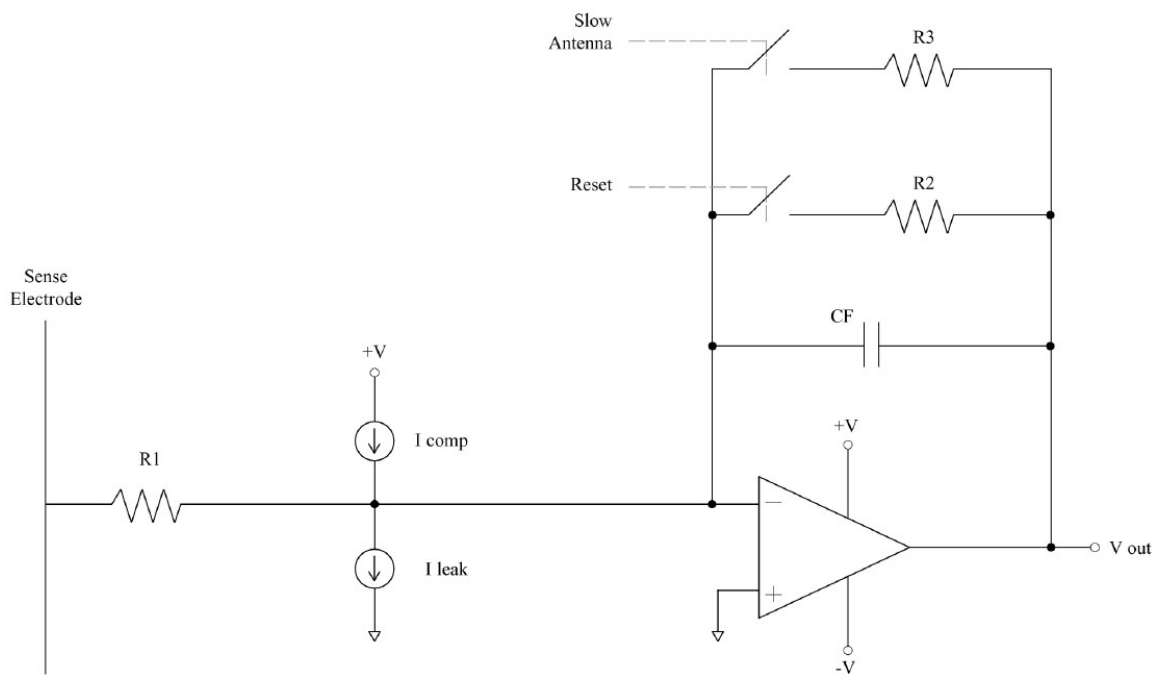

FIGURE 7-1. Charge amplifier circuitry of reciprocating electric field meter

The charge amplifier output during a measurement cycle of the reciprocating electric field meter is shown below.

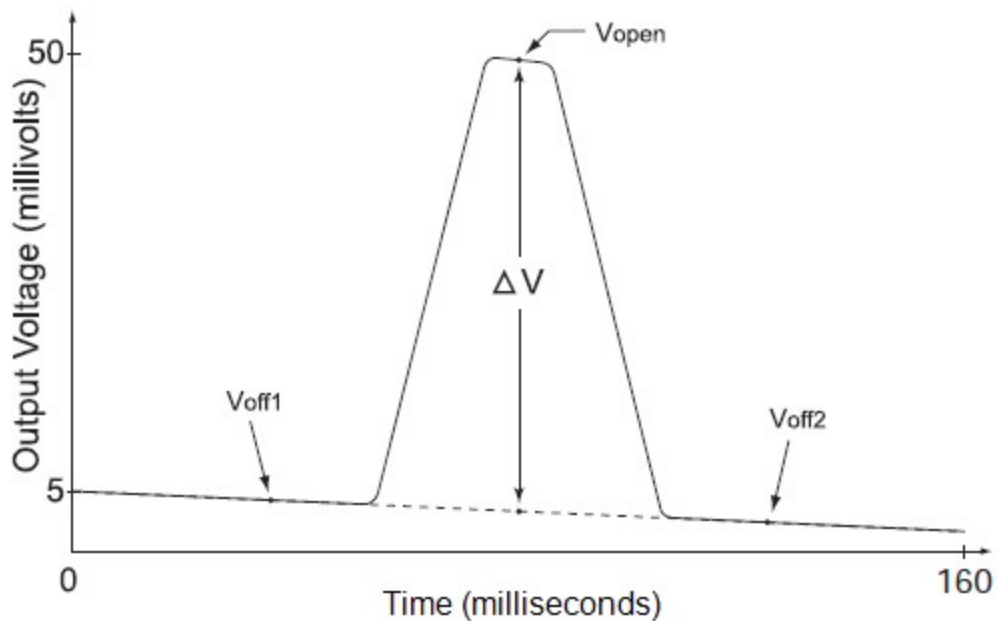

FIGURE 7-2. Charge amplifier output during an electric field measurement cycle

Offset voltages  $V_{\text{off1}}$  and  $V_{\text{off2}}$  are zero field reference measurements made when the shutter is closed, and used to accurately estimate voltage  $\Delta V$  when the shutter is completely open. Electronic offset voltages, surface potentials between various metallic parts and leakage currents on the charge amplifier input result in non-zero values of  $V_{\text{off1}}$  and  $V_{\text{off2}}$ . An electronic reset of the charge amplifier is performed prior to the measure of  $V_{\text{off1}}$  to keep the charge amplifier output near zero volts when the shutter closed. The measured electric field  $E$ , as determined from the charge amplifier output is as follows:

$$E = k\Delta V = k[V_{\text{open}} - (V_{\text{off1}} + V_{\text{off2}})/2]$$

Where  $k$  is a constant determined by electrode geometry and electronic gain. The resulting algorithm effectively eliminates measurement error sources that vary slowly with respect to the time between zero field reference measurements, which is approximately 140 ms. Measurement noise due to 50 or 60 Hz AC power can be suppressed by using the 50 Hz or 60 Hz noise rejection measurement capability of the data logger.

Current source  $I_{\text{leak}}$  in [FIGURE 7-1](#) (p. 13) represents leakage currents across the Teflon insulators supporting the sense electrode, along with the input bias current of the operational amplifier. Deleterious effects of  $I_{\text{leak}}$  are compensated for in the determination of  $\Delta V$  as given in (eq. 1). However, it is desirable to minimize the difference between  $V_{\text{off1}}$  and  $V_{\text{off2}}$  to preserve dynamic range for large magnitude  $V_{\text{open}}$  voltages. Hence a leakage-current compensation circuit is used to generate the current  $I_{\text{comp}}$  in [FIGURE 7-1](#) (p. 13) such that  $I_{\text{comp}} = I_{\text{leak}}$ . The leakage-current compensation algorithm determines  $I_{\text{comp}}$  for the present measurement based on  $I_{\text{leak}}$  from the previous measurement, which is determined as follows:

$$I_{\text{leak}} = C_f \cdot (V_{\text{off1}} - V_{\text{off2}}) / \Delta T + I_{\text{comp}}$$

Where  $C_f$  is the value of feedback capacitor used in the charge amplifier, and  $I_{\text{comp}}$  is the leakage current compensation value implemented during the measurement.

This charge amplifier input leakage current increases with degradation of insulation of the sense electrode insulators due to moisture or other surface contamination. Consequently, the measurement and reporting of  $I_{\text{leak}}$  is useful in determining if or when insulators should be cleaned.

The reciprocating motion of the CS110 electric field meter is limited to approximately 5 Hz, which is adequate for lightning hazard warning, where 1 minute averaged data is often used. The CS110 electric field measurement is a single shot measurement of the average electric field over the integration interval, with a  $\sin(x)/x$  frequency response with the first notch determined by the integration length of either  $1/(60 \text{ Hz})$  or  $1/(250 \mu\text{s})$ , depending upon the user chosen integration parameter. The resulting measured electric field is useful for applications requiring an absolute electric field measurement, such as lightning warning.

Yet when stringing multiple measurements together to look at dynamics of lightning discharges, the relatively slow CS110 maximum sample rate of 5 Hz (200 ms) imposes serious limitations. While the resulting time series presents the correct measured electric field at each measurement time, what happens between measured data points is unknown, as the shutter is closed during that time. Therefore, while good quasi-static ( $> 0.2$  s) electric field data is provided by the CS110, higher speed dynamic electric field information ( $< 0.2$  s) is not provided. For a higher speed measurements, the slow antenna mode of the CS110, as discussed in [CS110 as a slow antenna](#) (p. 59), can be used to provide 50 Hz (20 ms) electric field change data.

For applications desiring  $> 5$  Hz, the CS110 reciprocating electric field meter can be configured as a slow antenna [MacGorman and Rust 1998]. The shutter would typically be left open indefinitely in slow antenna mode and resistor R3, depicted in [FIGURE 7-1](#) (p. 13), is switched in parallel with Cf providing a 66 ms decay time constant for the charge amplifier. In the slow antenna mode, the charge amplifier has a high-pass filter frequency response with the lower cutoff frequency defined as  $f_{3\text{ dB}} = (2\pi RC)^{-1} = 2.4$  Hz. In this mode, the instrument is a field change meter and the charge amplifier output can be sampled by the data logger as fast as every 20 ms (50 Hz), using 250  $\mu\text{s}$  integration durations for the analog integrator. Voltage measurements using the 250  $\mu\text{s}$  integration duration for an analog integrator, result in an upper 3 dB bandwidth of 1.8 kHz. Refer to [CS110 as a slow antenna](#) (p. 59) for detailed information about the slow antenna mode.

## 7.2 CS110 lightning detection example

The following figure illustrates the atmospheric electric field monitored by a CS110 during a local thunderstorm. In this figure, the atmospheric electric field changes dramatically from fair weather conditions (approximately -100 V/m) during this thunderstorm. The abrupt electric field change observed at approximately 6:12 A.M. was due to a hazardous cloud-to-ground lightning discharge. As the electric field is seen to deviate from a typical fair-weather field and approach levels capable of producing hazardous lightning discharges, a lightning hazard warning algorithm would ideally issue an alarm, or perhaps various caution/alarm levels, during the critical front-end portion of the storm illustrated here.

There is no universal hazard alarm level based on atmospheric electric field, although two levels that have been used are  $\geq 1000$  V/m [LPLWS] and  $\geq 2000$  V/m [NAVSEA]. The lower the level used, the greater reduction of risk, but this is at the expense of increased downtime for operations suspended for lightning hazard warning.

### **WARNING:**

Campbell Scientific is not liable for the reliability and performance of the warning algorithms implemented by users of our equipment. While lightning warning systems can greatly reduce

the probability of death or injury from lightning discharges, they cannot reduce this probability to zero.

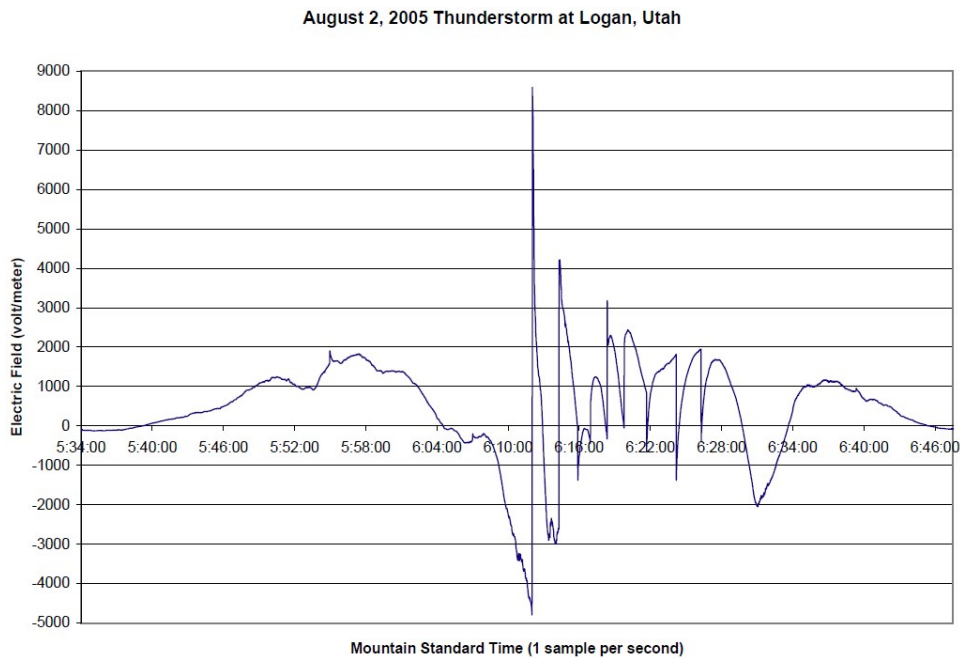

## 7.3 Lightning warning levels

The EFM measures electric field (efield) from -25,000 to +25,000 V/m. The EFM one-second measurement of the electric field allows it to detect both cloud-to-ground and cloud-to-cloud lightning strikes within a 25-mile radius. Lightning strike detection efficiency is 95% when within 5 miles, 93% when within 10 miles, and 68% when within 20 miles.

The optional SG000 measures lightning strikes and their approximate distance broken down into close (0 to 5 miles), near (0 to 10 miles), or distant (0 to 20 miles).

### **DANGER:**

**Lightning safety guidelines based on human observations should not be ignored simply because of the presence of sensitive electronic instrumentation.** The NOAA 30/30 rule suggests seeking shelter if thunder is heard within 30 seconds of a lightning flash (a distance of approximately 6 miles), and remaining in a sheltered area for 30 minutes after the last lightning or thunder before resuming outdoor activities.

### **DANGER:**

**No method of lightning warning completely eliminates the risks associated with lightning.** Lightning detectors give no warning until a detectable discharge has occurred. Atmospheric

electric field meters give warning prior to the first strike for storms developing overhead, along with some indication of the end of a thunderstorm. However, there are occurrences of cloud-to-ground lightning discharges striking the ground several miles from the electrified cloud where the discharge originated [NOAA]. Electric field monitors may give no practical warning in these instances because the electric field in the vicinity of the strike point may not indicate hazardous levels until milliseconds before the strike. Consequently, **while lightning warning systems can greatly reduce the probability of death or injury from lightning discharges, they cannot reduce this probability to zero.**

## 7.3.1 All Clear

The All Clear state indicates all of the following:

- The one- and ten-minute running averages of the electric field are both less than  $|\pm 500$  V/m|.
- There have been no lightning strikes in the last 30 minutes.
- If used, the SG000 shows no close (0 to 5 mi) or near (0 to 10 mi) strikes in the last 30 minutes.

At the All Clear state, RTMC display software shows **No Lightning Strikes** (SG000 option only) and **Low E\_Field**.

The blue light flashes on RA100 remote alarms.

## 7.3.2 Caution or Lightning Watch

The Caution or Lightning Watch state indicates any of the following:

- The one-minute running average of the electric field is greater than  $|\pm 1000$  V/m|.
- There are two or more lightning flashes within a 25-mile radius in a 5-minute period.
- The SG000 shows distant (0 to 20 mi) strikes.

To return to a Caution state from an Alarm state, the following must occur:

- The one- and ten-minute running averages of the electric field must both be less than  $|\pm 1000$  V/m|.
- The SG000 must show no close (0 to 5 mi) or near (0 to 10 mi) strikes in the last 30 minutes.

At the Caution state, display software shows **E\_FIELD CAUTION** or **LIGHTNING STRIKE CAUTION**.

The yellow light flashes on RA100 remote alarms.

### 7.3.3 Alarm or Lightning Warning

The Alarm or Lightning Warning state indicates any of the following:

- The one-minute running average of the electric field is greater than  $|\pm 2000 \text{ V/m}|$ .
- The SG000 shows close (0 to 5 mi) or near (0 to 10 mi) strikes.

At the Alarm state, display software shows **E\_FIELD ALARM** or **LIGHTNING STRIKE ALARM**.

The red light flashes on RA100 remote alarms, and the siren sounds for 3 seconds every 2 minutes if within the start and stop times.

State	RA100 strobe color	Description
All Clear	Blue	All of the following conditions are met: <ul style="list-style-type: none"> <li>• 1- and 10-minute running averages of the electric field are less than <math> \pm 500 \text{ V/m} </math>.</li> <li>• No lightning strikes in the last 30 minutes.</li> </ul>
Caution or Lightning Watch	Yellow	The CS110 enters a <b>Caution</b> state from the <b>All Clear</b> state when either of the following conditions are met: <ul style="list-style-type: none"> <li>• 1-minute running average of the electric field is greater than <math> \pm 1000 \text{ V/m} </math>.</li> <li>• 2 or more lightning strikes within a 25-mile radius in a 5-minute period.</li> <li>• SG000 detects distant (0 to 20 mile) strikes.</li> </ul> The CS110 enters a Caution state from the Alarm state when both of the following conditions are met: <ul style="list-style-type: none"> <li>• 1- and 10-minute running averages of the electric field are less than <math> \pm 1000 \text{ V/m} </math>.</li> <li>• No close (0 to 5 mile) nor near (0 to 10 mile) strikes in the last 30 minutes.</li> </ul>
Alarm or Lightning Warning	Red	The CS110 enters an <b>Alarm</b> state from the <b>Caution</b> state when either of the following conditions are met: <ul style="list-style-type: none"> <li>• 1-minute running average of the electric field is greater than <math> \pm 2000 \text{ V/m} </math>.</li> <li>• SG000 shows close (0 to 5 mile) or near (0 to 10 mile) strikes.</li> </ul>

## 7.4 Factory calibration of the CS110

Electric field meters are typically factory calibrated using a parallel plate method, where a uniform electric field is developed by applying a known voltage between parallel conductive plates. The large hexagonal parallel plate electric field calibrator illustrated below is used in the factory calibration of the CS110 Electric Field Meter.

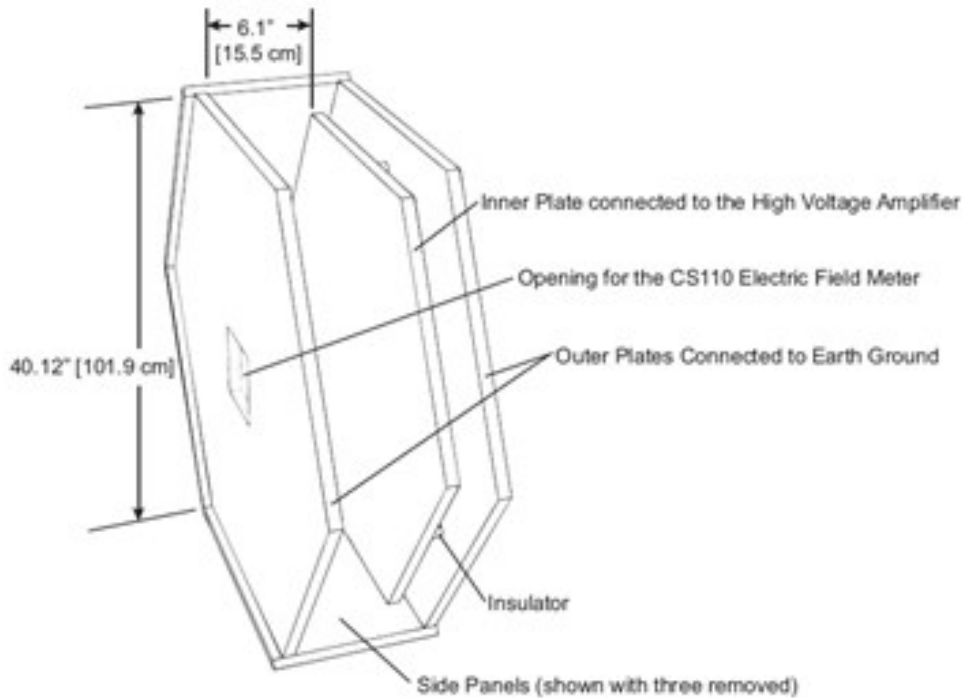

The large physical size was incorporated to minimize non-ideal fringing effects. Sharp corners were avoided in order to prevent corona discharge. All metal parts of the calibrator are manufactured from stainless steel. The inside surfaces are polished to reduce the surface charges in order to provide a stable zero electric field. All outer surfaces are electronically connected and tied to earth ground, while the insulated inner plate is driven by a high-voltage amplifier. The high-voltage amplifier is calibrated annually against a reference that is traceable to the National Institute of Standards and Technology (NIST).

Each CS110 is factory calibrated in the parallel-plate calibration fixture shown. A linear fit of the calibration data results in a calibration equation in slope-intercept form expressed as

$$E = M_{\text{parallel\_plate}} \times V + O_{\text{parallel\_plate}}$$

The multiplier  $M_{\text{parallel\_plate}}$  is a function of the CS110 electrode dimensions and the feedback capacitor in the charge amplifier. The offset term  $O_{\text{parallel\_plate}}$  is due to unwanted surface charges residing on non-conductive deposits on the electrodes.

The electric field offset of an instrument varies over time because of variations in surface cleanliness as well as charging and discharging processes. Polished 316-L stainless steel is used

for critical electrode surfaces on the CS110 to minimize unwanted surface charges. CS110s with clean electrodes have been found to display electric field offsets less than 30 V/m, which has negligible effect on the determination of  $M_{\text{parallel\_plate}}$  because of the  $\pm 15000$  V/m range of electric fields used during factory calibration. Neglecting  $O_{\text{parallel\_plate}}$  results in the simplified parallel-plate calibration equation

$$E = M_{\text{parallel\_plate}} \times V$$

The estimated measurement accuracy of  $M_{\text{parallel\_plate}}$  for the CS110 calibrated in the parallel plate electric field calibrator shown is  $\pm 1\%$ . The electric field offset of the CS110 can be measured by covering the stator with a clean Zero Electric Field Cover. If the resulting zero field reading with the zero field cover exceeds  $|\pm 60 \text{ V/m} \times C_{\text{site}}|$ , then clean the electrodes of the CS110. For example, if the typical  $C_{\text{site}}$  is 0.1, then clean the electrodes if the zero reading exceeds  $|6 \text{ V/m}|$

The factory calibration data for a typical CS110 calibration and resulting determination of  $M_{\text{parallel\_plate}} = 84.32 \text{ V/m} \times \text{mV}$  is shown in the following figure.

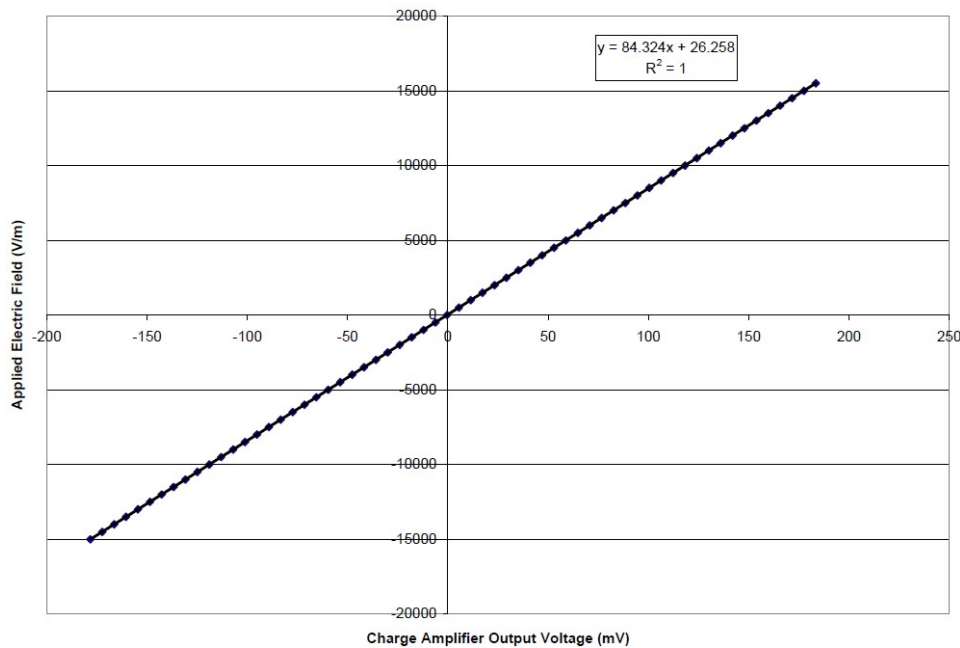



A calibration certificate is sent with each CS110.



### Certificate of Calibration

**Model:** CS110 - L  
**CS110 Serial Number:** 1172  
**CR1000 Serial Number:** 25836  
**Calibration Procedure:** TST16058B 04  
**Instrument Calibration Condition:** In Tolerance  
**Calibration Date:** 7/14/2009

**Calibration Standards Used:**

Model: Trek 609E-6-L-CE  
S/N: 212  
Cal. Due Date: 3/16/2010  
NIST Reference: 263994

**Instrument Data:** Multiplier = 85.75 R Squared Value = 1

**Environment** Temperature (C) 25 Relative Humidity (%) 10.5

**Calibration By:** W. Iverson  
W. Iverson

Campbell Scientific, Inc. certifies the above instrument meets or exceeds published specifications and has been calibrated using a Voltage Standard whose gain accuracy is traceable to the National Institute of Standards and Technology. Electrostatic field measurements are not NIST Traceable. Refer to the CS110 Operators manual for more information. The policies and procedures at this calibration facility comply with ISO-9001.

#### NOTE:

Careful removal and replacement of the stator on the CS110 does not invalidate the factory-derived  $M_{\text{parallel\_plate}}$  value of a given unit. However, switching stators with another unit or bending the stator, shutter, or sense electrodes invalidates the factory parallel-plate calibration because of possible electrode dimension changes.

## 7.5 Site correction

Each CS110 is factory calibrated in a parallel plate calibration fixture, resulting in the calibration equation  $E = M_{\text{parallel\_plate}} \cdot V$ . However, when monitoring the Earth's electric field, this equation is valid only if the instrument aperture is mounted flush with the Earth's surface and facing upward. Yet, for permanent outdoor measurements of electric field, a flush-mounted and upward-facing orientation is problematic because of dirt, rain, bird droppings, debris, etc., collecting on the sense electrodes and fouling the measurement. Consequently, a downward-facing and elevated configuration is recommended for long-term field applications, as illustrated in the following image.

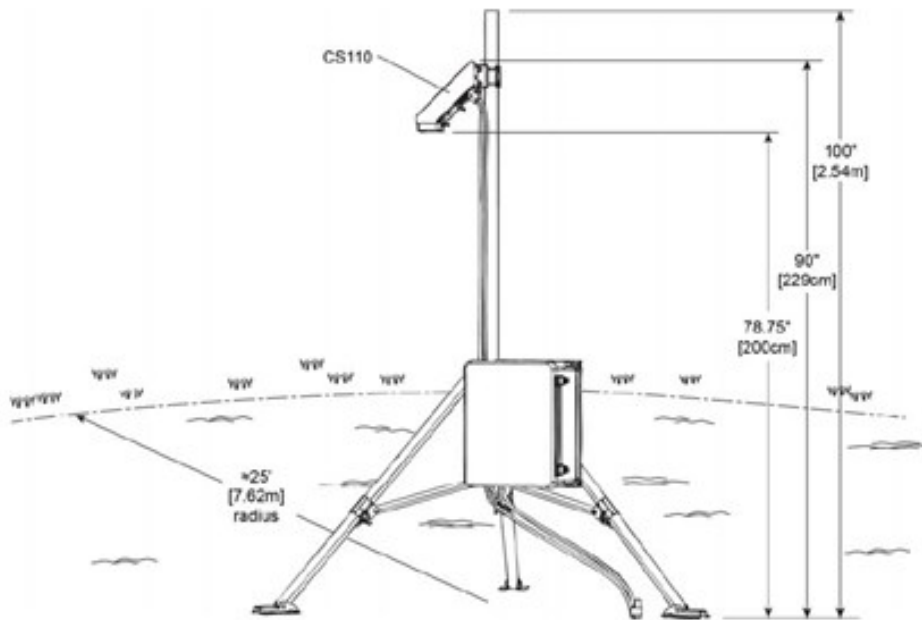

Inverting the CS110 reduces the effective gain, while elevating its height above ground enhances the gain, with respect to an ideal upward-facing, flush-mounted geometry. It should be mentioned that this gain enhancement reduces the effect of unwanted electrical field offsets. A site correction factor,  $C_{\text{site}}$ , is necessary to correct  $M_{\text{parallel\_plate}}$  for non-flush-mounted configurations [McGorman and Rust]. The corrected multiplier  $M_{\text{corrected}}$  becomes

$$M_{\text{corrected}} = C_{\text{site}} \cdot M_{\text{parallel\_plate}}$$

In this equation,  $M_{\text{parallel\_plate}}$  is unique for each CS110, yet independent of a given site, whereas  $C_{\text{site}}$  is unique for each given site, yet independent of the particular CS110 used at the site.  $C_{\text{site}}$  is typically determined by using a flush-mounted, upward-facing unit in the vicinity of the site needing correction. Campbell Scientific, Inc developed a site correction facility to determine  $C_{\text{site}}$  for various site configurations.

An upward-facing calibration kit was developed to hold the CS110 in a flush-mounted, upward facing position.

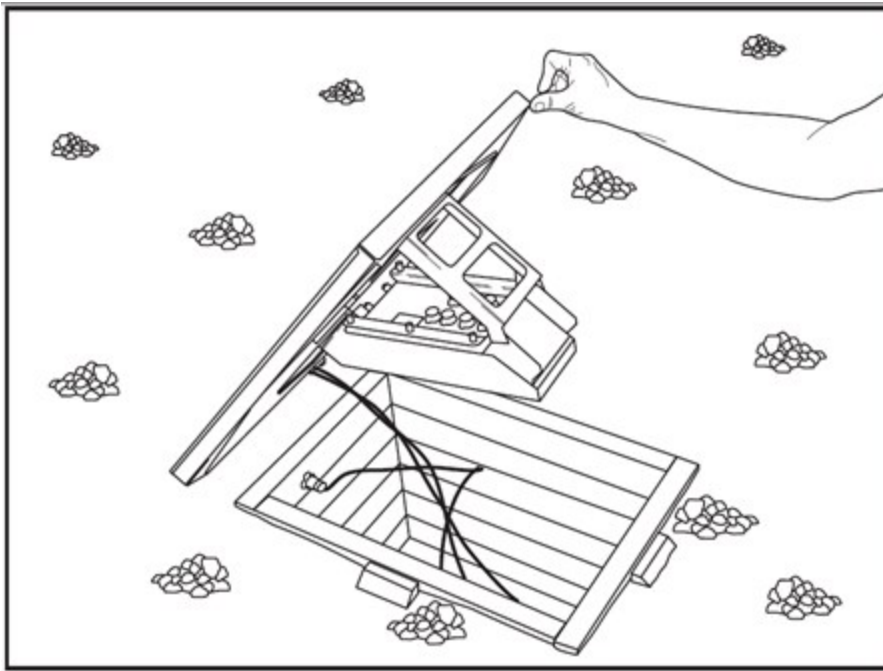

**NOTE:**

Both the upward-facing and the inverted and elevated unit need to be electrically connected to earth ground. This can best be accomplished with a grounding rod and wire connected to ground lugs provided on both the upward-facing plate and on the mounting bracket on the standard CS110.

Ideally, site correction should be done in the absence of precipitation and during the presence of slowly varying and bipolar electric fields with magnitudes large enough to make instrument offset errors negligible. These conditions may be infrequent in practice, making site correction using a flush-mounted, upward-facing unit challenging. Precipitation and blowing dirt can result in questionable measurements by an exposed, upward-facing unit. The electrodes of an upward-facing unit should be cleaned after it has been exposed to blowing dust and/or precipitation.

The measurement of meteorological parameters such as rainfall, along with the averaging and data storage capability of the CS110 can be used to autonomously measure, process, and store data to aid in site correction.

Campbell Scientific has performed a site correction on a CS110 2-Meter CM110 Tripod Site. The collected data between an upward-facing unit and a downward facing CS110 2-Meter CM110 Tripod site is illustrated in the following graph. A best-fit line computed from the data resulted in  $C_{\text{site}} = 0.105 \pm 4\%$ , which is valid for users at other sites who use the same site dimensions on level terrain clear of vegetation.

10/02/05 Site Correction of CS110 2 Meter CM110 Tripod Site  
Results indicate Csite = 0.105.

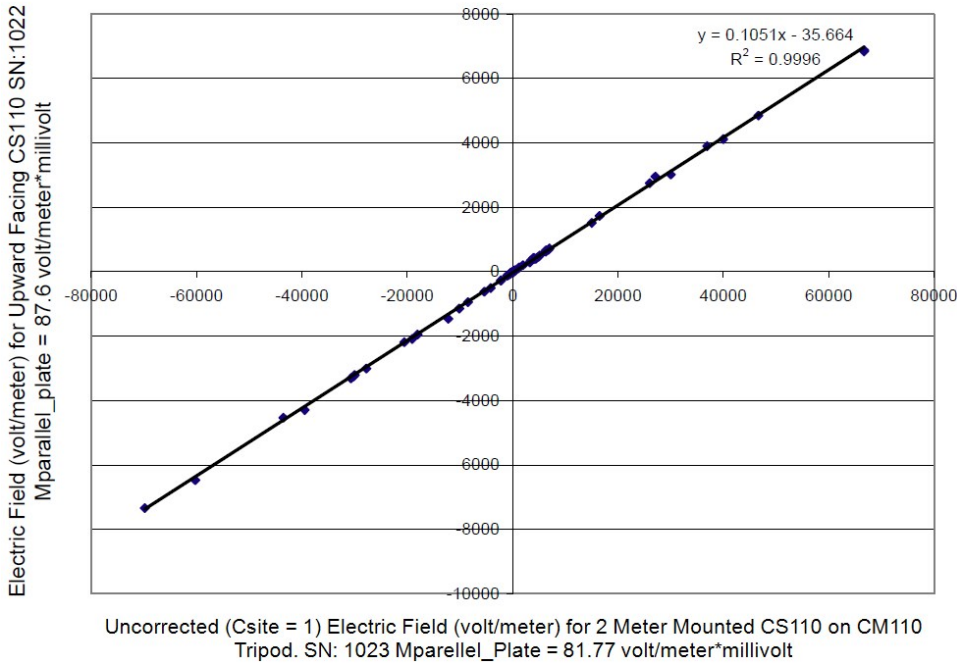

**NOTE:**

The user is responsible for determining if a CS110 site is representative of the CS110 2-Meter CM110 Tripod site, and if not, for determining the appropriate site correction.

The atmospheric electric field at the Earth's surface during fair-weather conditions is on the order of -100 V/m; the negative sign indicating that the electrostatic force on a positive charge is directed downward toward the Earth's surface [McGorman and Rust], [Rakov and Uman]. Generic site corrections are sometimes computed in fair-weather conditions by assuming a -100 V/m fair-weather field. The accuracy of a fair-weather site correction is questionable because local conditions may result in a fair-weather field significantly different (>100%) from -100 V/m. Also, the unknown electric field offset may be significant when calibrating at -100 V/m. This offset can be measured by covering the stator with a clean Zero Electric Field Cover.

**NOTE:**

Fair-weather field site correction is not recommended for lightning warning applications because of the relatively poor accuracy in determining  $C_{site}$ .

# 8. CS110 maintenance

The CS110 has been designed to provide reliable electric field measurements and to simplify and minimize maintenance. To identify measurement problems and reduce or eliminate scheduled maintenance, the CS110 incorporates extensive self-checking and status information with each measurement.

## 8.1 Status codes

The status code returned with each electric field measurement reports on instrument health and any measurement errors. Status codes are returned in the **Public** variable table.

An example CS110 instruction follows.

```
CS110(E_field,leakage_cur,status,_60Hz,Mu1t,Offset)
```

Returned **E\_field** values of NAN (not a number) indicate a measurement problem that can be determined from the associated status code.

Status code	Meaning
1	Good instrument health. $\pm 250$ mV measurement range only. Return measured $E_{\text{field}}$ value.
2	Good instrument health. $\pm 2500$ mV measurement range used. Return measured $E_{\text{field}}$ value.
3	Good instrument health. NAN returned for Efield because of measurement overrange on the $\pm 2500$ mV measurement range.
4	Good instrument health. $\pm 250$ mV measurement range only. Had to properly position shutter.
5	Good instrument health. $\pm 2500$ mV measurement range used. Had to properly position shutter.
6	Good instrument health. NAN returned for $E_{\text{field}}$ because of measurement overrange on the $\pm 2500$ mB measurement range. Had to properly position shutter.
7	+5V ext low. Return measured $E_{\text{field}}$ value.
8	Data logger skipped scan. Return measured $E_{\text{field}}$ value.

Table 8-1: Status codes	
Status code	Meaning
9	Input power < 9.6 V. Return measured $E_{\text{field}}$ value.
10	Data logger watchdog reset. Return measured $E_{\text{field}}$ value.
11	Leakage current exceeds compensation range of $\pm 4.2$ nA. Return measured $E_{\text{field}}$ value.
12	Failed charge-amplifier self check. Return NAN instead of measured $E_{\text{field}}$ value.
13	Large closed shutter offset voltage. $V_{\text{os}} >  1.00 \text{ V} $ . Return NAN instead of measured $E_{\text{field}}$ value.
14	Motor move error. Incorrect number of motor steps to close shutter. Return NAN instead of measured $E_{\text{field}}$ value.
15	Motor move error. Encoder UPCNTs < 24 or > 26. Encoder DNCNTs < 24 or > 26, or don't find come when closing. Return NAN instead of measured $E_{\text{field}}$ value.
16	Can't properly position shutter. Return NAN instead of measured $E_{\text{field}}$ value.
17	CS110 internal RH reading is > 60%. Desiccant change is needed. Refer to <a href="#">Changing desiccant</a> (p. 27)

No priority issues exist with status codes 1 through 3 since only one of these codes can occur per measurement.

Status codes 4 through 6 indicate the shutter was not properly positioned when the measurement started, and the problem was recognized, corrected, and a valid measurement made. Status codes 4 through 6 are common upon power up or if the shutter has been touched or bumped since the last measurement of  $E_{\text{field}}$ . Persisting status codes 4 through 6 indicate a problem with parking the shutter that should be investigated.

Status codes 7 through 10 increase in priority with 7 being the lowest priority and 10 being the highest priority. Status code 7 is a low priority error message, because low +5  $V_{\text{ext}}$  does not corrupt electric field measurements. Status code 7 is overwritten by other warning and error codes (status code > 7).

Status codes 8 through 10 are the highest priority error messages returned by the CS110 and will overwrite lesser errors that occur simultaneously during the  $E_{\text{field}}$  measurement. Since only one status value can be returned for each measurement, status 10 is given the highest priority, status 9

the second highest, and 8 the third highest priority. Next in priority are codes 16, 15, 14, 13, 12, and 11, followed by 7, 6, 5, 4, 3, 2, and 1.

Status code 11 returns the measured  $E_{\text{field}}$  value because the electric field computation algorithm compensates for leakage current, even if it exceeds  $\pm 4.2$  nA, although maximum signal amplitude becomes limited. Prolonged leakage current values near to and exceeding  $|\pm 4.2$  nA are likely due to insulator contamination, requiring removal of the stator and cleaning.

Status codes 12 through 16 all cause the measured electric field to be set to NAN to prevent the use of possible erroneous measurements. The priority of codes 11 through 16 increases with increasing values, although codes 8, 9, and 10 are higher priority.

## 8.2 Changing desiccant

The CS110 contains desiccant inside the sealed case to reduce humidity for the sensitive electronics enclosed. A relative humidity sensor is included inside the CS110 case to provide information on when case desiccant should be changed. The relative humidity measurement is reported in the `EFM_internal_RH_percent` variable in the **Public** table.

For best operation, change CS110 desiccant when the average internal relative humidity values are  $> 20\%$ .

How to change the desiccant in the CS110:

1. Remove the CS110 case lid by unscrewing the captive screws that attach the lid to the main body of the CS110.
2. Inspect the gasket on the CS110 lid to make sure that a good seal is possible when the lid is replaced.
3. Remove the old desiccant pack and replace with a new 4 unit desiccant pack, making sure the new pack is placed into the bracket that prevents the desiccant from sliding into the motor assembly.

If the sealed CS110 case requires replacing desiccant at intervals less than once every six months, it indicates a problem with the CS110 case seal or with the desiccant packs being used.

Status code 17 indicates that humidity inside the CS110 has reached a critical level and desiccant needs to be changed. For best operation, the desiccant should be changed when RH exceeds 20%, while status code 17 warns that RH has exceeded 3 times that value.

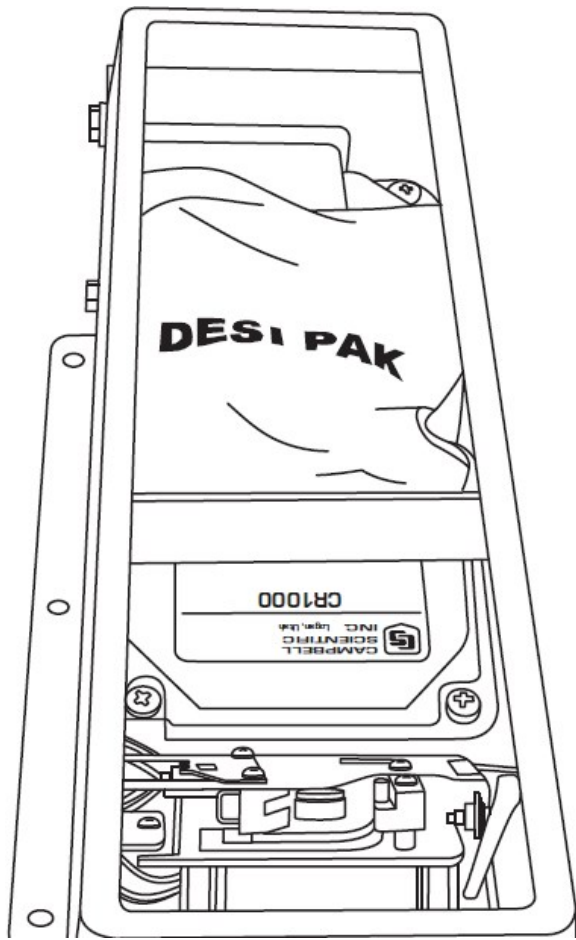

## 8.3 Cleaning the CS110 electrode head

The CS110 motor assembly illustrating the 316-L stainless-steel stator, shutter, and sense electrode is illustrated in the following figure.



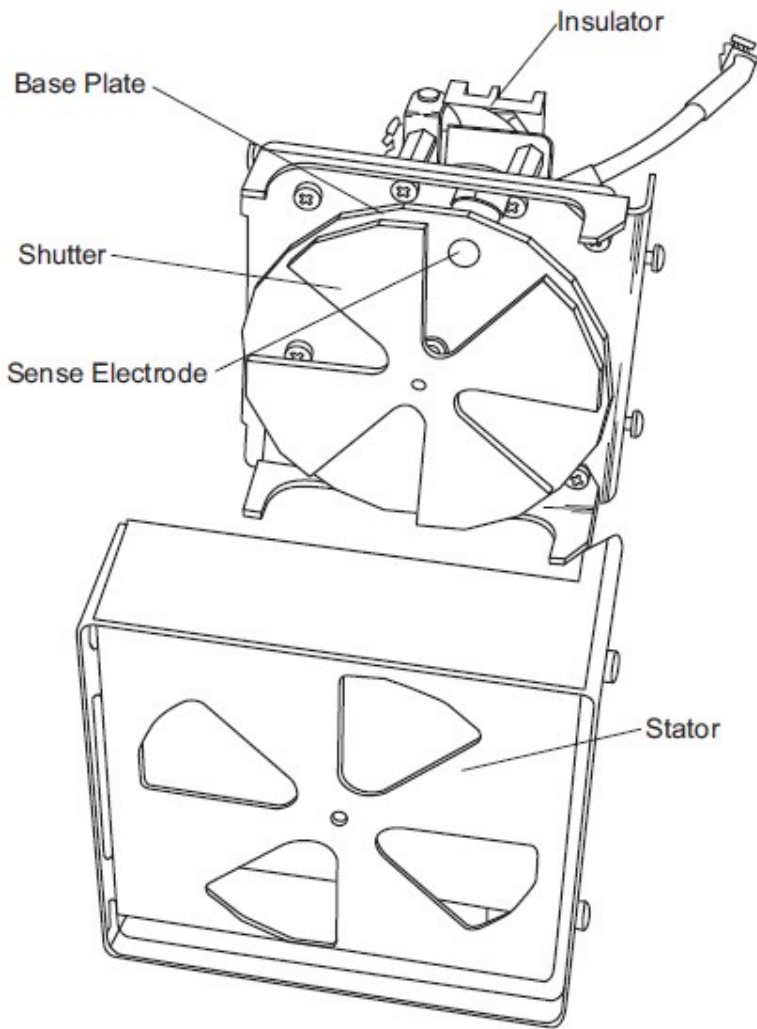

Contamination of the polished stator, shutter, or sense electrode can result in unwanted surface charges that induce offset errors in the electric field measurement.

Three Teflon insulators electrically insulate the high-impedance sense electrode from the motor assembly base plate. Surface contamination of these insulators can result in excessive leakage current. The CS110 includes a circuit to compensate for input leakage current on the charge amplifier up to  $\pm 4.2$  nA. Leakage current values in excess of  $\pm 4.2$  nA can cause measurement errors and are indicated by status code 11.

Clean the CS110 electrodes and/or insulators if any of the following conditions occur:

- Insulators are dry and leakage current exceeds  $\pm 4.2$  nA as indicated by code 11.
- Visual evidence of contamination (salt deposits, scaling, dust, spider webs etc.) on or around electrode area.

- Zero field reading with Zero Electric Field Cover exceeds 60 V/m.

**NOTE:**

For good zero field readings, it is important that the inside of the zero field cover also be clean.

How to clean the CS110 electrode head:

1. Remove the stator by loosening the two Phillips head screws on the motor assembly base plate, allowing the stator to pivot and be removed.
2. Inspect the stator for any contaminant deposits and scrub such deposits off with soap and hot water. Any residue may form nonconductive layers that can hold unwanted surface charge. Using a brush that will fit between the shutter and the sense electrode, carefully wash the shutter and sense electrode, along with the three insulators attaching the sense electrode to the main body of the CS110. One brush ships with each CS110. Large offsets are likely due to electrical charges residing insulative on deposits on metallic surfaces, while large leakage currents are likely due to contaminated insulators.
3. Rinse well with deionized water and blow dry with air. Rubbing and wiping tends to induce unwanted surface charging that will eventually dissipate.
4. Reassemble the stator, making sure it is positioned properly before tightening the two Philips head stator screws. Avoid getting fingerprints, etc., on clean electrodes as they can result in unwanted surface charge. (Clean cotton gloves are helpful.)
5. Attach the Zero Electric Field Cover to the stator and verify that the leakage current is  $< |0.5 \text{ nA}|$  and that the zero field offset is  $< 60 \text{ V/m}$ . Leakage current  $> |0.5 \text{ nA}|$  and/or zero field offsets  $> 60 \text{ V/m}$  indicate problems with cleanliness and/or unwanted surface charge.

## 8.4 Checking ground integrity

The CS110 electric field meter needs to be electrically connected to earth ground for valid measurements. For optimum operation, periodically check the integrity of this earth ground connection by verifying that the resistance of the stator to grounding rod is  $< 1 \Omega$ .

## 8.5 Protecting from corrosion and rust

In corrosive environments, metal friction points (set screws, bolts, etc.) and electrical connections to earth ground can be protected with the use of a rust inhibitor. Use the Loctite shipped with the CS110 to lubricate all threaded screws to prevent corrosion and seizing.

## 8.6 Recalibration

Recalibration of instruments is commonly done in data-critical applications to combat component drift with time. Component drift is a function of the environment experienced by the instrument. High-humidity and/or high-temperature environments generally cause the most drift.

The embedded CR1000M data logger module should experience a low-humidity environment, which helps minimize data logger measurement drift. While measurement drift of the CR1000M is likely negligible with regard to the  $\pm 5\%$  of reading accuracy specification of electric field measurements, the CR1000M drift may be a factor for the temperature measurement by means of the external temperature and RH probe.

### NOTE:

The CR1000 measurement accuracy is negligible in the overall CS110 accuracy, which is limited by the charge amplifier circuit and mechanical dimensions of the shutter, stator, and sense electrode. Therefore, the CS110 accuracy specification remains valid after replacing or recalibrating the CR1000.

Each CS110 is factory calibrated in the parallel plate calibrator to determine individual instrument gain (see [Factory calibration of the CS110](#) (p. 19)). The CS110 electric field measurement instrument gain is a function of electrode dimensions, along with the 1% feedback capacitor used in the charge amplifier.

A parallel-plate calibration is recommended whenever any electrodes are bent, removed, or replaced, with the exception of the removal and replacement of the same stator during the process of insulator cleaning. For applications requiring long-term electric field measurement accuracy better than  $\pm 10\%$ , a parallel plate factory calibration is recommended every 3 years.

The expected lifetime of the CS110 is 5 to 10 years, again depending upon the operational environment. Instruments operated in coastal environments will likely suffer from external finish degradation and/or operational failure sooner than instruments operated in dry inland environments.

## 8.7 Troubleshooting

Repeated Status code 12s when the CS110 is clean may be solved by replacing the capacitor.

The operating system does a charge amplifier self-check which involves exercising the charge amplifier by means of applying a known voltage change to the charge amplifier input using 4.7 pf capacitor C58. The output limits for the measured voltage were determined empirically by characterizing some typical units, then adding  $\pm 10\%$  to the average or typical value. The intent

was to prevent an unstable charge amplifier from providing incorrect measured data. The critical components in the charge amplifier performance are the TLC2201 (10599) op-amp, the 330 pf capacitor C59, and probably the 4.7 pf capacitor C58. Leaky relays or leakage due to residual flux could also cause problems with the charge amplifier as it is a very high impedance input circuit.

## 9. References

---

"Lightning Physics and Effects" by Vladimir A. Rakov and Martin A. Uman, Cambridge University Press, 2003.

"The Electrical Nature of Storms" by Donald R. MacGorman, and W. David Rust, Oxford University Press, Inc., 1998.

"On some determinations of the sign and magnitude of electric discharges in lightning flashes" by C.T.R. Wilson, Proceedings of the Royal Society, Series A, Vol. 92, 555-574, 1916.

"Industrial Electrostatics – fundamentals and measurements" by D.M. Taylor and P.E. Secker, John Wiley & Sons Inc. 1994, pg. 36-38.

[LPLWS] "LPLWWS handbook" by NASA, April 2003

NAVSEA OP 5, Vol 1, Seventh Rev. Para 6-2, pg 6-1 and 6-2, 2001.

OSHA NOAA Fact Sheet: Lightning Safety When Working Outdoors

<http://elcosh.org/document/4154/d001459/osha-noaa-fact-sheet%3A-lightning-safetywhen-working-outdoors.html>

Swenson; Jody A., Beasley; William H., Byerley; Leon G., Bogoev; Ivan G. Electric-field meter having current compensation. U.S. Patent No. 7,109,698, filed March 25, 2004 and issued September 19, 2006

# Appendix A. Connector pin-outs

---

FIGURE A-1 (p. 33) shows the numbering for the connectors from the solder-cup side of the cabled connector. The circular connectors are Mini-Con-X type from Conxall. Campbell Scientific fills the backshell of the connector with a relatively thick epoxy to seal and provide strain relief.

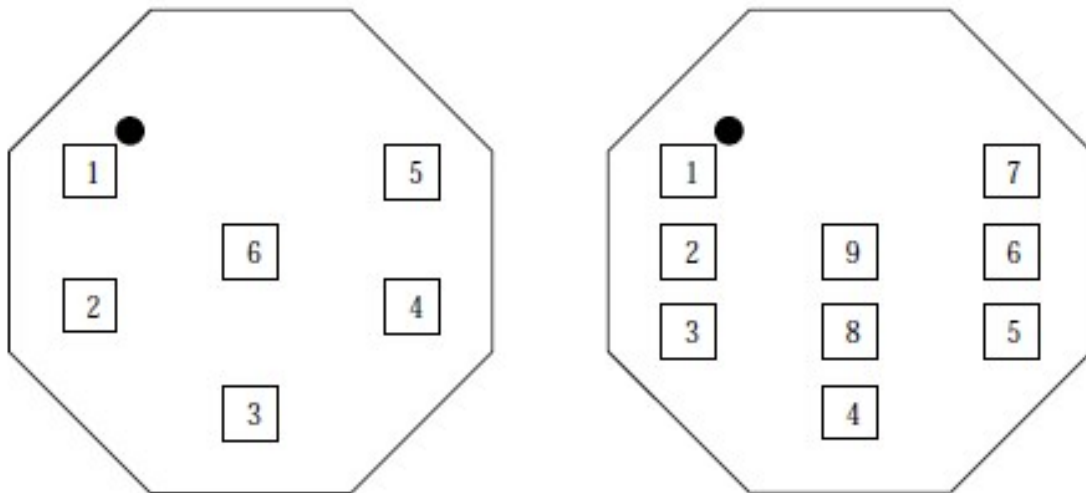

FIGURE A-1. Pin numbers for 6-pin and 9-pin connectors

## A.1 Sensor connectors

The corresponding terminals listed in the tables are needed for programming the sensors.

## RAIN connector

This connector is for measuring a tipping bucket rain gage such as the TE525.

Pin number	CR1000 terminal
1	empty
2	empty
3	<b>P2</b>
empty	empty
5	⊥ (analog ground)
6	⊥ (analog ground)

## WIND connector

This connector is for measuring a wind speed and direction sensor such as the 05103-L-C Wind Monitor.

Pin number	CR1000 terminal
1	<b>SE4</b> (also connects to ground via a 1 Mohm 1% 50ppm resistor)
2	⊥ (analog ground)
3	<b>VX2</b>
4	<b>P1</b>
5	<b>G</b> (power ground)
6	⊥ (analog ground)

### Temp/RH connector

This connector is for measuring a temperature and relative humidity sensor such as the EE181 or HMP60 sensor.

Table A-3: TEMP/RH connector pin number and CR1000 connection	
Pin number	CR1000 terminal
1	SE1 or 1H
2	SE2 or 1L (also connects to ground via a 1 Kohm 0.1% 10 ppm/C resistor)
3	empty
4	SW12V
5	⊥ (analog ground)
6	G (power ground)

### SOLAR connector

This connector is for measuring a pyranometer, barometer, or GPSX16-HVS GPS receiver. The barometer attaches to this connector using the Barometric Pressure Sensor Cable and must be housed in a separate enclosure such as the ENC100.

Table A-4: SOLAR connector pin number and CR1000 connection	
Pin number	CR1000 terminal
1	SE5 or 3H
2	SE6 or 3L (also connects to ground via a 1 Kohm 0.1% 10 ppm/C resistor)
3	empty
4	SW12V
5	⊥ (analog ground)
6	G (power ground)

## A.2 Power and communications connectors

### POWERconnector

The CS110CBL3-L CS110 Power Cable includes a female connector that mates with the CS110 POWER connector and pigtails that connect with the power supply or an additional data logger.

Pin number	Power supply or data logger terminal	CS110CBL3-L wire color
1	C1 (control terminal 1)	Blue <sup>1</sup>
2	+12V (+ power)	Red
3	G or $\perp$ (shield, analog ground)	Clear
4	G or $\perp$ (power ground)	Black
5	C3 (control terminal 3)	Green <sup>1</sup>
6	C2 (control terminal 2)	Yellow <sup>1</sup>

<sup>1</sup> Control terminals are connecting an additional data logger and are not used when connecting the CS110CBL3-L to a power supply.



## CS I/O connector

The CS110CBL2-L includes a military connector that attaches to the CS110 **CS I/O** connector and a 9-pin connector that attaches to a communications device such as the NL241.

Pin number	Description
1	+5 VDC supply
2	Power ground
3	Ring
4	Receive
5	Modem enable
6	Synchronous device enable
7	Clock hand shake
8	+12 VDC
9	Transmit

## RS-232 connector

The CS110CBL1-L includes a military connector that attaches to the CS110 **RS-232** connector and a 9-pin connector that attaches to FC100 fiber optic converter.

Pin number	Description
1	Data terminal ready
2	Transmit
3	Receive
4	empty
5	Power ground
6	Tied to pin 1
7	Clear to send
8	Request to send
9	Ring

# Appendix B. Installing a CM106B tripod

---

Contact local utility providers to locate any buried utilities prior to installation. Assemble the tripod so that the top is 2.54 m (100 inches) from the ground.

First, prepare the area where the tripod will be installed. The tripod requires an area approximately 2.7 to 3.5 m (8.7 to 11.5 ft) in diameter. See [Site selection](#) (p. 7). Next, using a sledge hammer or fence post driver, drive the grounding rod into the ground where the center of the tripod is to be located.

## B.1 Tripod base

1. Stand the tripod base up on end and rotate the feet perpendicular to the legs.
2. Each leg has a leg clamp and clamping bolt as shown in the following image. Loosen the tension bolt and extend each leg.

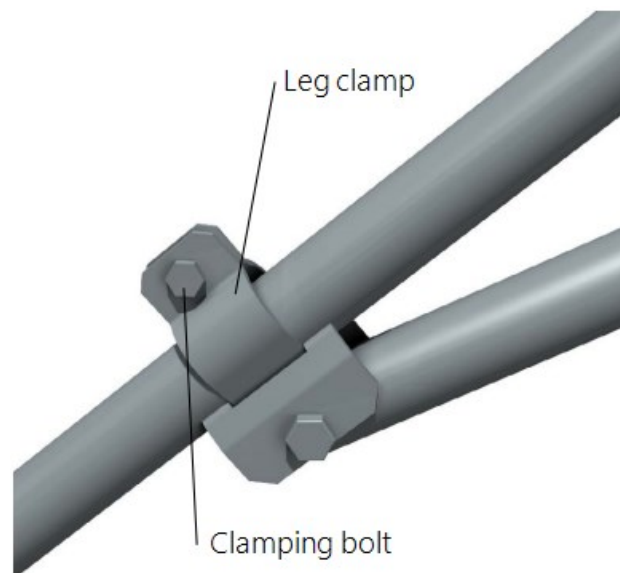

*FIGURE B-1. Tripod leg, leg clamp components*

3. Center the tripod base over the installed grounding rod.

4. If a solar panel is being used, orient the tripod with one of the legs pointing toward the equator and install the solar panel on that leg.

The tripod is typically plumbed after the mast has been installed.

## B.2 Staking tripod feet

Six stakes are provided for securing the tripod feet to the ground. Drive two stakes through holes in each foot at an angle as shown in the following image.

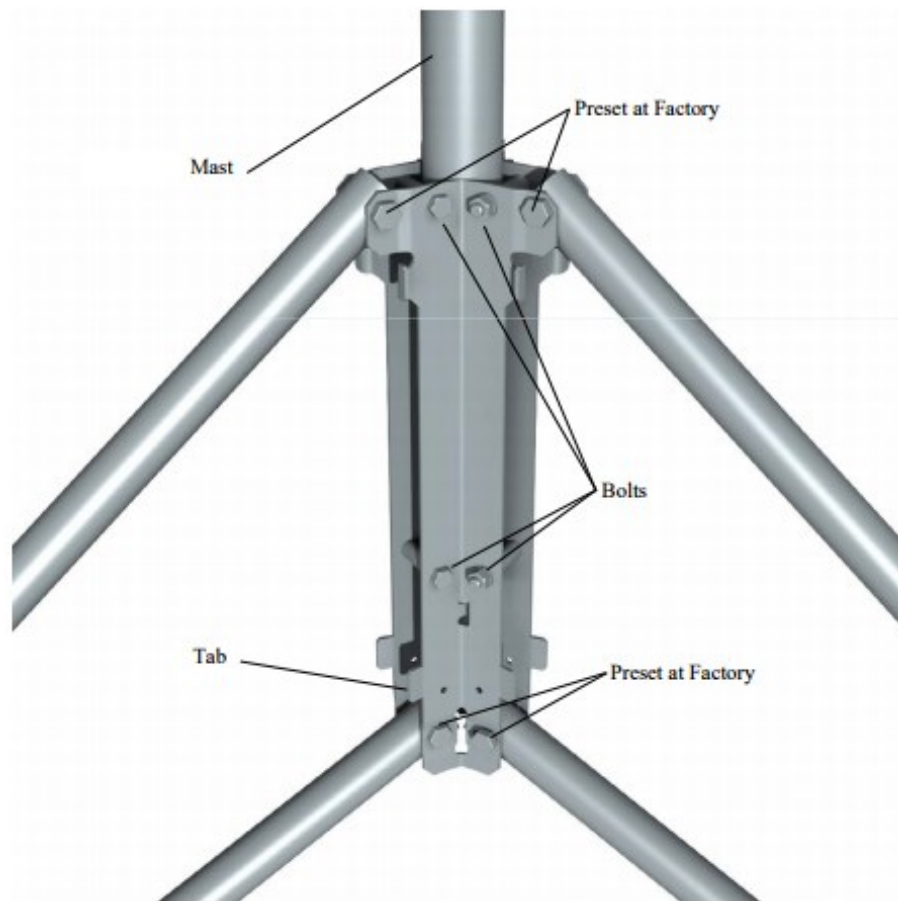

*FIGURE B-2. Staking the tripod feet*

Stakes may not be adequate depending on soil structure, maximum wind speeds experienced at the site, mast height, or wind load from the instrumentation. For questionable situations, additional stakes or even concrete footings for the tripod feet and guy anchors should be considered.

## B.3 Tripod mast

1. Loosen the six bolts on the tripod base. The following figure shows the location of four of these bolts. The remaining bolts are in the same position on the third tripod leg.



*FIGURE B-3. Mast attachment to tripod base*

2. Slide the mast into the tripod base, making sure that it extends below the lower bolts and rests on the tabs. Tighten the six bolts to secure the mast.
3. Plumb the tripod by adjusting the northeast and south facing legs. With a level on the east side of the mast, adjust the northeast leg for plumb. With the level on the south side of the mast, adjust the south leg for plumb. Tighten the tension bolts after the adjustments have been made.

## B.4 Tripod grounding

Place the clamp over the installed ground rod. Strip 1/2 in. of insulation from both ends of the black 4 AWG ground wire. Insert one end of the ground wire into the clamp and ground rod, and tighten the bolt on the clamp. Attach the other end of the ground wire to the lug on the tripod base as shown in the following figure.

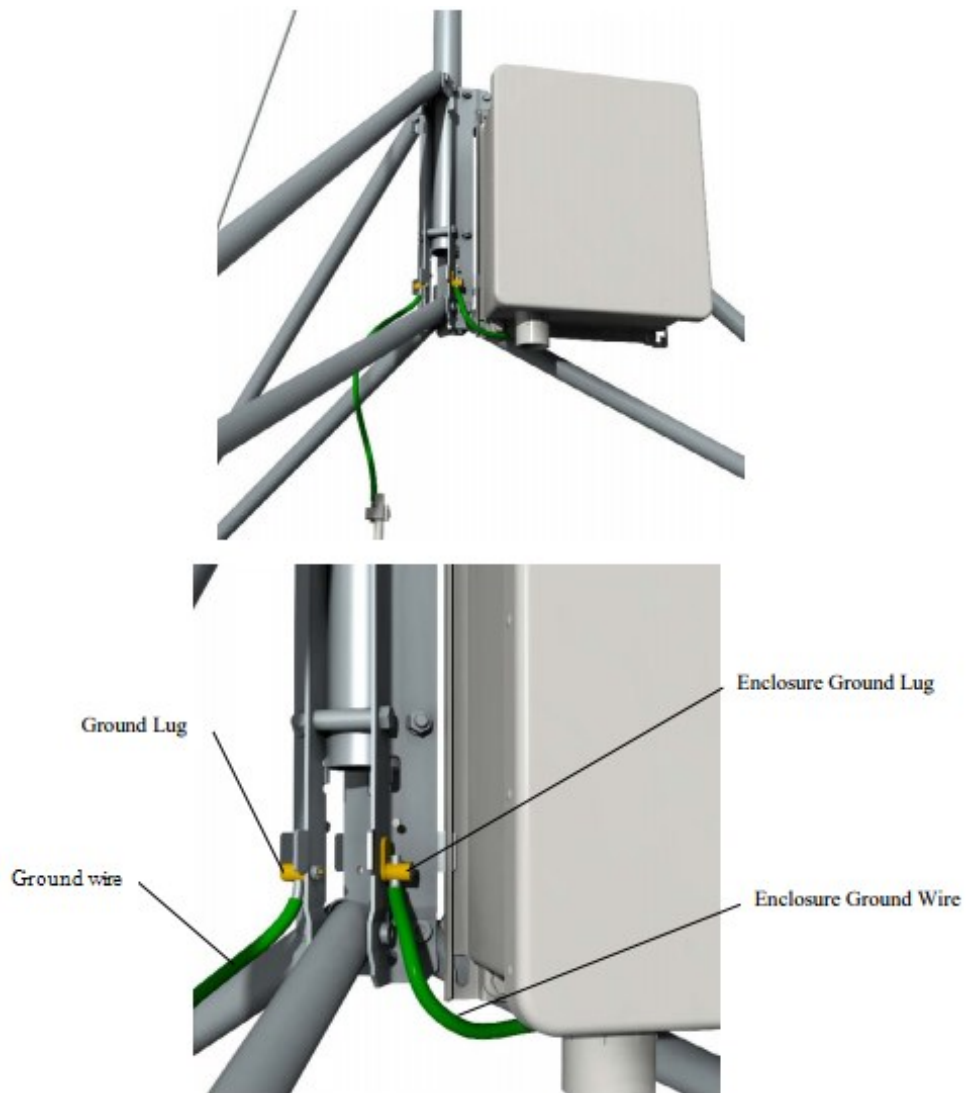

FIGURE B-4. Ground rod and clamp

**CAUTION:**

The tripod includes a lightning rod. DO NOT install the lightning rod, as it will adversely affect CS110 measurements.

# Appendix C. Installing a CM110 tripod

---

Contact local utility providers to locate any buried utilities prior to installation. Assemble the tripod so that the top is 2.54 m (100 inches) from the ground.

First, prepare the area where the tripod will be installed. The tripod requires an area approximately 2.1 m (7 ft) in diameter. See [Site selection](#) (p. 7). Next, using a sledge hammer or fence post driver, drive the grounding rod into the ground where the center of the tripod is to be located.

## C.1 Tripod base

1. Stand the tripod base on end and rotate the feet perpendicular to the legs.
2. Each leg has a slide collar and T-knob with a spring-loaded pin that locks into holes located on the underside of the leg, as shown in the following image. Extend each leg until the pin clips into the fourth hole from the foot. Tighten the T-knob. Extending the legs as described puts the feet on a circle with a radius of approximately 102 cm (40 inches).

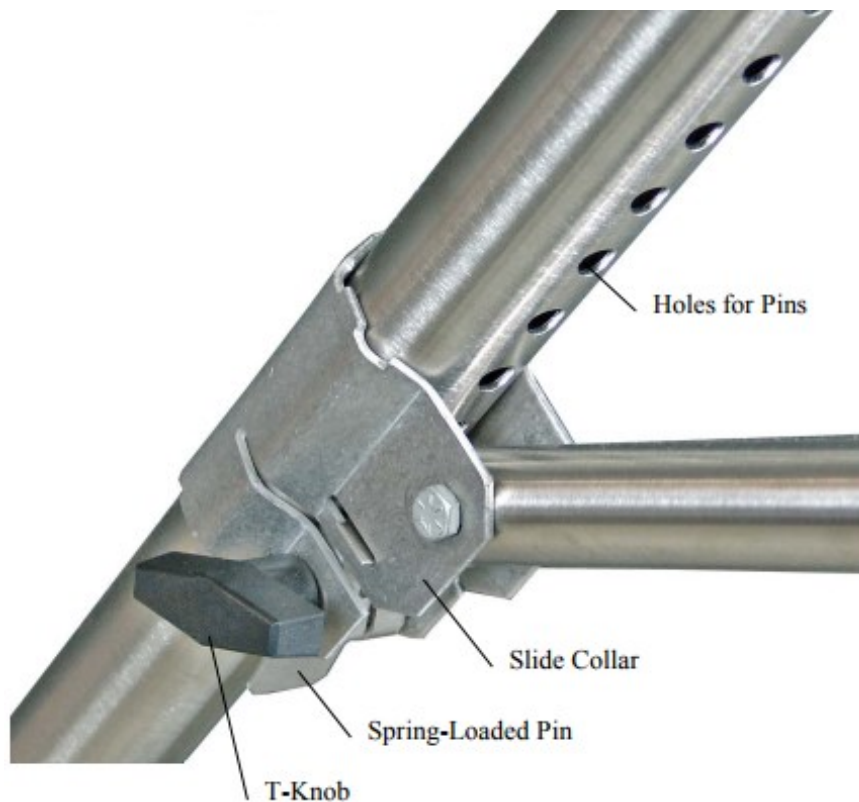

FIGURE C-1. Tripod leg, slide collar components

3. Center the tripod base over the installed grounding rod.
4. If a solar panel is being used, orient the tripod with the leg pointing toward the equator that allows the mast to tilt down away from the equator, and install the solar panel on that leg.

The tripod is typically plumbed (adjusted to vertical) after the mast has been installed.

## C.2 Tripod mast

1. The top mast section has a 56-inch insert used to lengthen the mast. Remove the bolt that secures the insert to the inside of the mast, and slide the insert out from the mast. Align the sixth hole of the insert with the oblong, second hole of the main mast. The longer end of the inner mast should be extending from the main mast. Replace the bolt. The sections of the mast should now be 211 cm (83 inches).
2. The tripod base has two sets of right-angled holes for attaching the mast; for the CS110, use the lower hole (see the following figure). The mast is attached to the base with a pin, and secured in the upright position with a locking bracket. Both the pin and the locking bracket are secured with a lanyard.

3. To attach the lower mast section, hold the mast upright and align the hole in the bottom of the mast with the holes in the tripod base. Insert the pin through the holes, and rotate the wire retainer over the end of the pin as shown in the following figure.
4. Secure the mast in the upright position by installing the locking bracket:
  - a. Insert the top of the bracket into the notches in the tripod base, and using both thumbs, press the bracket into the body of the base until the lower tabs lock into position.
  - b. Install the pin.
5. Plumb the tripod by adjusting the northeast and south facing legs. With a level on the east side of the mast, adjust the northeast leg for plumb. With the level on the south side of the mast, adjust the south leg for plumb.

## C.3 Staking tripod feet

Six stakes are provided for securing the tripod feet to the ground. Drive two stakes through holes in each foot at an angle as shown in the following image.



*FIGURE C-2. Staking the tripod feet*

Stakes may not be adequate depending on soil structure, maximum wind speeds experienced at the site, mast height, or wind load from the instrumentation. For questionable situations, additional stakes or even concrete footings for the tripod feet and guy anchors should be considered.



## C.4 Tripod grounding

Place the clamp over the installed ground rod. Strip 1/2 in. of insulation from both ends of the black 4 AWG ground wire. Insert one end of the ground wire into the clamp and ground rod, and tighten the bolt on the clamp. Attach the other end of the ground wire to the lug on the tripod base as shown in the following figure.

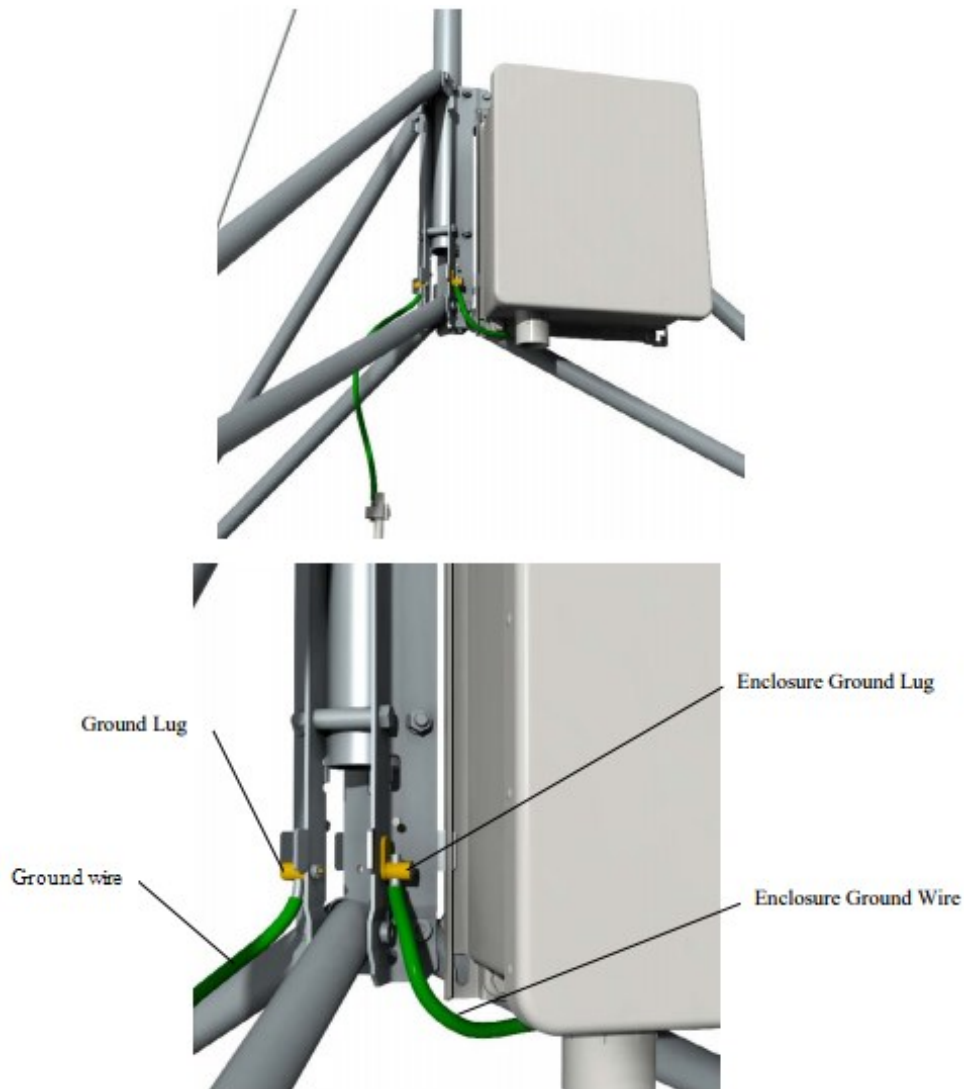

FIGURE C-3. Ground rod and clamp

**CAUTION:**

The tripod includes a lightning rod. DO NOT install the lightning rod, as it will adversely affect CS110 measurements.

# Appendix D. Mounting the enclosure on a tripod

---

Mount the enclosure on the left side of the leg pointed toward the equator.

Slide the keyhole notch in the upper corner of the enclosure leg-mount (-LM) bracket over the extended hook on the tripod base as shown in the following figure. Engage the notch in the lower corner of the bracket with the enclosure tab.

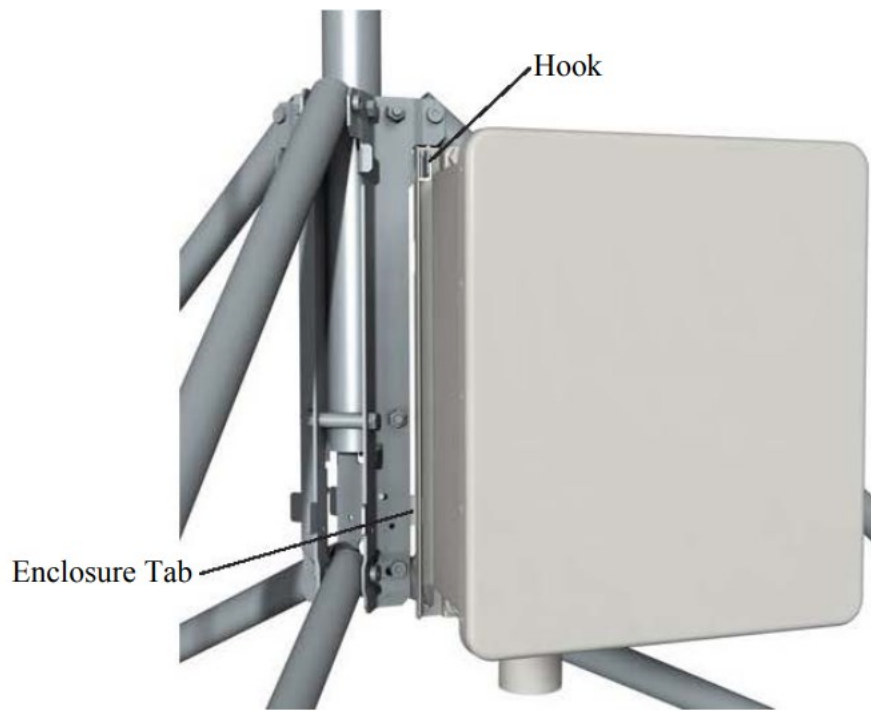

Use the U-bolt to secure the right enclosure bracket to the tripod leg. Tighten the nuts on the U-bolt until the lock washers are compressed.

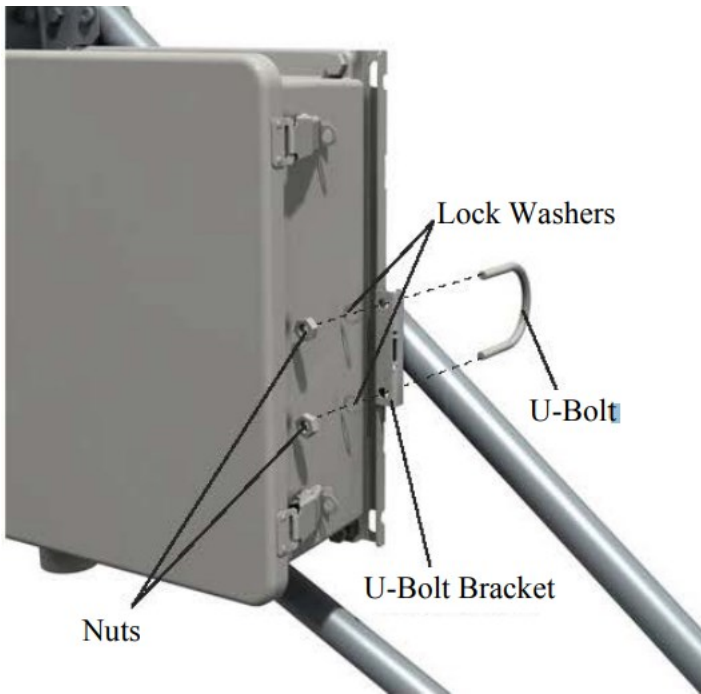

Route the 14 AWG wire from the ground lug on the bottom side of the enclosure to the ground lug on the base of the tripod. Strip 1/2 in. of insulation from each end of the wire. Insert wire ends into the ground lugs and tighten.

# Appendix E. Installing a CM500-series pole

---

Contact local utility providers to locate any buried utilities prior to installation.

## E.1 Installation in concrete foundation (without a pedestal)

1. Dig a hole 2.5 ft (76.2 cm) deep with a diameter of 2 ft (61 cm). The hole will require 6 inches (15.2 cm) of gravel backfill.
2. Place the pole in the center of the hole so it has a height of exactly 100 inches (2.54 m) above the surface. This height must be maintained as the mast is installed and the concrete is poured.
3. Fill the hole with concrete.
4. Plumb the pole (adjust to vertical) with a level.

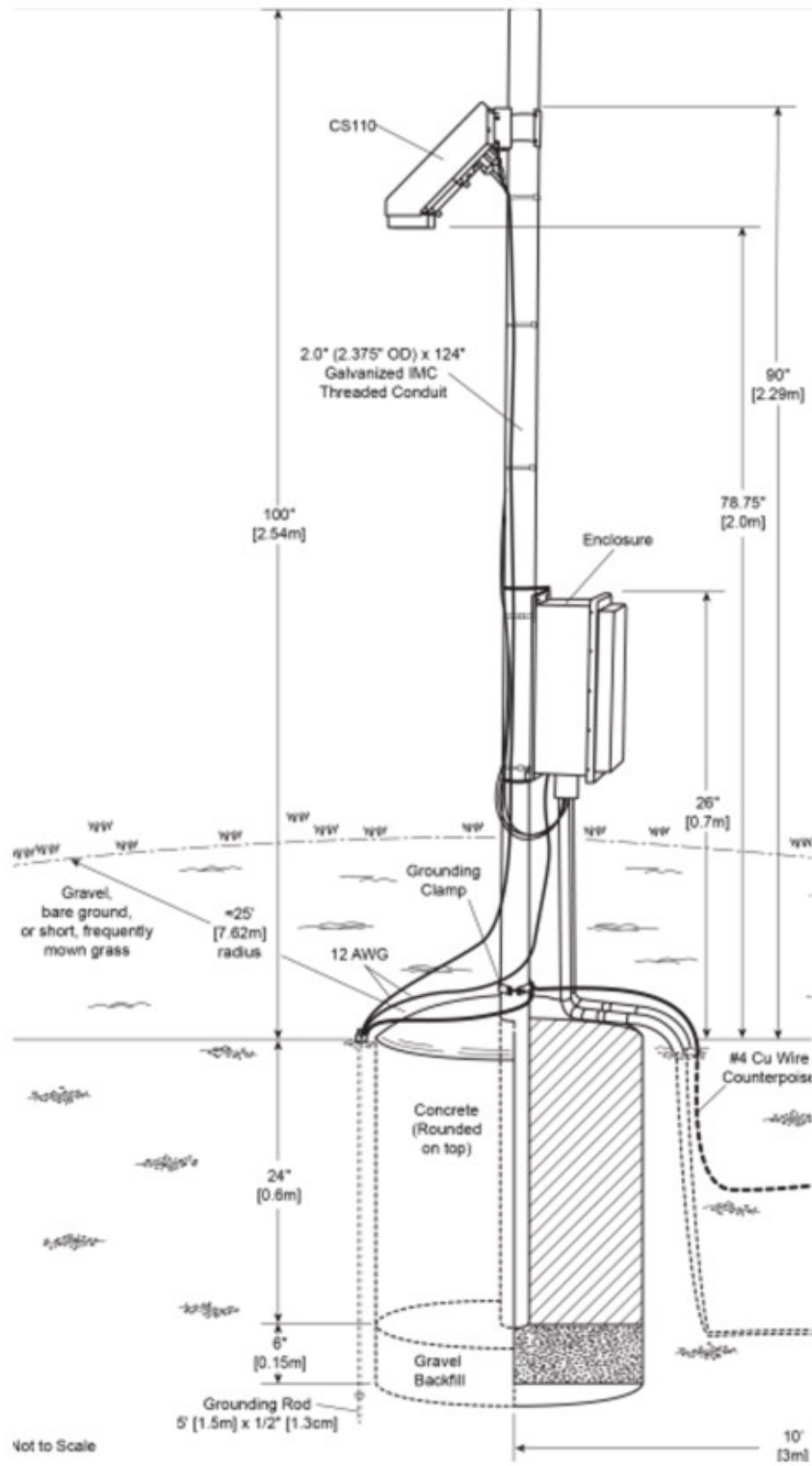

FIGURE E-1. Pole in concrete

## E.2 Installation with a pedestal

J-bolts are installed in a concrete foundation using the template provided with the pedestal J-bolt kit.

1. Construct a square form with inside dimensions of 35.6 cm (14 in) from 5 x 10 cm (2 x 4-in) lumber.
2. Cut two additional 45.7 cm (18 in) pieces from the lumber for later use as levelers.
3. Dig a hole 35.6 x 35.6 x 61 cm (14 x 14 x 24 in) deep (depth should exceed typical frost level). Center and level the form over the hole.



4. Install the J-bolts to the template using two nuts below the template and one above.
5. Fill the hole and form with concrete and place the two 46 cm (18-in) leveler pieces on top of the form. Insert the J-bolts into the concrete, with the bottom of the template resting on top of the spacers (template should be 10 cm (4 in) above the concrete).

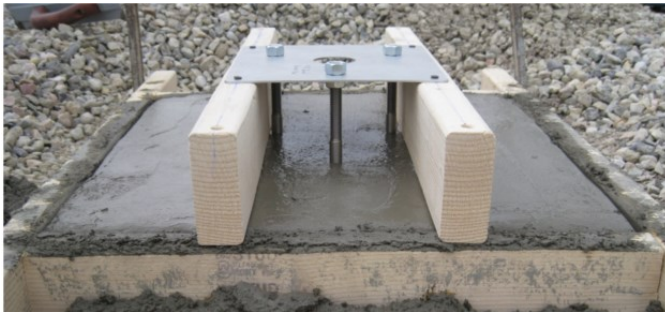

6. After the concrete has cured, remove the template, levelers, and square form.

7. Install one nut, one lock washer, and one flat washer on each J-bolt. The nuts should be about 3.8 cm (1.5 in) above the top of the concrete.



8. Place the pedestal over the J-bolts and install a flat washer, a lock washer, and a nut on each bolt. Do not tighten the nuts yet.



9. Insert the pole into the pedestal, and tighten the six bolts evenly.



10. Adjust the lower nuts on each J-bolt to plumb the pole. Lock the lower nuts together using two wrenches. Tighten the upper nuts to secure the pedestal to the J-bolts.



## E.3 Installation with concrete stud anchors and a pedestal

If using a preformed concrete pad, you may still use the pedestal J-bolt kit by installing stud anchors into the concrete.

1. Set the pedestal on the concrete and mark with a pencil where the holes will need to be drilled.
2. Drill the three holes 3 1/4 inches deep using a hammer drill with a 1/2-inch diameter carbide-tipped drill bit.
3. Clean out each hole of all debris and dust using a wire brush, compressed air, or vacuum.
4. Thread a nut onto the threaded end of each concrete stud anchor so the top of the nut is flush with the top of the concrete stud anchor.
5. Insert the concrete stud anchors, clipped end first, into the predrilled holes.
6. Strike the nutted end of the concrete stud anchors until a minimum of six threads are below the surface of the concrete.
7. Finish the installation as if the stud anchors were J-bolts as described previously.



## E.4 Pole grounding

Drive the ground rod into the ground next to the cement.

For installations without the pedestal, mount the ground clamp to the mast below the enclosure. Attach the 4 AWG wire to the ground clamp and the ground rod.

For installations with the pedestal, ground the mast by attaching the 4 AWG wire to the ground lug on the pedestal and the ground rod. Mount the ground clamp to the mast below the enclosure. Attach the 4 AWG wire to the ground clamp and the ground rod.

# Appendix F. Mounting the enclosure on a CM500-series pole

---

A system ordered with this option will be shipped with brackets, metal bands, and mounting hardware needed to secure the enclosure. The metal bands are routed through the brackets and then around a vertical pole. They are anchored in place using screw clamps.

Mount the enclosure to the mast opposite the CS110, with the top of the enclosure 26 inches (66 cm) above the ground.

1. Position a bracket at the top of the enclosure as shown in the following figure. Secure it with a bolt, washer, and locknut at each end. Attach the lower bracket in the same manner, rotating the bracket so it extends below the enclosure.

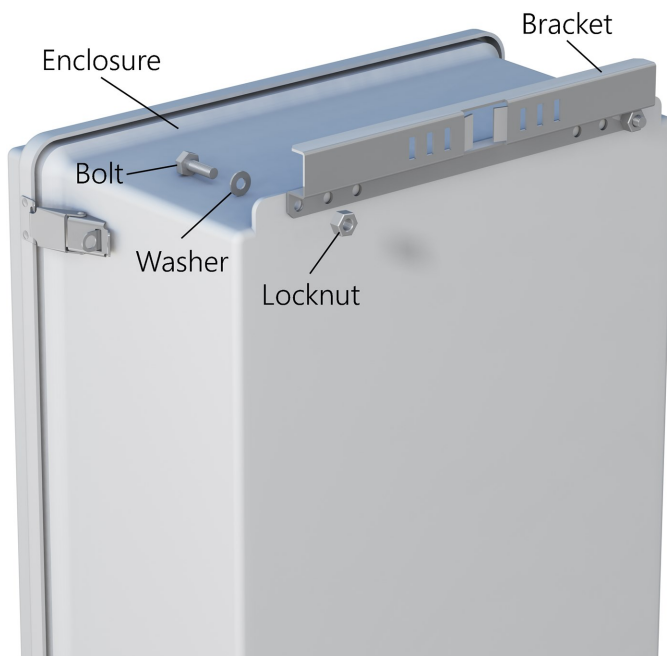

2. Feed a metal band through the openings in each bracket as shown in the following figure. Use the closest set of holes for smaller poles and the farthest set of holes for larger poles.

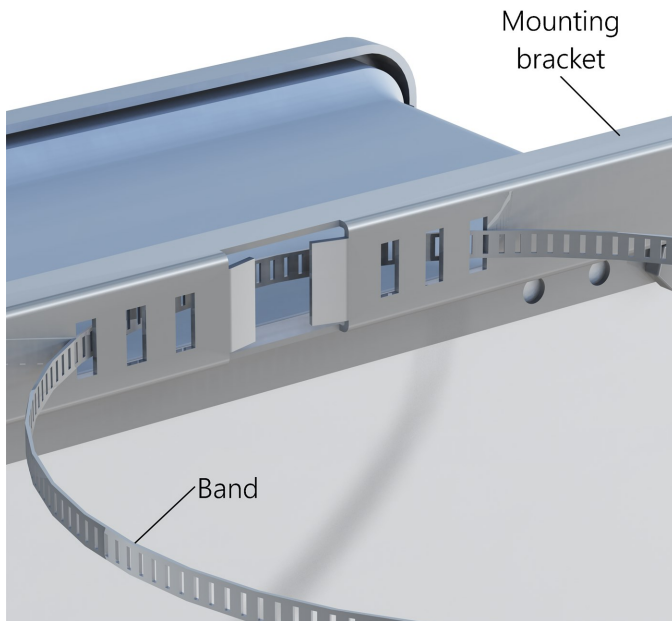

3. Position the enclosure on the side opposite the CS110.
4. Place the enclosure with the top 26 inches above the ground.
5. Insert the tab on the end of the screw threads into the hole at one end of the upper strap.

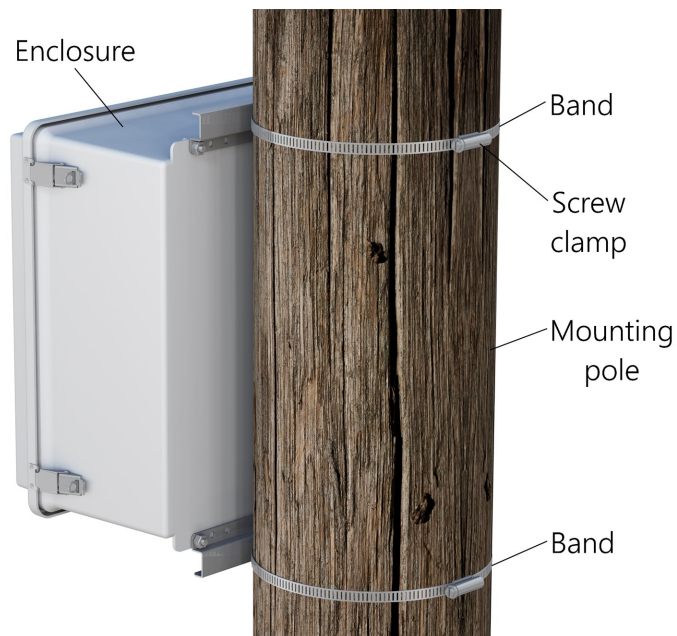

6. Pull the strap tight around the pole to determine which hole to insert the screw clamp at the other end of the strap. Insert the clamp into this hole.
7. Use metal shears to remove any excess strap, leaving a small amount for adjustments.
8. Insert the screw threads into the screw clamp and tighten, using a flathead screwdriver or nut driver.
9. Repeat steps 5 through 8 for the lower strap.

Route the 12 AWG grounding wire from the brass grounding clamp on the ground rod to the enclosure grounding lug. Strip one inch of insulation from each end of the wire. Insert the end of the wire into the grounding lugs and tighten.

# Appendix G. Installing an RA100 remote alarm

---

The RA100 may be mounted either to a parapet wall using the RA1 Flat Mount option, or to a fixed pole or tripod using the RA2 Pole Mount option.

## G.1 Mounting on a flat wall (RA1 option)

This option provides two stainless-steel brackets for mounting the RA100 on a flat surface. You will need the following equipment:

- Drill with 6.5 mm (0.25 in) drill bits
- Hammer
- M6 (0.25 in) expansion bolts
- RA100
- Flat Mount mounting kit

Mount according to the following directions:

1. Insert the mast extension into the RA100 and bolt into place.
2. Position the RA100 to your liking. Place one bracket over the mast extension, just below the joint, and mark the wall where it will need to be drilled. Position the second bracket at least two feet below the top bracket, and do the same.
3. Set the RA100 aside, and drill into the wall using 6.5 mm (0.25 in) drill bits.
4. Hammer M6 (0.25 in) expansion anchors into these holes.
5. Mount the RA100 and tighten the bolts.

## G.2 Mounting on a pole or tripod (RA2 option)

This option is used to mount to a pole or tripod with a 6.1 cm (2.4 in) outer diameter (OD).

# Appendix H. Installing the SG000 Strike Guard

---

**CAUTION:**

The SG000 has a glass diffuser dome. Use extra care in handling the sensor to avoid breaking the dome.

**CAUTION:**

The plastic fiber optic cable must be handled with care to prevent kinking or bending the fiber core. Kinks and sharp bends in the fiber will attenuate light transmission through the fiber and may prevent the system from working. Once the cable is kinked or sharply bent, it will likely not recover. Use light pulling forces, and keep bends as gradual as possible, with bend radii never any less than 8 inches (20.3 cm). Do not step on the fiber and do not lay the fiber directly on a hot surface.

**CAUTION:**

The fiber has been pre-cut (properly cleaved) and tested at the factory for maximum light transmission. If, during handling or pulling, you damage, scratch, or otherwise foul the end of the cable, call Campbell Scientific, Inc for assistance.

The SG000 Strike Guard is self-powered with long-life lithium batteries that are capable of operating the SG000 for over four years in a typical installation.

The SG000 powers off when inverted, which is why it is packaged and shipped upside-down.

Mount and connect the SG000 as follows:

1. Use the attached U-bolt to mount the SG000 Strike Guard to the mast with the top of the metal mounting bracket level with the top of the mast.
2. Connect the fiber optic cable to the SG000. Run the cable down the mast and up into the enclosure, keeping the bend radii in the fiber always above 8 inches (20 cm). Connect the fiber optic cable to the FC100 Strike Guard Fiber-Optic Converter **RX** connector.
3. Connect a serial cable from the FC100 **RS-232** port to the CS110 **RS-232** port.

# Appendix I. CS110 as a slow antenna

---

The CS110 can sample the external electric field at a maximum rate of 5 Hz (200 ms) using the [CS110\(\)](#) instruction. Faster sampling of the rapid electric field changes associated with lightning discharges is desirable in some applications, and can be accomplished with the CS110 electric field meter configured as a slow antenna, also known as a field change meter.

## I.1 Slow antenna response in frequency domain

The CS110 as a slow antenna with the 250  $\mu$ s integration responds to events as shown in ([FIGURE I-1](#) (p. 60)). The lower frequency limit is due to the measurement circuitry and the upper frequency limit is a function of the integration time. Both are explained in the following sections.

The [CS110Shutter\(\)](#) instruction can be used to fully open the shutter, indefinitely exposing the sense electrode to external fields. Execution of the [CS110Shutter\(\)](#) instruction with the open command changes the CS110 panel board charge amplifier circuitry to a slow antenna by switching in a 200 M $\Omega$  resistor in parallel with the 330 pF feedback capacitor, resulting in a  $(330 \text{ pF})(200 \text{ M}\Omega) = 66 \text{ ms}$  decay time constant. In this slow antenna configuration, the charge amplifier has a high-pass filter frequency response with the lower cutoff frequency defined by the decay time constant such that  $f_{3 \text{ dB}} = (2\pi RC)^{-1} = 2.4 \text{ Hz}$ . This means that events with frequencies higher than 2.4 Hz (shorter than 417 ms) are passed through, while lower frequency events are cut off. The  $-3\text{dB}$  point for voltage is:

$$-3\text{dB} = \sqrt{10^{-3/10}} = 0.708 \text{ of true}$$

The CS110 can measure the slow antenna output at rates up to 50 Hz (100 Hz may be possible but it has not been tested), using the fast integration (250  $\mu$ s integration) for the [VoltDiff\(\)](#) instruction. Voltage measurements using the 250  $\mu$ s integration duration for the analog integrator, result in an upper 3 dB bandwidth of 1.8 kHz (0.555 ms). The following shows the combined effect of both filters.

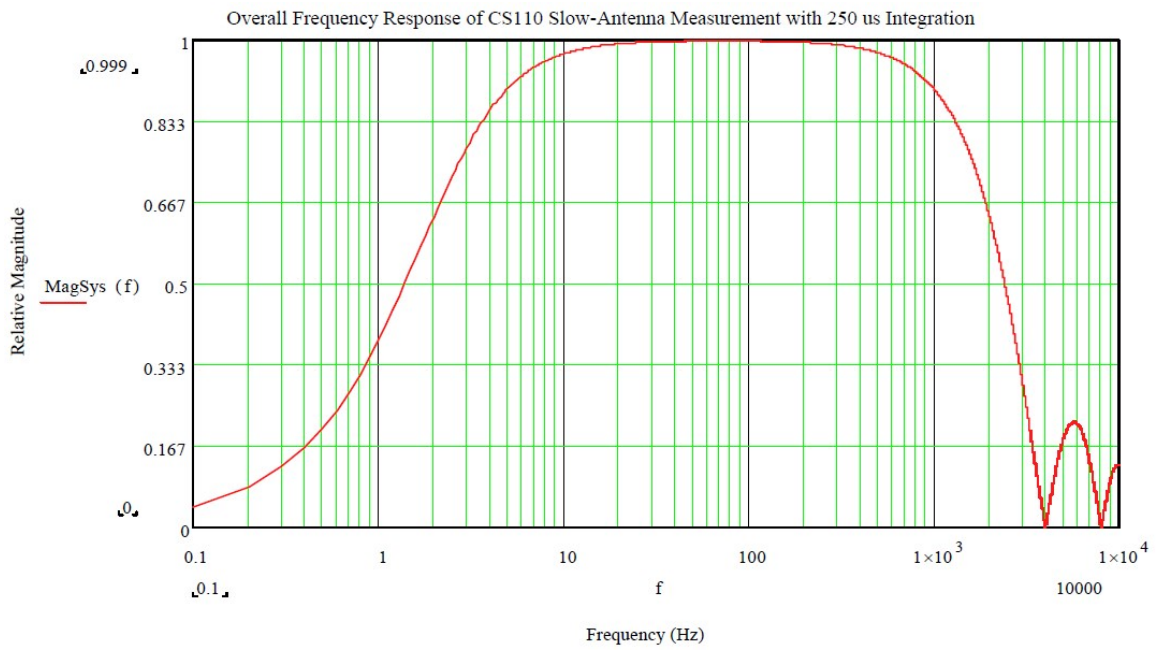

FIGURE I-1. CS110 slow antenna frequency response

## I.2 Slow antenna response in time domain

The following graphs shows one lightning strike measured at 50 Hz by both the CS110 slow antenna and by one of Kennedy Space Center (KSC) field mills. In FIGURE I-3 (p. 61), the KSC electric field meter readings have been converted to efield change per measurement.



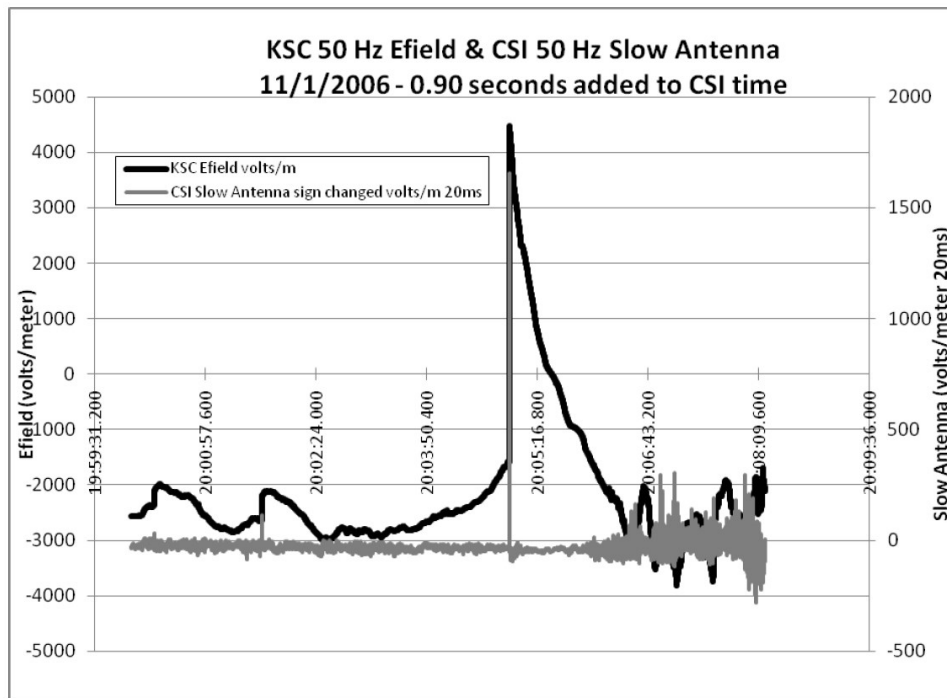

FIGURE I-2. KSC electric field and CS110 slow antenna data

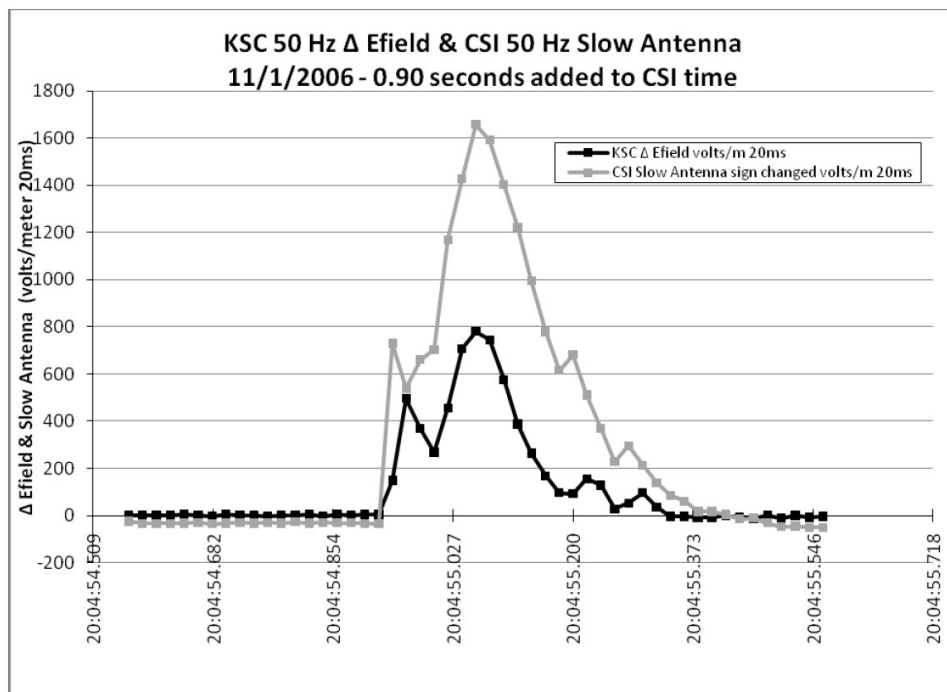

FIGURE I-3. KSC electric field change and CS110 slow antenna data

The KSC electric field mill and the CS110 were not precisely synced accounting for some of the differences in the data shown in [FIGURE I-3](#) (p. 61). Since that time, CS110 design improvements

now allows the CS110 to sync to within  $\pm 10 \mu\text{s}$  of the GPS signal PPS pulse. The resolution of accuracy for the clock set is 10 microseconds if the internal CR1000 data logger has a hardware revision number greater than 007 (RevBoard field in the data logger's Status table).

## I.3 Slow antenna programming

In [CRBasic Example 1](#) (p. 62), the `PipeLineMode` instruction enables parallel task processing necessary to complete a scan in 20 ms. The CS110 instruction following the `BeginProg` statement provides a measure of the absolute electric field along with a leakage current compensation value, and is only executed once. The `CS110Shutter()` instruction can fully open or fully close the shutter, based on the whether the second parameter is 1 or 0, respectively. Two `VoltDiff()` instructions used on two different input voltage ranges provide more dynamic range in the charge amplifier output measurement.

### CRBasic Example 1: Slow antenna example program

```
PipeLineMode

Const Mult = 85
Public Delta_E
Public Delta_E_mV2500
Public stat(2)
Public E_field
Public Leakage

DataTable(SlowAnt,1,-1)
  Sample(1,Delta_E,IEEE4)
EndTable

BeginProg
  CS110 (E_field,Leakage,stat(1),250,Mult,0) 'Measure E_field and leakage
  CS110Shutter(stat(2),1) 'Fully open shutter.
  Scan(20,msec,0,0)
  VoltDiff (Delta_E,1,mV250,8,False,0,250,Mult,0) 'no input reversal.
  VoltDiff (Delta_E_mV2500,1,mV2500,8,False,0,250,Mult,0) 'no input reversal.

  If Delta_E = NAN Then
    Delta_E = Delta_E_mV2500
  EndIf

  CallTable SlowAnt
NextScan
EndProg
```

The CS110 can be programmed to operate as a field meter and then switch to operate as a slow antenna. For example, efield measurements may be desired until they exceed an alarm threshold

of +1500 V/m after which slow antenna (field change) measurements may be desired. The CR1000 operating system does not allow the **Sequential** and **Pipeline** modes to be used in the same program. For the CS110 to be able to switch between measuring the electric field with the **CS110()** instruction and the electric field change in the slow antenna mode, the slow antenna instructions must be run in the Sequential Mode. One way to accomplish this is to program the CR1000 to monitor a 1 minute running average of efield and when it exceeds +1500 V/m switch to the slow antenna mode for a fixed amount of time then return to the field meter mode.

## I.4 Calibration

The factory calibration described in [Factory calibration of the CS110](#) (p. 19) applies to the maximum amplitude of the step response of the CS110 when it is operating as a slow antenna. Switching in the 200 M $\Omega$  resistor in the feedback path simply slows the decay of the signal induced on the sense electrode resulting in a 66 millisecond decay time constant. The CS110 operating as a slow antenna returns the change in the electric field with units of volts per meter per scan. A 50 Hz scan interval would yield: ( X V/m)/(20 ms).

# Appendix J. Site calibration using transfer standard on CM310s

---

Using the  $M_{\text{parallel\_plate}}$  from the factory calibration, the CS110 measures the electric field ( $e_{\text{field}}$ ) induced on the sense electrode. When installed at the surface of the ground facing up, the CS110 measures the Earth true electric field at that point.

To measure the Earth true  $e_{\text{field}}$  when the CS110 is mounted above the ground pointing down, a site calibration must be done to determine a multiplier, known as the  $C_{\text{site}}$  or enhancement factor. The  $C_{\text{site}}$  multiplier is applied to the uncorrected  $e_{\text{field}}$  measured by the downward facing CS110 to obtain the Earth true electric field. The  $C_{\text{site}}$  multiplier corrects for the height of the CS110 face above the ground and its distance below the top of the grounded metal mounting structure.

Campbell Scientific calculated a  $C_{\text{site}}$  for the configurations described in this document. Change the  $e_{\text{field}}$  and  $C_{\text{site}}$  when the CS110 uses a different mounting configuration, when the mounted CS110 is on a peaked roof or near the edge of a flat roof (magnifies the  $e_{\text{field}}$ ), and when the mounted CS110 is near a taller object that obstructs more than the 18 degree above the horizon (reduces the  $e_{\text{field}}$ ).

In most situations, if using a corrected  $e_{\text{fields}}$ , the criteria for the lightning hazard alarm level can be either the US Navy level of 2000 V/m or NASA 1500 V/m launch. Uncorrected  $e_{\text{field}}$  require the caution and alarm thresholds to be adjusted based on your observations of lightning danger. Exceptions to the Navy or NASA level are hill and mountain tops installations, and cold storms. Hill and mountain tops typically experience higher electric fields than flat locations even during fair weather conditions. Free ions are attracted to a charge of the opposite polarity. Consequently they congregate at the high points before bleeding off, sometimes in a corona discharge called St. Elmo's fire. As a result of the higher concentration of charge, even if the CS110 is mounted in a standard configuration on high ground, you will likely have to adjust your alarm threshold based on some history of observed lightning and measured electric fields. Second, the lowest charged layer in an electrified cloud occurs at the bottom of the freezing level. Precipitation will lower some of that charge to the ground. For a given charge in a cloud, the closer the freezing level is to the ground, the higher the  $e_{\text{field}}$  because the distance between the charged layer and the ground is reduced; the number of meters in the denominator of V/m is reduced yielding higher

V/m with the same charge. Consequently, cold storms often induce higher electric fields at the ground but they may not produce lightning.

## J.1 Site calibration

The site calibration requires two CS110 electric field meters. One CS110 is the the reference calibrator and the other CS110 is the *device under calibration* (DUC). The reference *calibrator* can be a CS110 installed on the ground surface facing up or the *Transfer Standard* installation shown in [FIGURE J-1](#) (p. 65). The downward facing *Transfer Standard* calibrator is easier to use because it is not affected by rain and dirt whereas the up facing CS110 calibrator is.



FIGURE J-1. Transfer Standard CS110 on CM310/CM350 at 1.2 meters

A site calibration is a regression of data obtained during a high  $e_{\text{field}}$  event from the reference calibrator (Y axis) and the DUC (X axis). The following example shows the site calibration done for the *Transfer Standard* using a CS110 installed at the surface of the ground facing up. The regression yields a  $C_{\text{site}}$  of 0.16.

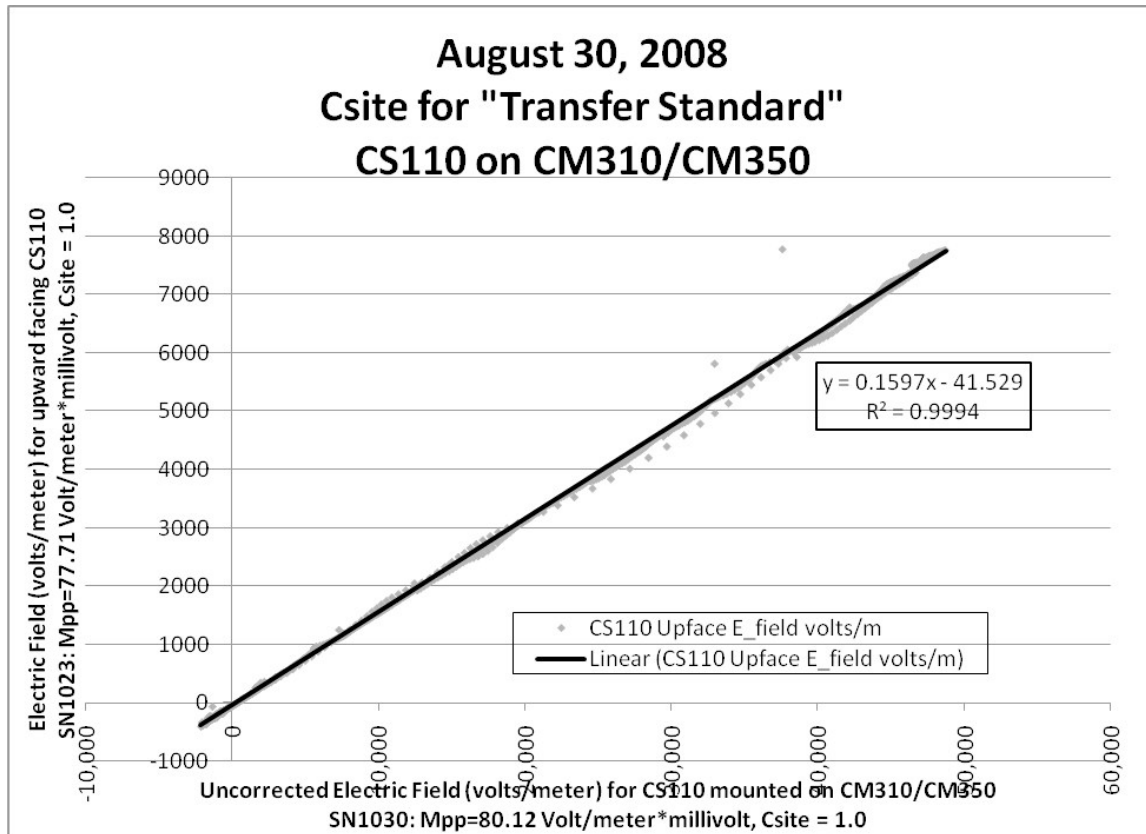

FIGURE J-2. Regression to determine  $C_{\text{site}}$  multiplier

1. Install the DUC in its permanent location.
2. Install the calibrator as close to the DUC as possible, where it is free from obstructions blocking its view of the sky more than 18 degrees above the horizon. The following sections include the setup instructions for the *Transfer Standard* calibrator. A downloadable calibration program is available at available at: [www.campbellsci.com/downloads/cs110-programs](http://www.campbellsci.com/downloads/cs110-programs)
3. In the DUC program, use its unique  $M_{\text{parallel\_plate}}$  calibration factor and a  $C_{\text{site}}$  of 1.
4. In the calibrator program, use its unique  $M_{\text{parallel\_plate}}$  calibration factor and a  $C_{\text{site}}$  of 0.16 for the *Transfer Standard* configuration or a  $C_{\text{site}}$  of 1.0 for an up-facing calibrator.
5. Sync the clocks in both CS110s.



- Retrieve the data recorded by the CS110s during a high field event and import it into Excel or a similar software package. One second  $e_{\text{field}}$  data is better for regression than the one minute  $e_{\text{field}}$  values because one second data show spikes due to lightning which can be used to make sure the data is synced to within 1 second. However, one second data fills the memory within 19 hours; whereas the one minute data fills the memory in three days. In some cases, it may be necessary to use one minute data captured from a storm during a weekend.
- Process the data in a manner similar as [FIGURE J-1](#) (p. 65). In that example, the regression yields a  $C_{\text{site}}$  multiplier of 0.16. The  $C_{\text{site}}$  used by the DUC to measure the data is multiplied by the regression value. In this case, the DUC data was measured using a  $C_{\text{site}}$  of 1.0, which when multiplied by the regression value of 0.16 yields the new  $C_{\text{site}}$  value of 0.16.

## J.2 Transfer standard installation

The transfer standard configuration consists of the CS110 mounted flush with the top of the CM310 142 cm (56 in) mounting pole with the 58.4 cm (23-in) legs and power supply housed in a 30.5 cm by 35.6 cm (12-in by 14-in) enclosure. Each leg attaches to the pedestal base with two bolts. The pedestal base has a set of three holes for each leg. The angle of the legs, and resultant pedestal height, is determined by which hole the end bolt is placed through.

- Attach the legs to the pedestal base and tighten the bolts (do not overtighten). For the end bolts, use the hole that places the legs in the most horizontal position. This puts the face of the CS110 at a height of 119 cm (46.75 in) and the top of the mast at 147 cm (58 in).



- Place the pole into the base and tighten the six bolts evenly.

3. Mount the CS110 flush with the top of the CM310.



4. Mount the enclosure on the CM310 mast with the bottom bracket resting on the pedestal base.
5. Ground the pedestal and power supply:
  - a. Install the ground rod
  - b. Attach a 4 AWG wire to the pedestal ground lug.



- c. Attach a 4 AWG wire to the enclosure ground lug.



- d. Attach the 4 AWG wires to the ground rod.



6. Connect the CS110 power cable to the CS110 **POWER** connector.
7. Route the cable down the pole and into the enclosure conduit.
8. Connect the black and clear wire to  $\perp$  terminals on the PS150 or CH150 and red wire to the +12 terminal.
9. Use cable ties to secure the cable to the pole.
10. Connect the green ground wire from the ground lug at the bottom of the enclosure to a  $\perp$  terminal on the PS150 or CH150.

## J.3 Site calibration cautions

The greater the distance between the calibrator and the DUC, the greater the potential for error in the resulting  $C_{\text{site}}$  multiplier. [FIGURE J-3](#) (p. 70) show the potential for error at separation distances of 200 m, 15 m, 30 m and 10 m. An  $e_{\text{field}}$  ratio (DUC/Calibrator) of 0.9 or 1.1 means that the regression derived  $C_{\text{site}}$  multiplier and resulting  $e_{\text{fields}}$  will be off by 10%.

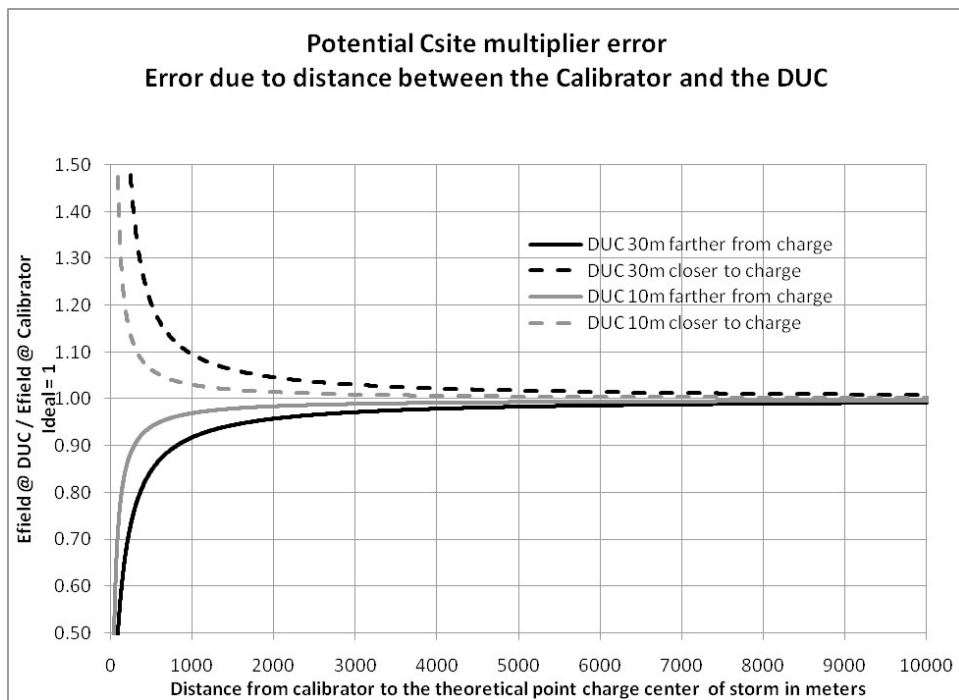
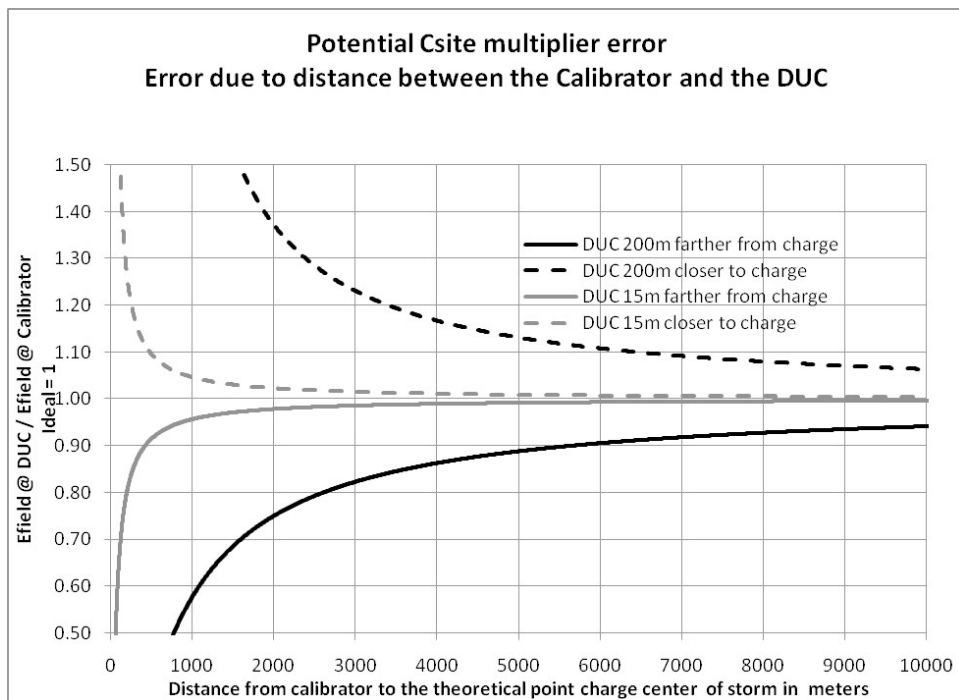

FIGURE J-3. Graphs showing potential  $C_{site}$  multiplier errors

FIGURE J-4 (p. 71) and FIGURE J-5 (p. 72) show the site calibration results for a DUC when the “Transfer Standard” calibrator was 200 meters away during three high field events on that day. The poor  $r^2$  values and the large difference in the  $C_{site}$  regression between the third storm and all three storms are indicative of the problems associated with large separation distances. Larger

storms with a more uniformly charged stratus layer may work better. Site calibrations where the calibrators have to be so distant may only be possible if four calibrators can be setup on the compass points around the DUC.

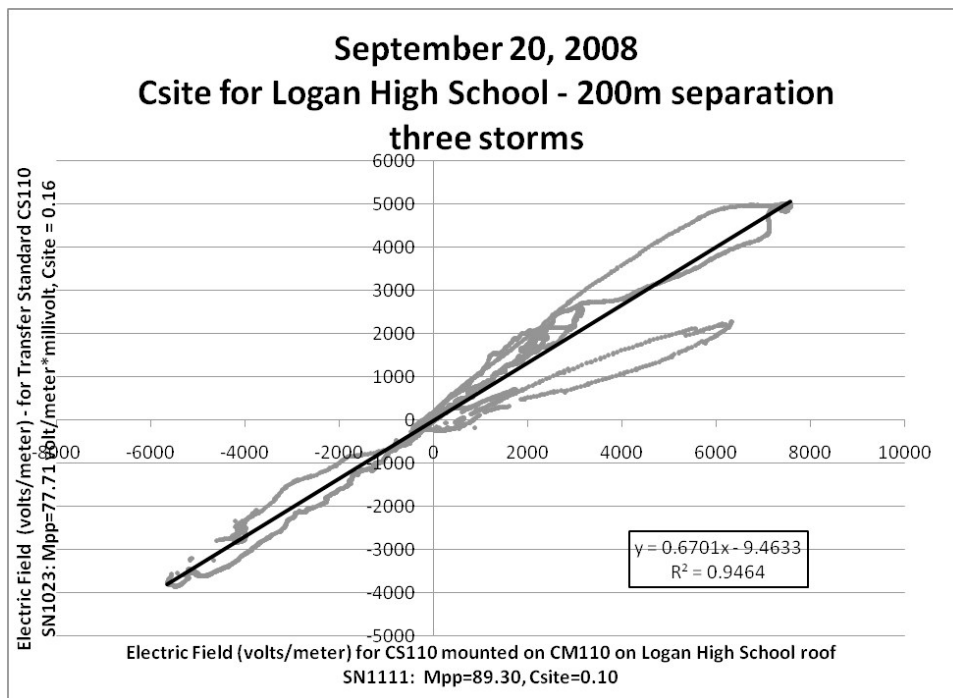

FIGURE J-4.  $C_{site}$  regression for three separate storms

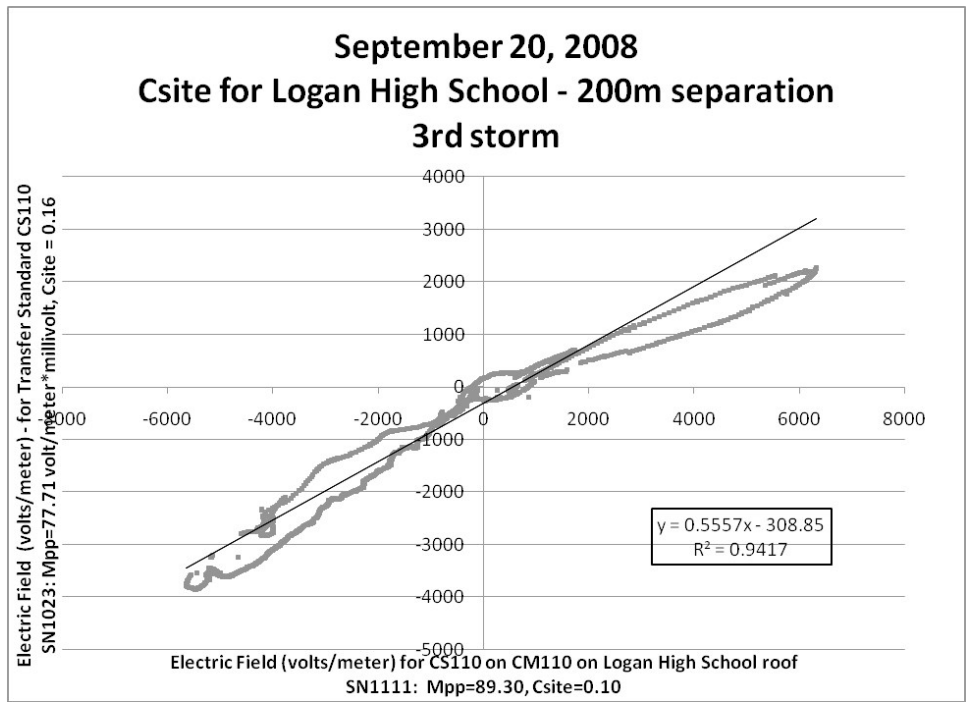

FIGURE J-5.  $C_{site}$  regression for the third storm

# Limited warranty

---

Products manufactured by Campbell Scientific are warranted by Campbell Scientific to be free from defects in materials and workmanship under normal use and service for twelve months from the date of shipment unless otherwise specified on the corresponding product webpage. See Product Details on the Ordering Information pages at [www.campbellsci.com](http://www.campbellsci.com). Other manufacturer's products, that are resold by Campbell Scientific, are warranted only to the limits extended by the original manufacturer.

Refer to [www.campbellsci.com/terms#warranty](http://www.campbellsci.com/terms#warranty) for more information.

**CAMPBELL SCIENTIFIC EXPRESSLY DISCLAIMS AND EXCLUDES ANY IMPLIED WARRANTIES OF MERCHANTABILITY OR FITNESS FOR A PARTICULAR PURPOSE.** Campbell Scientific hereby disclaims, to the fullest extent allowed by applicable law, any and all warranties and conditions with respect to the Products, whether express, implied or statutory, other than those expressly provided herein.

# Assistance

---

Products may not be returned without prior authorization.

Refer to [www.campbellsci.com/repair](http://www.campbellsci.com/repair) for up-to-date repair information.

The following contact information is for US and international customers residing in countries served by Campbell Scientific, Inc. directly. Campbell Scientific regional offices handle repairs for customers within their territories. Please visit [www.campbellsci.com/contact](http://www.campbellsci.com/contact) to determine which Campbell Scientific office serves your country.

To obtain a Returned Materials Authorization (RMA) number, contact CAMPBELL SCIENTIFIC, INC., phone (435) 227-9000. Please write the issued RMA number clearly on the outside of the shipping container. Campbell Scientific's shipping address is:

**CAMPBELL SCIENTIFIC, INC.**

RMA# \_\_\_\_\_

815 West 1800 North

Logan, Utah 84321-1784

For all returns, the customer must fill out a "Statement of Product Cleanliness and Decontamination" form and comply with the requirements specified in it. The form is available from our website at [www.campbellsci.com/repair](http://www.campbellsci.com/repair). A completed form must be either emailed to [repair@campbellsci.com](mailto:repair@campbellsci.com) or faxed to (435) 227-9106. Campbell Scientific is unable to process any returns until we receive this form. If the form is not received within three days of product receipt or is incomplete, the product will be returned to the customer at the customer's expense. Campbell Scientific reserves the right to refuse service on products that were exposed to contaminants that may cause health or safety concerns for our employees.

# Safety

---

**DANGER — MANY HAZARDS ARE ASSOCIATED WITH INSTALLING, USING, MAINTAINING, AND WORKING ON OR AROUND TRIPODS, TOWERS, AND ANY ATTACHMENTS TO TRIPODS AND TOWERS SUCH AS SENSORS, CROSSARMS, ENCLOSURES, ANTENNAS, ETC.** FAILURE TO PROPERLY AND COMPLETELY ASSEMBLE, INSTALL, OPERATE, USE, AND MAINTAIN TRIPODS, TOWERS, AND ATTACHMENTS, AND FAILURE TO HEED WARNINGS, INCREASES THE RISK OF DEATH, ACCIDENT, SERIOUS INJURY, PROPERTY DAMAGE, AND PRODUCT FAILURE. TAKE ALL REASONABLE PRECAUTIONS TO AVOID THESE HAZARDS. CHECK WITH YOUR ORGANIZATION'S SAFETY COORDINATOR (OR POLICY) FOR PROCEDURES AND REQUIRED PROTECTIVE EQUIPMENT PRIOR TO PERFORMING ANY WORK.

Use tripods, towers, and attachments to tripods and towers only for purposes for which they are designed. Do not exceed design limits. Be familiar and comply with all instructions provided in product manuals. Manuals are available at [www.campbellsci.com](http://www.campbellsci.com). You are responsible for conformance with governing codes and regulations, including safety regulations, and the integrity and location of structures or land to which towers, tripods, and any attachments are attached. Installation sites should be evaluated and approved by a qualified engineer. If questions or concerns arise regarding installation, use, or maintenance of tripods, towers, attachments, or electrical connections, consult with a licensed and qualified engineer or electrician.

## General

- Protect from over-voltage.
- Protect electrical equipment from water.
- Protect from electrostatic discharge (ESD).
- Protect from lightning.
- Prior to performing site or installation work, obtain required approvals and permits. Comply with all governing structure-height regulations, such as those of the FAA in the USA.
- Use only qualified personnel for installation, use, and maintenance of tripods and towers, and any attachments to tripods and towers. The use of licensed and qualified contractors is highly recommended.
- Read all applicable instructions carefully and understand procedures thoroughly before beginning work.
- Wear a **hardhat** and **eye protection**, and take **other appropriate safety precautions** while working on or around tripods and towers.
- **Do not climb** tripods or towers at any time, and prohibit climbing by other persons. Take reasonable precautions to secure tripod and tower sites from trespassers.
- Use only manufacturer recommended parts, materials, and tools.

## Utility and Electrical

- **You can be killed** or sustain serious bodily injury if the tripod, tower, or attachments you are installing, constructing, using, or maintaining, or a tool, stake, or anchor, come in **contact with overhead or underground utility lines**.
- Maintain a distance of at least one-and-one-half times structure height, 20 feet, or the distance required by applicable law, **whichever is greater**, between overhead utility lines and the structure (tripod, tower, attachments, or tools).
- Prior to performing site or installation work, inform all utility companies and have all underground utilities marked.
- Comply with all electrical codes. Electrical equipment and related grounding devices should be installed by a licensed and qualified electrician.

## Elevated Work and Weather

- Exercise extreme caution when performing elevated work.
- Use appropriate equipment and safety practices.
- During installation and maintenance, keep tower and tripod sites clear of un-trained or non-essential personnel. Take precautions to prevent elevated tools and objects from dropping.
- Do not perform any work in inclement weather, including wind, rain, snow, lightning, etc.

## Maintenance

- Periodically (at least yearly) check for wear and damage, including corrosion, stress cracks, frayed cables, loose cable clamps, cable tightness, etc. and take necessary corrective actions.
- Periodically (at least yearly) check electrical ground connections.

## Internal Battery

- Be aware of fire, explosion, and severe-burn hazards.
- Misuse or improper installation of the internal lithium battery can cause severe injury.
- Do not recharge, disassemble, heat above 100 °C (212 °F), solder directly to the cell, incinerate, or expose contents to water. Dispose of spent batteries properly.

WHILE EVERY ATTEMPT IS MADE TO EMBODY THE HIGHEST DEGREE OF SAFETY IN ALL CAMPBELL SCIENTIFIC PRODUCTS, THE CUSTOMER ASSUMES ALL RISK FROM ANY INJURY RESULTING FROM IMPROPER INSTALLATION, USE, OR MAINTENANCE OF TRIPODS, TOWERS, OR ATTACHMENTS TO TRIPODS AND TOWERS SUCH AS SENSORS, CROSSARMS, ENCLOSURES, ANTENNAS, ETC.



## Global Sales & Support Network

*A worldwide network to help meet your needs*



### Campbell Scientific regional offices

#### Australia

*Location:* Garbutt, QLD Australia  
*Phone:* 61.7.4401.7700  
*Email:* [info@campbellsci.com.au](mailto:info@campbellsci.com.au)  
*Website:* [www.campbellsci.com.au](http://www.campbellsci.com.au)

#### Brazil

*Location:* São Paulo, SP Brazil  
*Phone:* 11.3732.3399  
*Email:* [vendas@campbellsci.com.br](mailto:vendas@campbellsci.com.br)  
*Website:* [www.campbellsci.com.br](http://www.campbellsci.com.br)

#### Canada

*Location:* Edmonton, AB Canada  
*Phone:* 780.454.2505  
*Email:* [dataloggers@campbellsci.ca](mailto:dataloggers@campbellsci.ca)  
*Website:* [www.campbellsci.ca](http://www.campbellsci.ca)

#### China

*Location:* Beijing, P. R. China  
*Phone:* 86.10.6561.0080  
*Email:* [info@campbellsci.com.cn](mailto:info@campbellsci.com.cn)  
*Website:* [www.campbellsci.com.cn](http://www.campbellsci.com.cn)

#### Costa Rica

*Location:* San Pedro, Costa Rica  
*Phone:* 506.2280.1564  
*Email:* [info@campbellsci.cc](mailto:info@campbellsci.cc)  
*Website:* [www.campbellsci.cc](http://www.campbellsci.cc)

#### France

*Location:* Vincennes, France  
*Phone:* 0033.0.1.56.45.15.20  
*Email:* [info@campbellsci.fr](mailto:info@campbellsci.fr)  
*Website:* [www.campbellsci.fr](http://www.campbellsci.fr)

#### Germany

*Location:* Bremen, Germany  
*Phone:* 49.0.421.460974.0  
*Email:* [info@campbellsci.de](mailto:info@campbellsci.de)  
*Website:* [www.campbellsci.de](http://www.campbellsci.de)

#### India

*Location:* New Delhi, DL India  
*Phone:* 91.11.46500481.482  
*Email:* [info@campbellsci.in](mailto:info@campbellsci.in)  
*Website:* [www.campbellsci.in](http://www.campbellsci.in)

#### South Africa

*Location:* Stellenbosch, South Africa  
*Phone:* 27.21.8809960  
*Email:* [sales@campbellsci.co.za](mailto:sales@campbellsci.co.za)  
*Website:* [www.campbellsci.co.za](http://www.campbellsci.co.za)

#### Spain

*Location:* Barcelona, Spain  
*Phone:* 34.93.2323938  
*Email:* [info@campbellsci.es](mailto:info@campbellsci.es)  
*Website:* [www.campbellsci.es](http://www.campbellsci.es)

#### Thailand

*Location:* Bangkok, Thailand  
*Phone:* 66.2.719.3399  
*Email:* [info@campbellsci.asia](mailto:info@campbellsci.asia)  
*Website:* [www.campbellsci.asia](http://www.campbellsci.asia)

#### UK

*Location:* Shepshed, Loughborough, UK  
*Phone:* 44.0.1509.601141  
*Email:* [sales@campbellsci.co.uk](mailto:sales@campbellsci.co.uk)  
*Website:* [www.campbellsci.co.uk](http://www.campbellsci.co.uk)

#### USA

*Location:* Logan, UT USA  
*Phone:* 435.227.9120  
*Email:* [info@campbellsci.com](mailto:info@campbellsci.com)  
*Website:* [www.campbellsci.com](http://www.campbellsci.com)