

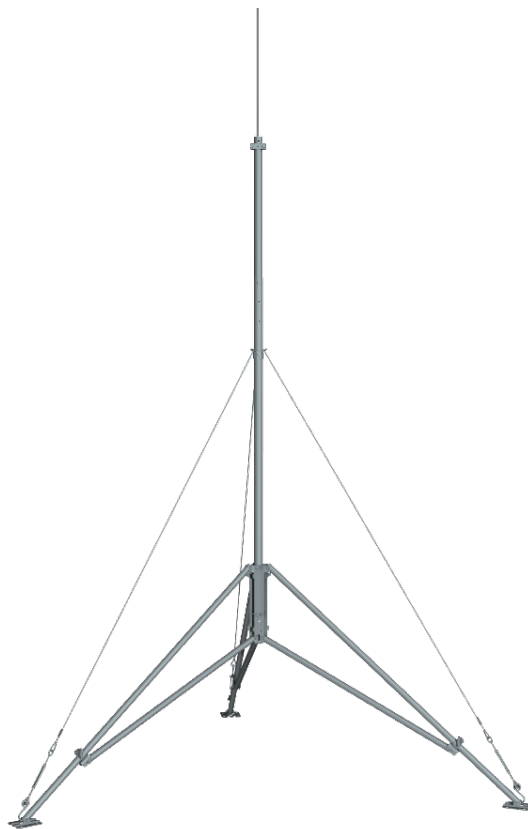

CM106B

Tripod



Revision: 10/19

Copyright © 2005 – 2019
Campbell Scientific, Inc.



Limited Warranty

“Products manufactured by CSI are warranted by CSI to be free from defects in materials and workmanship under normal use and service for twelve months from the date of shipment unless otherwise specified in the corresponding product manual. (Product manuals are available for review online at www.campbellsci.com.) Products not manufactured by CSI, but that are resold by CSI, are warranted only to the limits extended by the original manufacturer. Batteries, fine-wire thermocouples, desiccant, and other consumables have no warranty. CSI’s obligation under this warranty is limited to repairing or replacing (at CSI’s option) defective Products, which shall be the sole and exclusive remedy under this warranty. The Customer assumes all costs of removing, reinstalling, and shipping defective Products to CSI. CSI will return such Products by surface carrier prepaid within the continental United States of America. To all other locations, CSI will return such Products best way CIP (port of entry) per Incoterms ® 2010. This warranty shall not apply to any Products which have been subjected to modification, misuse, neglect, improper service, accidents of nature, or shipping damage. This warranty is in lieu of all other warranties, expressed or implied. The warranty for installation services performed by CSI such as programming to customer specifications, electrical connections to Products manufactured by CSI, and Product specific training, is part of CSI’s product warranty. **CSI EXPRESSLY DISCLAIMS AND EXCLUDES ANY IMPLIED WARRANTIES OF MERCHANTABILITY OR FITNESS FOR A PARTICULAR PURPOSE. CSI hereby disclaims, to the fullest extent allowed by applicable law, any and all warranties and conditions with respect to the Products, whether express, implied or statutory, other than those expressly provided herein.**”

Assistance

Products may not be returned without prior authorization. The following contact information is for US and international customers residing in countries served by Campbell Scientific, Inc. directly. Affiliate companies handle repairs for customers within their territories. Please visit www.campbellsci.com to determine which Campbell Scientific company serves your country.

To obtain a Returned Materials Authorization (RMA) number, contact CAMPBELL SCIENTIFIC, INC., phone (435) 227-9000. Please write the issued RMA number clearly on the outside of the shipping container. Campbell Scientific's shipping address is:

CAMPBELL SCIENTIFIC, INC.

RMA# _____
815 West 1800 North
Logan, Utah 84321-1784

For all returns, the customer must fill out a "Statement of Product Cleanliness and Decontamination" form and comply with the requirements specified in it. The form is available from our website at www.campbellsci.com/repair. A completed form must be either emailed to repair@campbellsci.com or faxed to (435) 227-9106. Campbell Scientific is unable to process any returns until we receive this form. If the form is not received within three days of product receipt or is incomplete, the product will be returned to the customer at the customer's expense. Campbell Scientific reserves the right to refuse service on products that were exposed to contaminants that may cause health or safety concerns for our employees.

Safety

DANGER — MANY HAZARDS ARE ASSOCIATED WITH INSTALLING, USING, MAINTAINING, AND WORKING ON OR AROUND **TRIPODS, TOWERS, AND ANY ATTACHMENTS TO TRIPODS AND TOWERS SUCH AS SENSORS, CROSSARMS, ENCLOSURES, ANTENNAS, ETC.** FAILURE TO PROPERLY AND COMPLETELY ASSEMBLE, INSTALL, OPERATE, USE, AND MAINTAIN TRIPODS, TOWERS, AND ATTACHMENTS, AND FAILURE TO HEED WARNINGS, INCREASES THE RISK OF DEATH, ACCIDENT, SERIOUS INJURY, PROPERTY DAMAGE, AND PRODUCT FAILURE. TAKE ALL REASONABLE PRECAUTIONS TO AVOID THESE HAZARDS. CHECK WITH YOUR ORGANIZATION'S SAFETY COORDINATOR (OR POLICY) FOR PROCEDURES AND REQUIRED PROTECTIVE EQUIPMENT PRIOR TO PERFORMING ANY WORK.

Use tripods, towers, and attachments to tripods and towers only for purposes for which they are designed. Do not exceed design limits. Be familiar and comply with all instructions provided in product manuals. Manuals are available at www.campbellsci.com or by telephoning (435) 227-9000 (USA). You are responsible for conformance with governing codes and regulations, including safety regulations, and the integrity and location of structures or land to which towers, tripods, and any attachments are attached. Installation sites should be evaluated and approved by a qualified engineer. If questions or concerns arise regarding installation, use, or maintenance of tripods, towers, attachments, or electrical connections, consult with a licensed and qualified engineer or electrician.

General

- Prior to performing site or installation work, obtain required approvals and permits. Comply with all governing structure-height regulations, such as those of the FAA in the USA.
- Use only qualified personnel for installation, use, and maintenance of tripods and towers, and any attachments to tripods and towers. The use of licensed and qualified contractors is highly recommended.
- Read all applicable instructions carefully and understand procedures thoroughly before beginning work.
- Wear a **hardhat** and **eye protection**, and take **other appropriate safety precautions** while working on or around tripods and towers.
- **Do not climb** tripods or towers at any time, and prohibit climbing by other persons. Take reasonable precautions to secure tripod and tower sites from trespassers.
- Use only manufacturer recommended parts, materials, and tools.

Utility and Electrical

- **You can be killed** or sustain serious bodily injury if the tripod, tower, or attachments you are installing, constructing, using, or maintaining, or a tool, stake, or anchor, come in **contact with overhead or underground utility lines**.
- Maintain a distance of at least one-and-one-half times structure height, 20 feet, or the distance required by applicable law, **whichever is greater**, between overhead utility lines and the structure (tripod, tower, attachments, or tools).
- Prior to performing site or installation work, inform all utility companies and have all underground utilities marked.
- Comply with all electrical codes. Electrical equipment and related grounding devices should be installed by a licensed and qualified electrician.

Elevated Work and Weather

- Exercise extreme caution when performing elevated work.
- Use appropriate equipment and safety practices.
- During installation and maintenance, keep tower and tripod sites clear of un-trained or non-essential personnel. Take precautions to prevent elevated tools and objects from dropping.
- Do not perform any work in inclement weather, including wind, rain, snow, lightning, etc.

Maintenance

- Periodically (at least yearly) check for wear and damage, including corrosion, stress cracks, frayed cables, loose cable clamps, cable tightness, etc. and take necessary corrective actions.
- Periodically (at least yearly) check electrical ground connections.

WHILE EVERY ATTEMPT IS MADE TO EMBODY THE HIGHEST DEGREE OF SAFETY IN ALL CAMPBELL SCIENTIFIC PRODUCTS, THE CUSTOMER ASSUMES ALL RISK FROM ANY INJURY RESULTING FROM IMPROPER INSTALLATION, USE, OR MAINTENANCE OF TRIPODS, TOWERS, OR ATTACHMENTS TO TRIPODS AND TOWERS SUCH AS SENSORS, CROSSARMS, ENCLOSURES, ANTENNAS, ETC.

Table of Contents

PDF viewers: These page numbers refer to the printed version of this document. Use the PDF reader bookmarks tab for links to specific sections.

1. Introduction.....	1
2. Precautions	2
3. Initial Inspection	2
3.1 Inspect Packaging.....	2
3.2 Tripod Components.....	2
3.3 Tools List (for tripod, mast, enclosures, and crossarms).....	4
4. Overview	4
5. Specifications	5
6. Installation	6
6.1 Tripod Installation.....	6
6.1.1 Tripod Base.....	6
6.1.1.1 Mounting on a Relatively Flat Area	7
6.1.1.2 Mounting on an Incline	7
6.1.2 Mast	8
6.1.3 Installing the Optional Guy Kit.....	10
6.1.4 Staking the Tripod Feet.....	12
6.1.5 Tripod Grounding	13
6.1.6 Crossarm Attachment.....	15
6.1.7 Enclosure Attachment	15
6.1.7.1 Enclosure Mounting to Tripod Mast	15
6.1.7.2 Enclosure Mounting to Tripod Leg	16
6.2 Mounting Brackets	18
6.2.1 CM210 Crossarm Mounting Kit	18
6.2.2 CM216 Mast Mounting Kit.....	19
6.2.3 CM220 Right Angle Mounting Kit	20
6.2.4 CMB200 Crossarm Brace Kit	21
6.2.4.1 Overview	21
6.2.4.2 Components.....	21
6.2.4.3 Assembly	22
6.3 Center Duckbill Anchor Kit	24
6.3.1 Installation.....	24

Appendix

A. CM106B Allowable Wind Speeds.....	A-1
---	------------

Figures

1-1. Typical tripod-based weather station1
 3-1. Tripod components.....3
 4-1. CM106B tripod with lightning rod and guy wires4
 6-1. Tripod leg, leg clamp components6
 6-2. Installation on an incline7
 6-3. Tripod mast and insert.....8
 6-4. Mast attachment to tripod base.....9
 6-5. Guy kit.....10
 6-6. Leg attachment11
 6-7. Staking the tripod feet12
 6-8. Ground rod and clamp.....13
 6-9. Lightning rod.....14
 6-10. CM204 Crossarm15
 6-11. Enclosure with the –MM bracket16
 6-12. Enclosure with the –LM bracket17
 6-13. CM210 Crossarm Mounting Kit (shown with user-supplied pipe)18
 6-14. CM216 Mast Mounting Kit.....19
 6-15. CM220 Right Angle Mounting Kit20
 6-16. CMB200 Crossarm Brace Kit21
 6-17. CMB200 components.....22
 6-18. Bracket selection23
 6-19. Center Duckbill Anchor Kit24

Table

6-1. Bracket Requirements23

CM106B Tripod

1. Introduction

The CM106B is a general purpose tripod that can be used for mounting sensors, solar panels, antennas, and instrument enclosures. FIGURE 1-1 shows the CM106B being used in a typical weather station configuration.

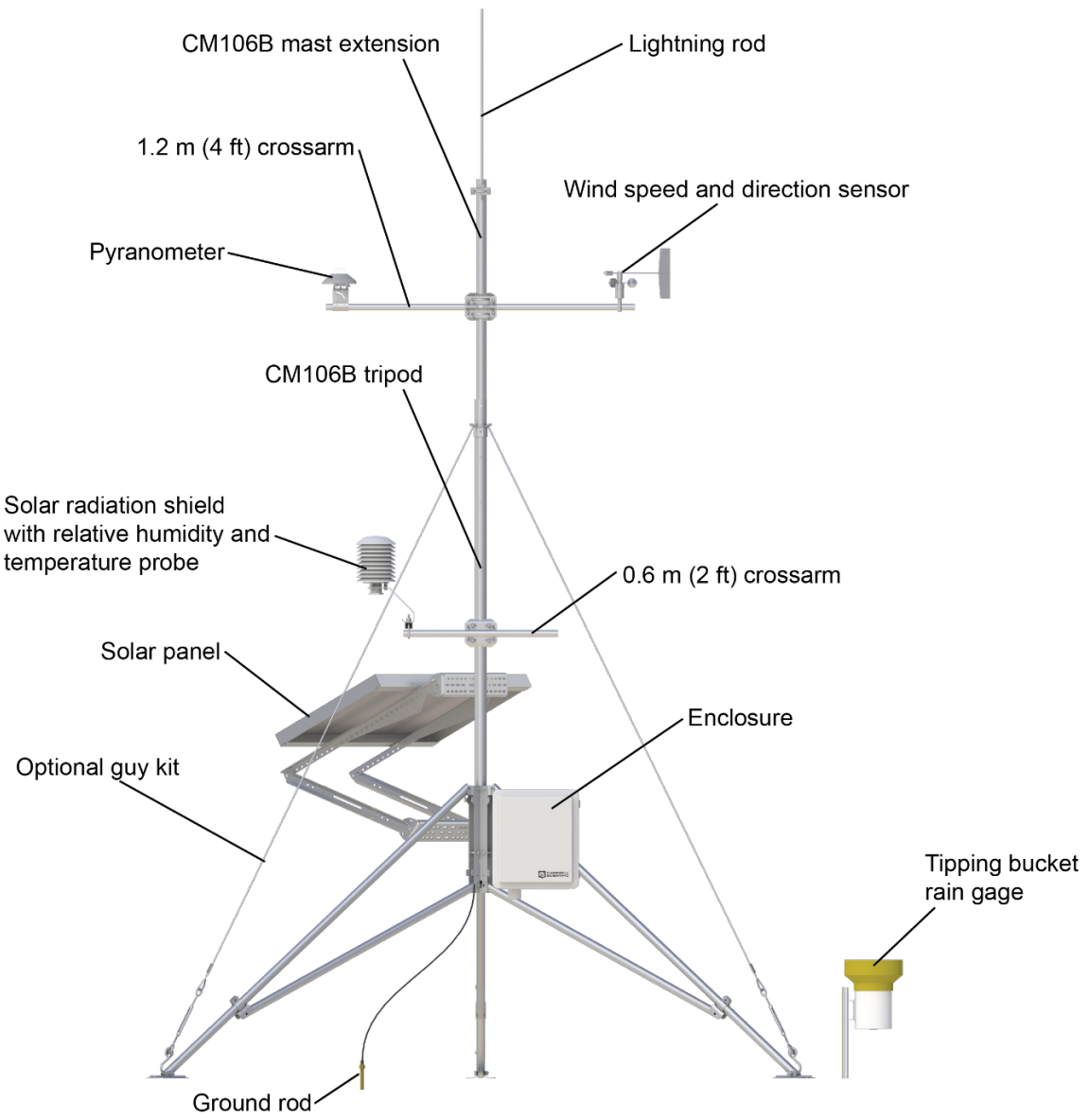

FIGURE 1-1. Typical tripod-based weather station

2. Precautions

- READ AND UNDERSTAND the *Safety* section at the front of this manual.
- WARNING — Ensure structural integrity during setup and weather extremes to minimize the chance of damaging the tripod or instruments. Read all instructions carefully. Once the tripod is in full vertical position, securely fasten it to the ground using ground spikes.
- WARNING — For installations where soil structure is questionable or the tripod may experience high wind loads, concrete footings for the tripod feet and guy anchors should be considered.
- Keep the bottom of the tripod legs free of soil, ice, and debris to prevent trapping any moisture inside or around the legs.

3. Initial Inspection

3.1 Inspect Packaging

Upon receiving the CM106B, inspect the packaging and contents for damage. Claims for shipping damage must be filed with the shipping company.

Locate the packing slip for the order and compare the items listed on the packing slip to the items that were actually shipped. Report any discrepancies to Campbell Scientific.

3.2 Tripod Components

FIGURE 3-1 shows the tripod components. The tripod base is packaged with the mast, mast extension, ground rod, lightning rod, and (6) stakes. The ground rod clamp, lightning rod clamp, cable ties, and ground wires are enclosed in a bag. The optional guy kit is packaged separately.

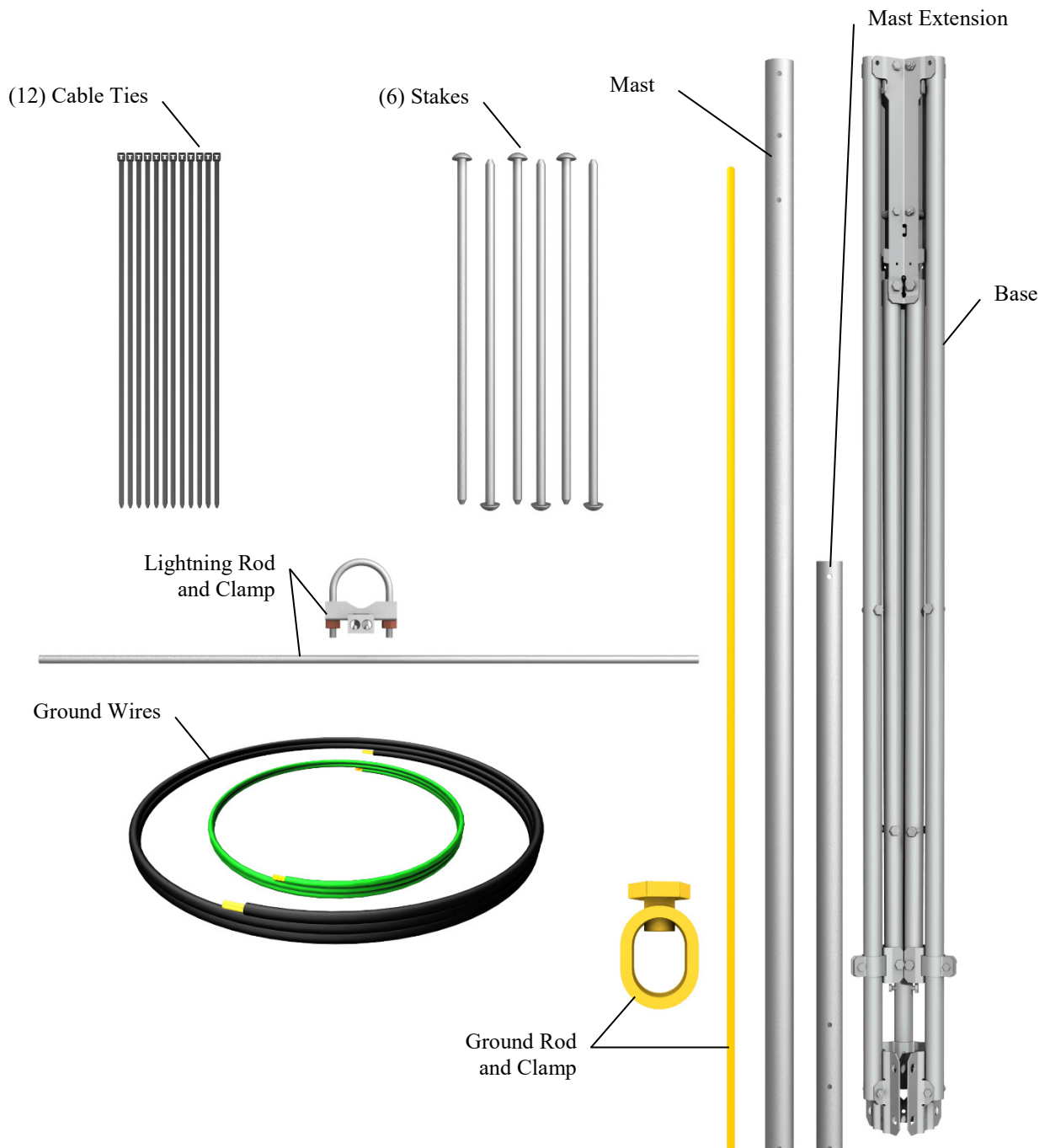

FIGURE 3-1. Tripod components

3.3 Tools List (for tripod, mast, enclosures, and crossarms)

- 1/2-in and 7/16-in open end wrenches
- adjustable wrench
- Phillips head screw drivers (medium, small)
- Straight bit screwdrivers (large, medium)
- 30 cm (12 in) torpedo level
- side-cut pliers
- pencil
- tape measure
- compass and site declination angle
- shovel
- sledge hammer (for driving ground rod and stakes)
- step ladder

4. Overview

The CM106B (FIGURE 4-1) is constructed from galvanized steel, with individually adjustable legs that allow installation over uneven terrain.

The CM106B includes lightning and ground rods, ground cables, UV resistant cable ties, and stakes for securing the tripod feet to the ground. An optional guy kit is recommended for sites that experience high wind speeds (see Section 5, Specifications (p. 5)). Instrument enclosures can be purchased with mounting brackets that attach to either the mast or leg section as shown in Section 6.1.7, *Enclosure Attachment* (p. 15).

The CM106B can be used for a variety of applications. For meteorological stations, sensors are mounted to the tripod using mounting brackets appropriate for the model of sensor. For non-meteorological applications, the tripod can be used to mount instrument enclosures, solar panels, junction boxes, or antennas.

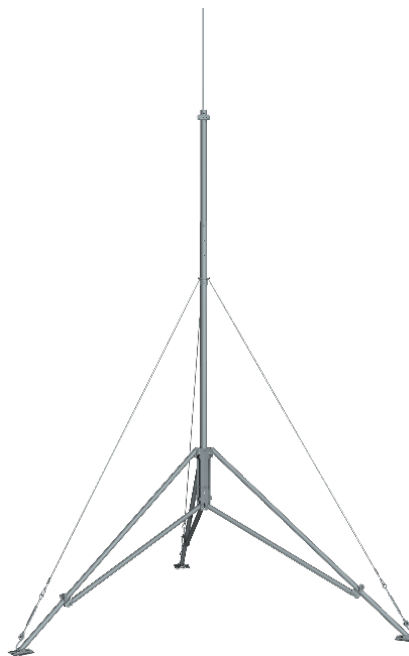

FIGURE 4-1. CM106B tripod with lightning rod and guy wires

5. Specifications

Mast Height

Upper Mast Retracted: 2.1 m (7 ft) to 2.8 m (9.3 ft)
Upper Mast Extended: 3 m (10 ft) to 3.7 m (12.3 ft)

Vertical Load Limit: 200 kg (440 lb)

Mast Outer Diameter

Main Lower Mast: 48 mm (1.90 in)
Retractable Upper: 44 mm (1.74 in)

Base Diameter: 2.7 m (8.7 ft) to 3.5 m (11.5 ft)

Leveling Adjustment: Slide leg clamp on each leg, adjust individually

Leg Base: 11.4 x 14.0 cm (4.5 x 5.5 in) with four 1.6 cm (0.62 in) holes for stakes

Portability: Collapsible to 20.3 cm (8 in) diameter by 18.3 m (6 ft) length

Weight with Mast: 24.5 kg (54 lb)

Maximum Slope Angle: 45° or 100% grade (FIGURE 6-2)

Allowable Wind Speeds*

Tripod Configuration	Sustained Wind	Wind Gust
Mast Extended, Unguyed	28 m s ⁻¹ (62 mph)	36 m s ⁻¹ (81 mph)
Mast Retracted, Unguyed	36 m s ⁻¹ (80 mph)	46 m s ⁻¹ (104 mph)
Mast Extended, Guyed	45 m s ⁻¹ (102 mph)	59 m s ⁻¹ (132 mph)
Mast Retracted, Guyed	55 m s ⁻¹ (122 mph)	71 m s ⁻¹ (159 mph)

*Allowable wind speed values assume:

- Sensors (effective area = 42.7 cm² (1.4 ft²)) at top of mast
- Solar panel 26.7 x 41.9 cm (10.5 x 16.5 in) at mast base
- ENC14/16 mounted to leg
- Guy wires attached to mast at 1.16 m (3.8 ft) above tripod body
- Adequate ground anchors (stakes alone may not resist foot vertical pullout force)
- See Appendix A, CM106B Allowable Wind Speeds (p. A-1), for more information on maximum allowable wind speeds.

6. Installation

6.1 Tripod Installation

This section gives the procedure for assembling the CM106B. Campbell Scientific has also produced a series of videos covering the assembly of the tripod and attaching various components. To view these videos, visit www.campbellsci.com/CM106B .

6.1.1 Tripod Base

For a video demonstrating how to assemble a tripod, see www.campbellsci.com/videos/tripod .

The tripod base has three independently adjustable legs allowing the tripod to be installed over non-level terrain.

Prepare the area where the tripod will be installed. The tripod requires an area approximately 2.7 to 3.5 m (8.7 to 11.5 ft) in diameter. Natural vegetation and the ground surface should be disturbed as little as possible, but brush and tall weeds should be removed.

Stand the tripod base up on end, and rotate the feet perpendicular to the legs. Each leg has a leg clamp and clamping bolt as shown in FIGURE 6-1.

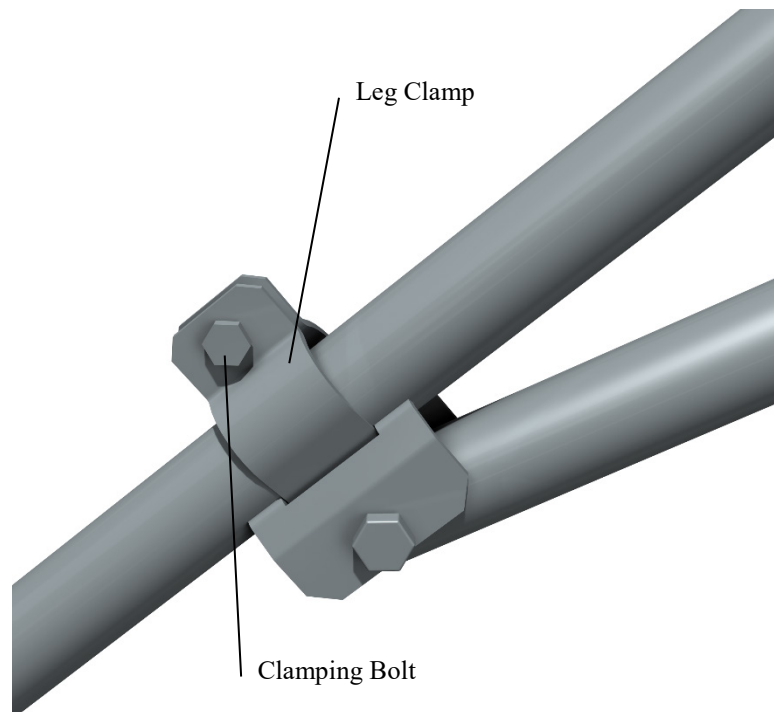

FIGURE 6-1. Tripod leg, leg clamp components

6.1.1.1 Mounting on a Relatively Flat Area

Loosen the tension bolt and extend each leg. With the legs extended, orient the tripod so that one of the legs points South (assuming the instrument enclosure with –MM Mast Mount bracket will face North). If the instrument enclosure has the –LM Leg Mount bracket, orient the tripod so the enclosure will mount to one of the three leg mount positions on the tripod, facing the desired direction. The tripod is typically plumbed after the mast has been installed, as described in Section 6.1.2, *Mast* (p. 8).

6.1.1.2 Mounting on an Incline

Loosen the tension bolt and extend each leg. With the legs extended, orient the tripod so that one leg points downhill and the other two legs point uphill. The tripod is more stable with only one leg pointed downhill because the mast is closer to the center of the footprint (see FIGURE 6-2).

The tripod is typically plumbed after the mast has been installed, as described in Section 6.1.2, *Mast* (p. 8).

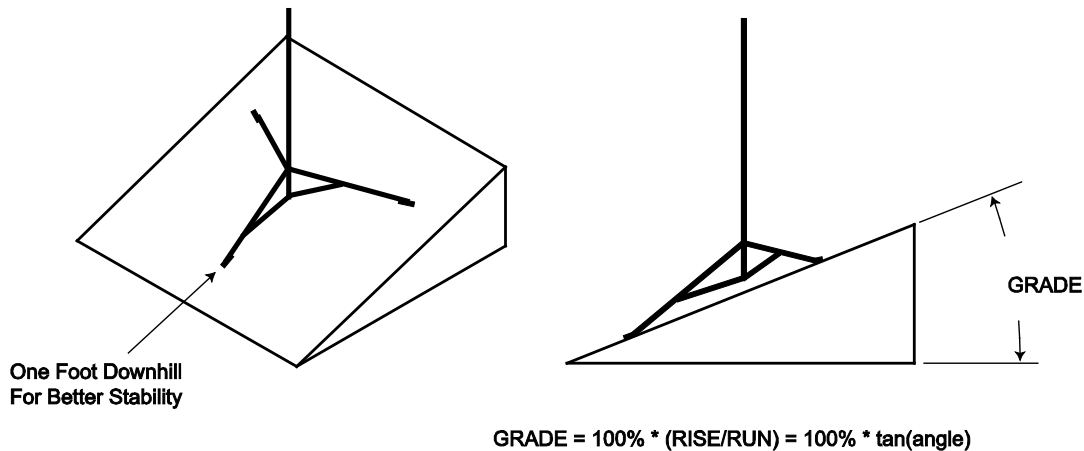

FIGURE 6-2. Installation on an incline

6.1.2 Mast

The CM106B includes a mast extension that can be fully extended for a 3 m (10 ft) height, or partially extended for a 2.1 m (7 ft) height. Remove the bolts in the extension, align the holes in the insert with holes in the mast, and install the four bolts previously removed. Two additional holes make it possible for the extension to extend 20, 30, 51, 61, or 71 cm (8, 12, 20, 24, or 28 in) above the mast, depending on which end is inserted in the mast.

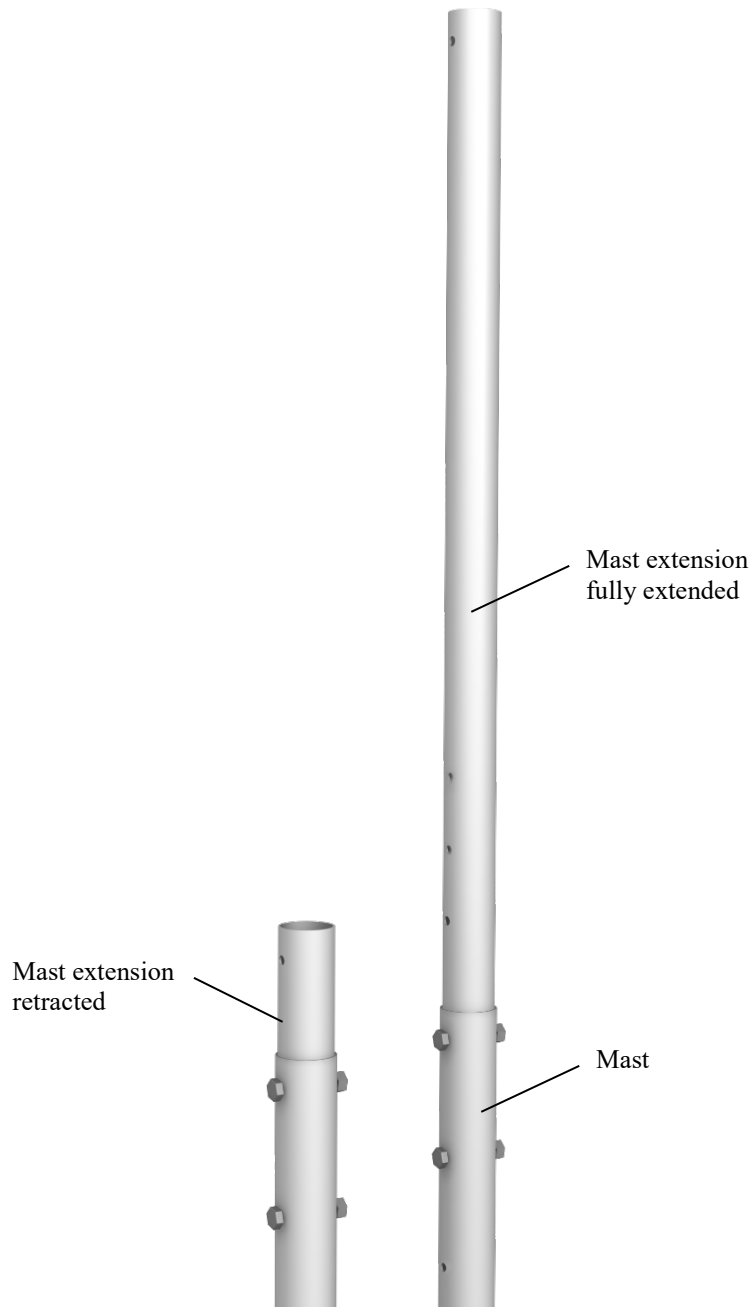

FIGURE 6-3. Tripod mast and insert

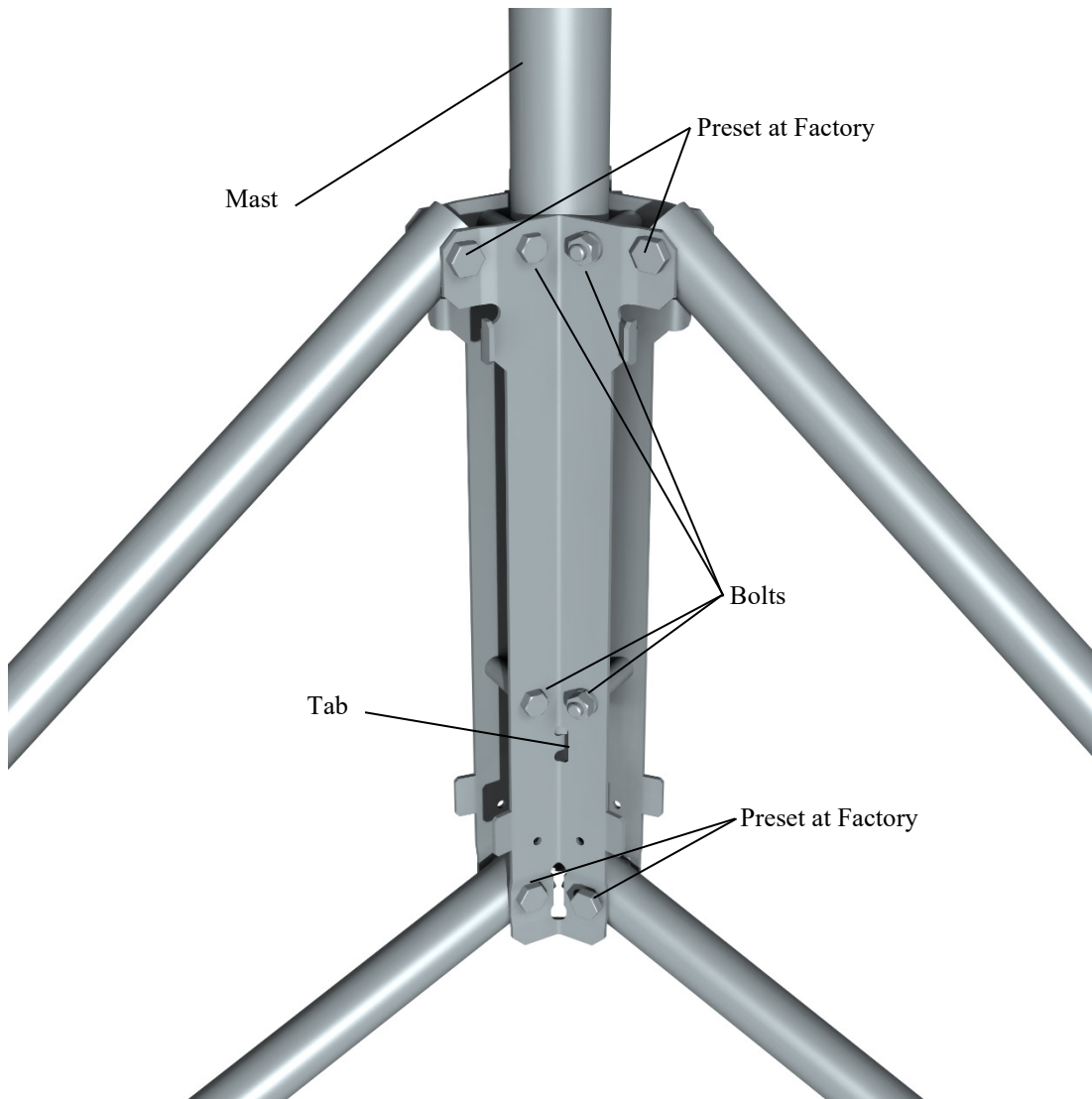



FIGURE 6-4. Mast attachment to tripod base

Loosen the six bolts on the tripod base. FIGURE 6-4 shows the location of four of these bolts. The remaining bolts are in the same position on the third tripod leg. Slide the mast into the tripod base, making sure that it extends below the lower bolts and rests on the tabs. Tighten the six bolts to secure the mast.

Plumb the tripod by adjusting the northeast and south facing legs. With a level on the East side of the mast, adjust the Northeast leg for plumb. With the level on the South side of the mast, adjust the South leg for plumb. Tighten the tension bolts after the adjustments have been made.

6.1.3 Installing the Optional Guy Kit

For a video showing how to attach the optional guy wire kit to a tripod, see www.campbellsci.com/videos/tripod3 .

The CM106B Guy Kit can be ordered separately for areas that experience high wind speeds (Section 5, *Specifications (p. 5)*). Install the guy ring collar on the mast as shown in FIGURE 6-5. Attach the three guy wires to the guy ring and slide the ring over the mast so the collar rests on top of the guy ring collar.

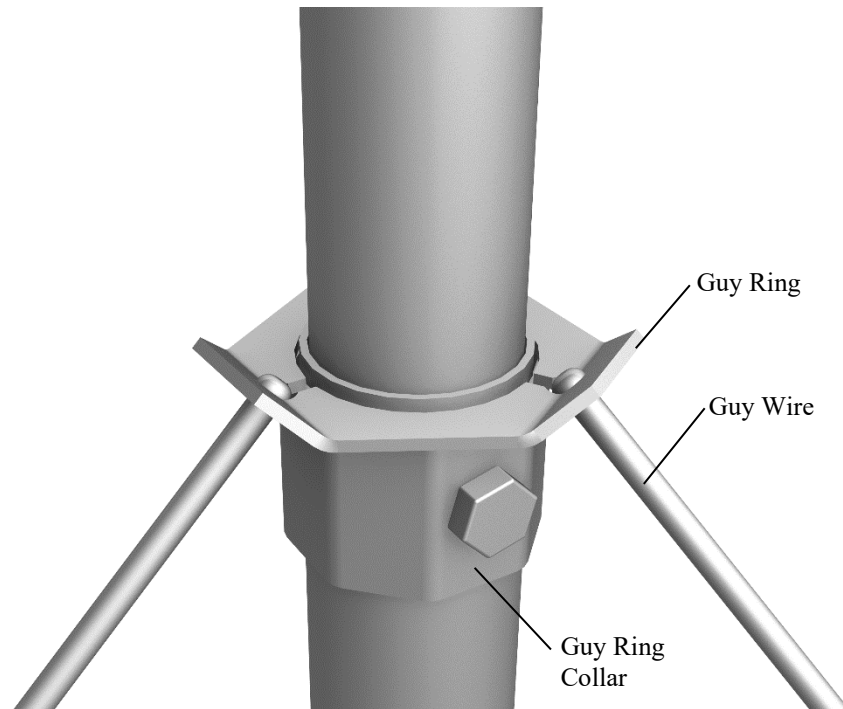

FIGURE 6-5. Guy kit

On the end of each guy wire is a case and hardware to attach to the turnbuckles. Unscrew the turnbuckles so that only 1.2 cm (0.5 in) of thread extends beyond the inside of the turnbuckle body. Attach the case and turnbuckle to the tripod leg as shown in FIGURE 6-6. Loosen the two clamp nuts, and remove the slack in the guy wire by feeding the load end of the guy wire through the case while pulling up on the free end.

After the slack has been removed from the guy wires, tighten the clamp nuts, and then tighten the turnbuckles to the desired tension.

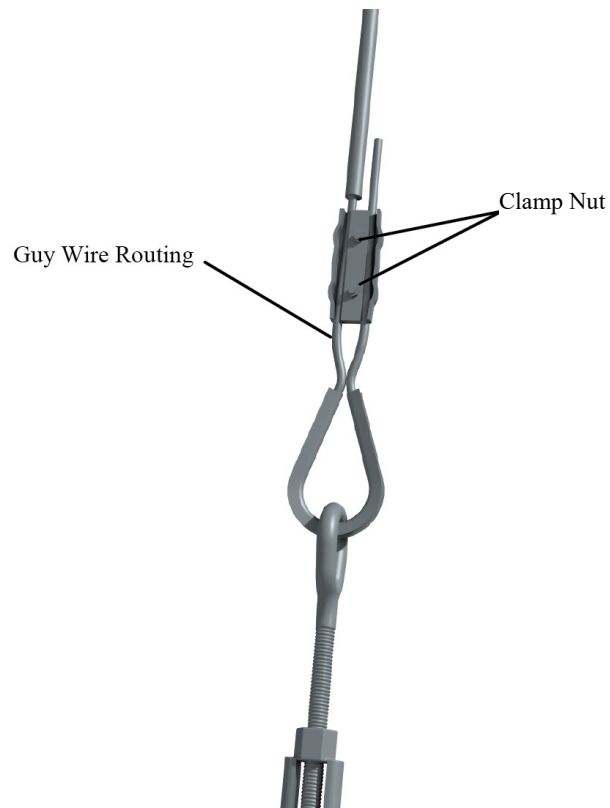
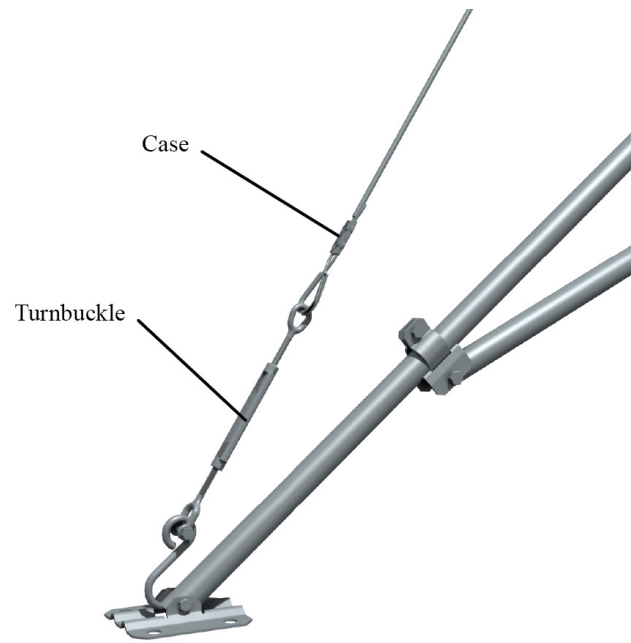

FIGURE 6-6. Leg attachment

6.1.4 Staking the Tripod Feet

Six stakes are provided for securing the tripod feet to the ground. Drive two stakes through holes in each foot at an angle as shown in FIGURE 6-7.

Stakes may not be adequate depending on soil structure, maximum wind speeds experienced at the site, mast height, or wind load from the instrumentation. For questionable situations, additional stakes or even concrete footings for the tripod feet and guy anchors should be considered.

CAUTION

Keep the bottom of the tripod legs free of soil, ice, and debris to prevent trapping any moisture inside or around the legs.

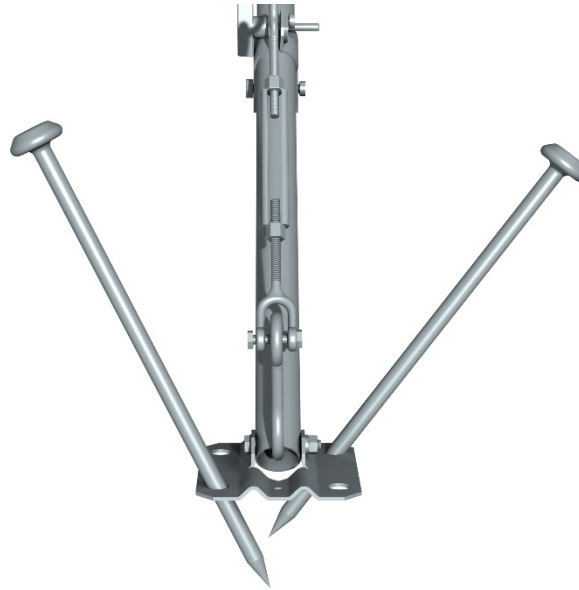

FIGURE 6-7. Staking the tripod feet

6.1.5 Tripod Grounding

Place the clamp over the ground rod and drive the rod (close to the center of the tripod) using a sledge hammer or fence post driver. Strip 1.2 cm (0.5 in) of insulation from both ends of the black 4 AWG ground wire. Insert one end of the ground wire into the clamp and ground rod and tighten the bolt on the clamp. Attach the other end of the ground wire to the lug on the tripod base as shown in FIGURE 6-8.

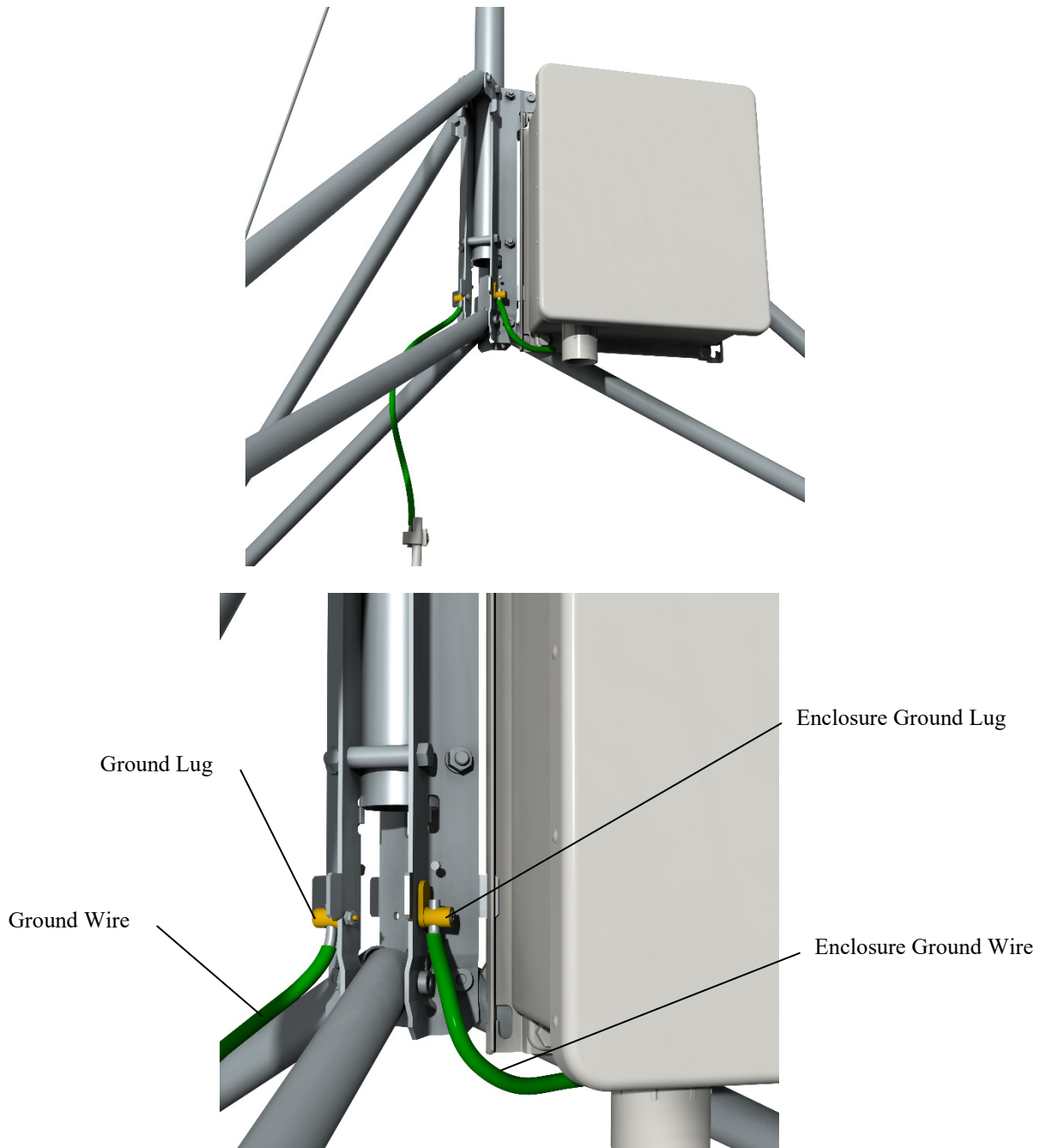

FIGURE 6-8. Ground rod and clamp

Strip 1.2 cm (0.5 in) of insulation from the ends of the green 12 AWG wire. Attach one end of the wire to the tripod ground lug, and the other end to the enclosure ground lug as shown in FIGURE 6-8.

Mount the lightning rod and clamp to the tripod mast with pointed tip up, and notch at bottom (FIGURE 6-9).

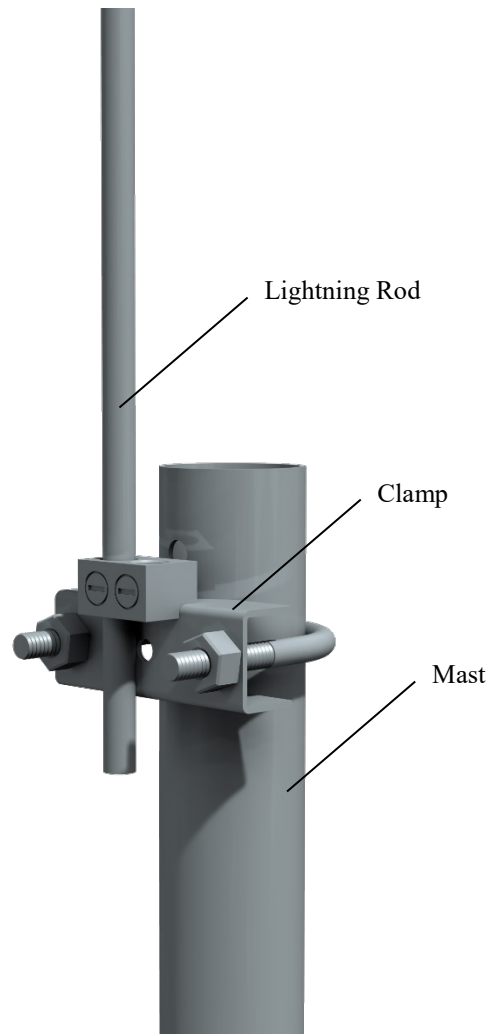



FIGURE 6-9. Lightning rod

6.1.6 Crossarm Attachment

For a video demonstrating how to attach a crossarm to a tripod, see www.campbellsci.com/videos/tripod5 .

Attach the CM202 (0.6 m, 2 ft), CM204 (1.2 m, 4 ft), or CM206 (1.8 m, 6 ft) crossarm to the tripod mast as shown in FIGURE 6-10. For wind sensors, the crossarm should be approximately 2.6 m (103 in) above the ground for a 3 m mounting height, or 1.6 m (64 in) for a 2 m mounting height. Typically, the crossarm is oriented East/West for wind sensors, North/South for pyranometers.

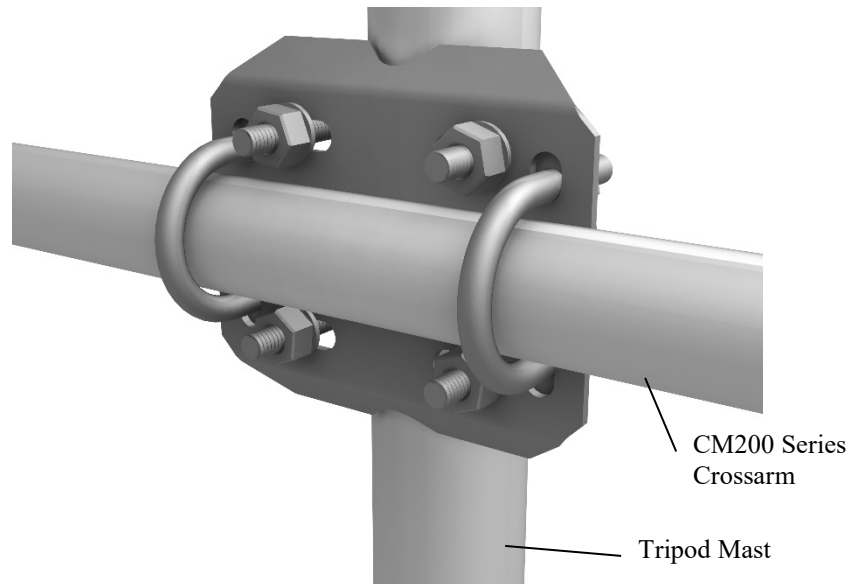



FIGURE 6-10. CM204 Crossarm

6.1.7 Enclosure Attachment

The ENC10/12, ENC12/14, ENC14/16, and ENC16/18 enclosures can be ordered with mounting brackets for the CM106B tripod. All enclosure models can be mounted to the tripod mast (above the legs) with the –MM Mast Mount bracket option. The –LM Leg Mount bracket option allows all enclosure models to be mounted to the tripod base. Two enclosures with the –LM brackets can be mounted in a “back to back” configuration.

6.1.7.1 Enclosure Mounting to Tripod Mast

For a video showing how to mount an enclosure to the tripod mast, see www.campbellsci.com/videos/tripod4 .

An enclosure ordered with the –MM bracket has a three-piece top and bottom brackets with a U-bolt for each bracket.

Attach an enclosure with the –MM mounting bracket to the tripod mast as follows:

Remove the U-bolts, washers, and nuts from the brackets.

Position the enclosure against the tripod mast (North side recommended).

Install the U-bolts, flat washers, lock washers, and nuts (FIGURE 6-11). Tighten the nuts until the lock washers are compressed.

Route the 14 AWG wire from the ground lug on the bottom side of the enclosure to the ground lug on the base of the tripod (FIGURE 6-8). Strip 1.2 cm (0.5 in) of insulation from each end of the wire. Insert wire ends into the ground lugs and tighten.

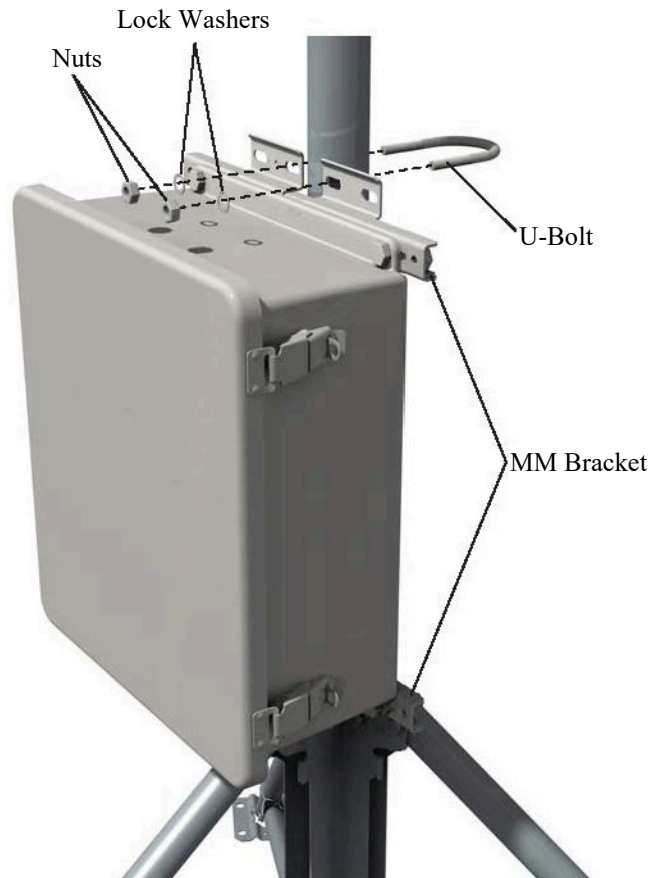



FIGURE 6-11. Enclosure with the –MM bracket

6.1.7.2 Enclosure Mounting to Tripod Leg

For a video showing how to mount an enclosure to a tripod leg, see www.campbellsci.com/videos/tripod9 .

An enclosure ordered with the –LM bracket has a bracket on each side of the enclosure, and a U-bolt bracket for securing the enclosure to a tripod leg.

Attach an enclosure with the –LM mounting bracket to the tripod base as follows:

Slide the keyhole notch in upper corner of the –LM bracket over the extended hook located on the tripod base as shown in FIGURE 6-12, and engage the notch in the lower corner of the –LM bracket with the enclosure tab. There are six places on the tripod base with provisions for mounting enclosures with the –LM brackets.

Remove the washers, nuts, and U-bolt from the U-bolt bracket. Install the bracket as shown in FIGURE 6-12 (top). Tighten the nuts on the U-bolt until the lock washers are compressed.

Route the 14 AWG wire from the ground lug on the bottom side of the enclosure to the ground lug on the base of the tripod (FIGURE 6-8). Strip 1.2 cm (0.5 in) of insulation from each end of the wire. Insert wire ends into the ground lugs and tighten.

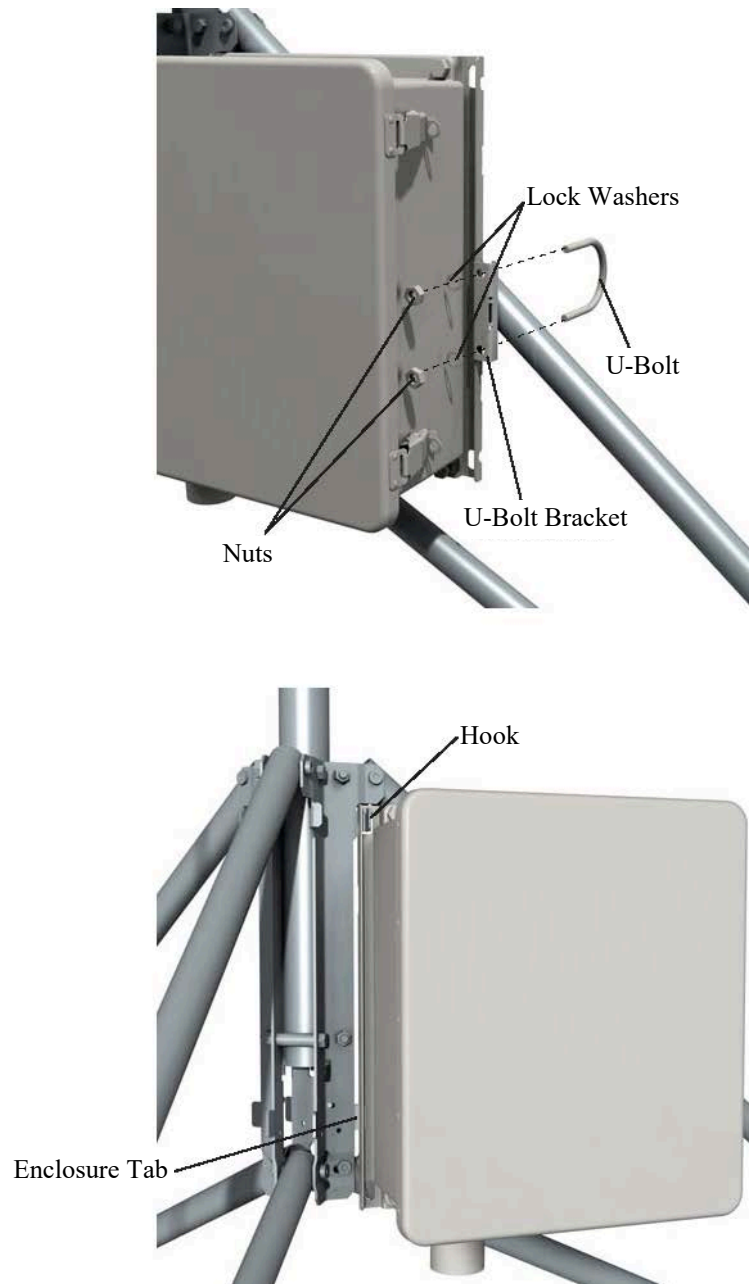

FIGURE 6-12. Enclosure with the -LM bracket

6.2 Mounting Brackets

Mounting brackets covered in this section have U-bolts that attach to vertical and/or horizontal pipes with the following ranges of outside diameters:

	inches	mm	Nominal Pipe Size (inches)
3.8 cm (1.5 in) U-bolt	1.0 – 1.5	25.4 – 38.1	3/4 – 1
5.1 cm (2 in) U-bolt	1.3 – 2.1	33.0 – 53.3	1 – 1 1/2
5.1 cm (2 in) U-bolt with plastic V-block	1.0 – 2.1	25.4 – 53.3	3/4 – 1 1/2

Some of the brackets (for example, the CM210) include 3.8 cm and 5.1 cm (1.5 in and 2 in) U-bolts to extend the range of pipe diameters that the bracket can accommodate. Brackets with holes for a 3.8 cm (1.5 in) U-bolt will accept a user-supplied 4.4 cm (1.75 in) U-bolt.

6.2.1 CM210 Crossarm Mounting Kit

CM200 series crossarms include a CM210 bracket as shown in FIGURE 6-13. The CM210 can be ordered separately to attach a user-supplied pipe (2.5 to 3.8 cm (1.0 to 1.5 in) OD) to a mast or tower leg (2.5 to 5.3 cm (1.0 to 2.1 in) OD), or to attach a crossarm to two tower legs.

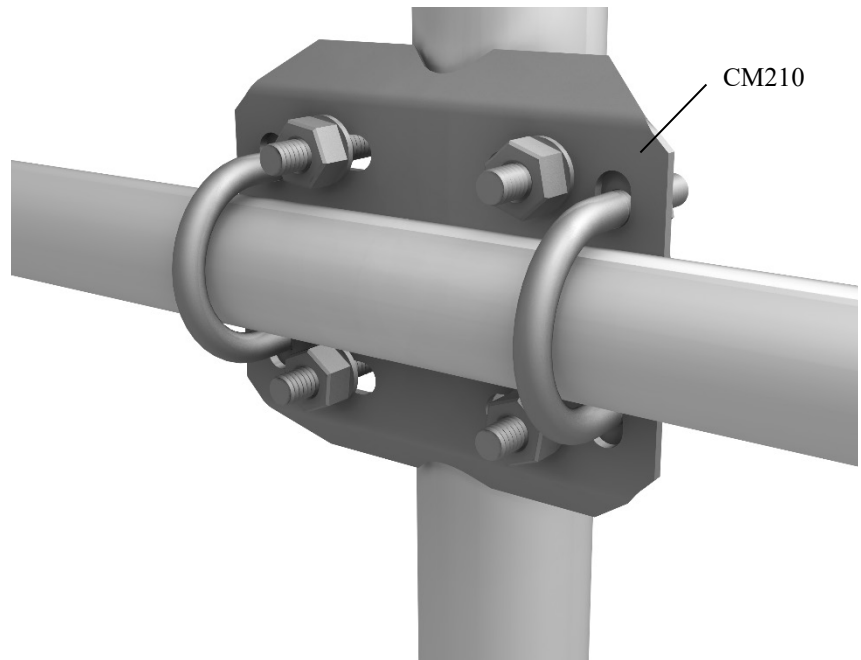

FIGURE 6-13. CM210 Crossarm Mounting Kit (shown with user-supplied pipe)

6.2.2 CM216 Mast Mounting Kit

The CM216 attaches to the top of the mast, and provides a 1.9 cm (0.75 in) or 2.5 cm (1 in) mounting pipe (2.7 cm or 3.4 cm (1.05 in or 1.32 in) OD) that extends 10 cm (4 in) above the mast, as shown in FIGURE 6-14.



FIGURE 6-14. CM216 Mast Mounting Kit

6.2.3 CM220 Right Angle Mounting Kit

The CM220 attaches a vertical pipe (2.5 to 3.8 cm (1.0 to 1.5 in) OD) to the CM200-series crossarms or horizontal pipe (2.5 to 3.8 cm (1.0 to 1.5 in) OD) as shown in FIGURE 6-15.



FIGURE 6-15. CM220 Right Angle Mounting Kit

6.2.4 CMB200 Crossarm Brace Kit

6.2.4.1 Overview

The CMB200 Crossarm Brace Kit (FIGURE 6-16) is designed to provide additional stability to crossarms mounted on Campbell Scientific tripods and towers. It provides additional support for crossarms with heavier sensor loads, and added stability in high winds.

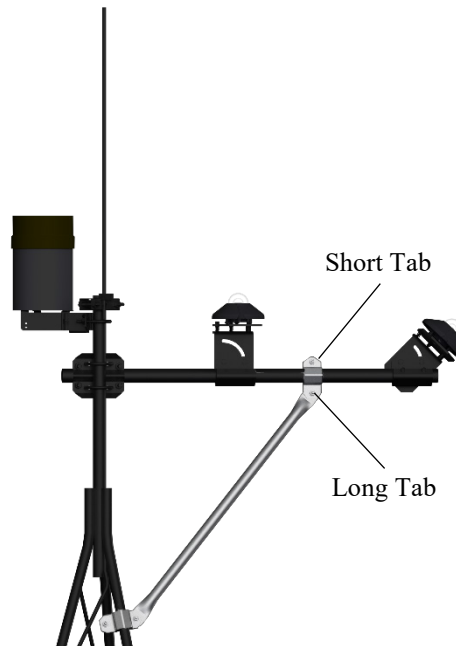

FIGURE 6-16. CMB200 Crossarm Brace Kit

6.2.4.2 Components

The CMB200 ships with the following components (FIGURE 6-17):

- (1) Brace Arm
- (2) Small bracket
- (2) Medium bracket
- (2) Large bracket
- (4) 1/4-20 x 1-inch bolt
- (8) 1/4 flat washer
- (4) 1/4 lock washer
- (4) 1/4-20 nut

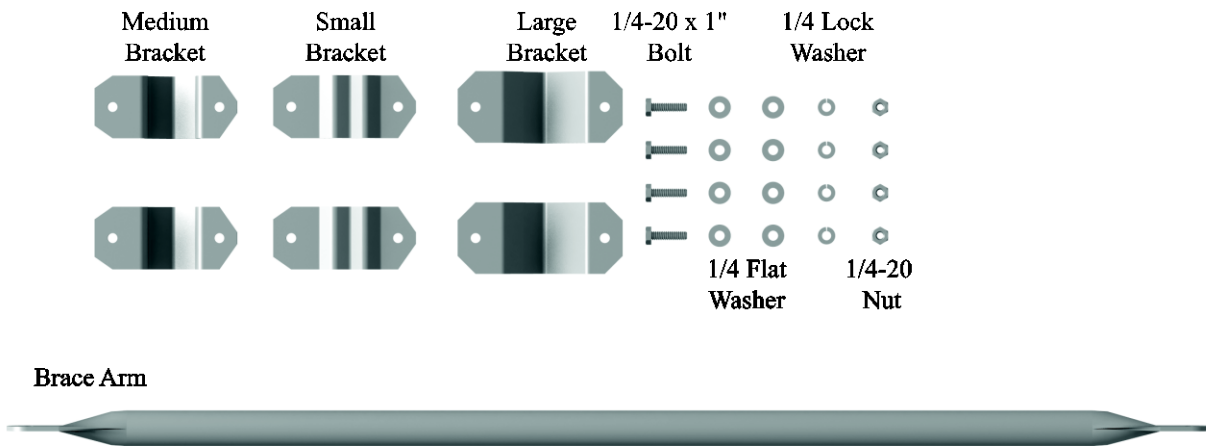

FIGURE 6-17. CMB200 components

6.2.4.3 Assembly

1. Consult FIGURE 6-18 and TABLE 6-1 to determine which brackets are needed at either end of the brace to attach it to the crossarm and tripod mast or tower. The figure also indicates what orientation is needed when the small bracket is used.

NOTE

Each bracket has a long tab and short tab where the bolts are attached. The brace arm must be attached to the end with the long tab.

2. Attach one end of the brace arm to the tripod mast or tower below the crossarm. Leave the bolts finger-tight.
3. Lift the free end of the brace arm to the crossarm and attach it to the crossarm. Again, only finger-tighten the bolts.
4. Adjust the position of the brace arm as needed.
5. Fully tighten the two bolts directly connected to the brace arm, and then tighten the remaining two bolts to clamp the brace arm to the crossarm and tower or tripod mast.

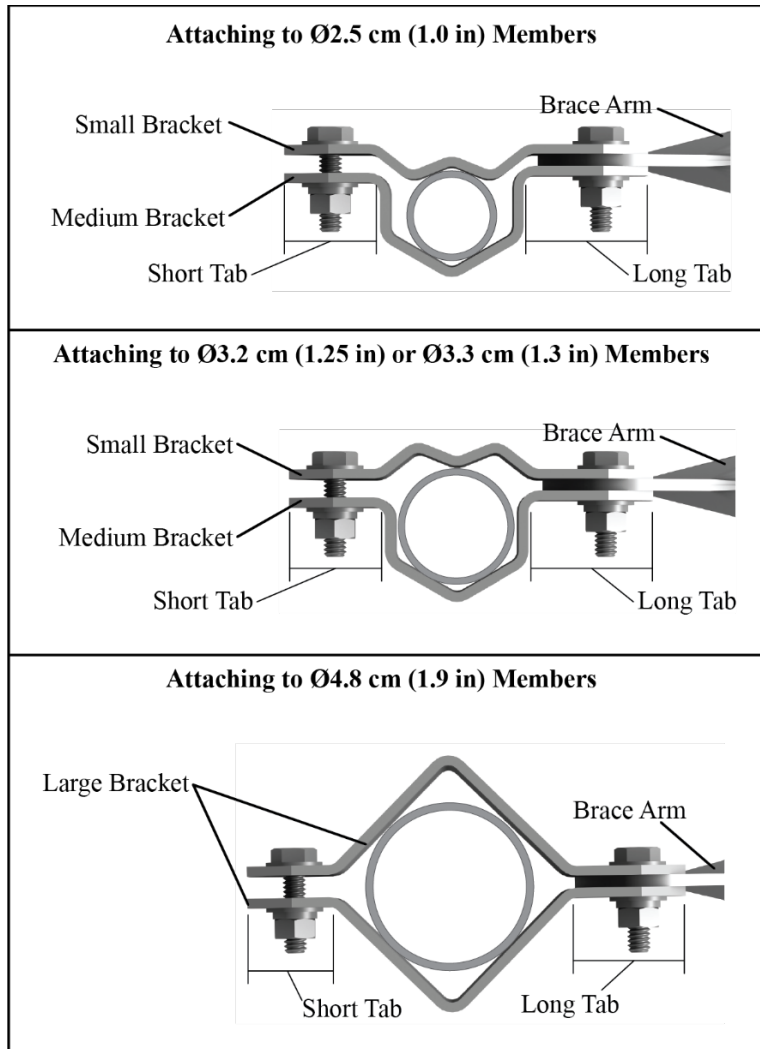

FIGURE 6-18. Bracket selection

TABLE 6-1. Bracket Requirements			
Mast/Crossarm/ Tower Diameter	Example Mast/Crossarm/Tower	Brackets Needed	Small Bracket Orientation
2.5 cm (1 in)	UT10/20/30 Tower Leg (excludes bottom section of UT20/30)	(1) Small Bracket (1) Medium Bracket	Angled toward mast/tripod
3.2 cm (1.25 in) or 3.3 cm (1.31 in)	CM202/3/4/6 Crossarm, UT20/30 Tower Mast, UT20/30 Tower Leg (bottom section only)	(1) Small Bracket (1) Medium Bracket	Angled away from mast/tripod
4.8 cm (1.9 in)	CM110/106B Tripod Mast, UT10 Tower Mast	(2) Large Bracket	N/A

6.3 Center Duckbill Anchor Kit

The Center Duckbill Anchor Kit is used to provide additional stability to the tripod. By providing an anchor directly under the center of the tripod, it can be firmly secured to the ground.

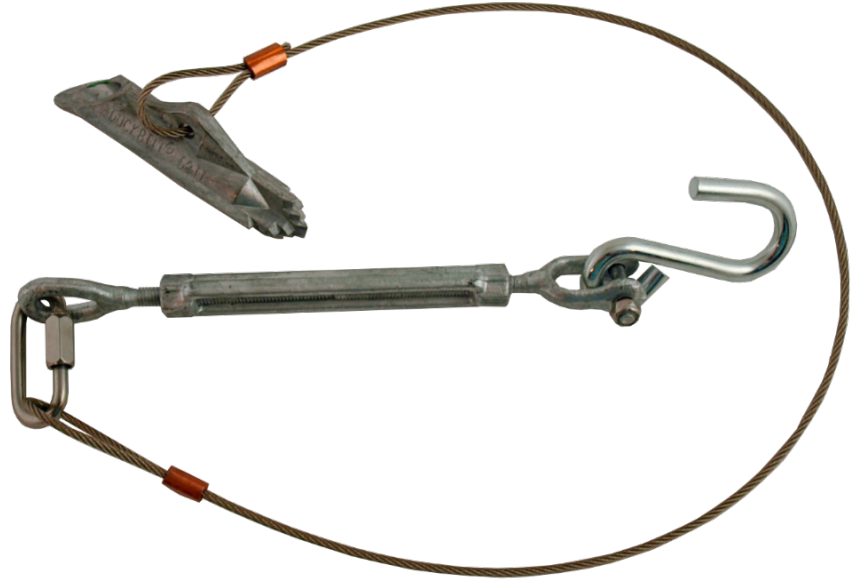
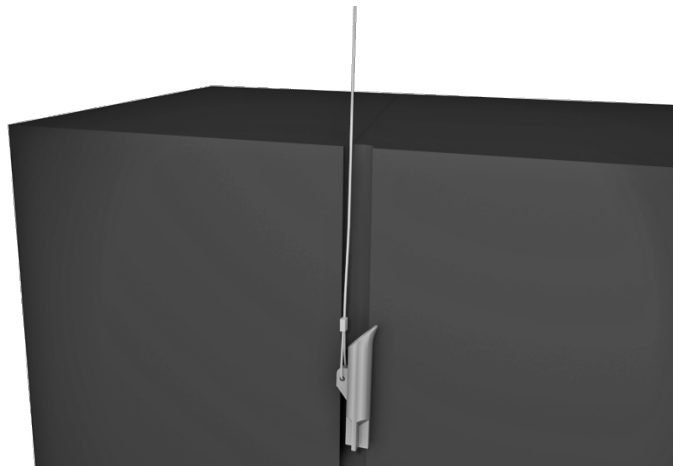

FIGURE 6-19. Center Duckbill Anchor Kit

6.3.1 Installation

1. Locate the position on the ground directly below the tripod mast. It is recommended to perform this procedure prior to driving the ground stakes through the tripod feet. This allows the tripod to be moved to one side to provide clearance when driving the duckbill anchor into the ground.
2. Insert a steel drive rod into the duckbill and drive the anchor straight down into the ground using a fence post pounder or sledgehammer until only the top half of the cable loop remains above ground.



3. Attach a high-lift jack to the loop and jack the anchor up about 6 inches to rotate the anchor into the load-lock position.



4. Move the tripod back into position. Loosen the turnbuckle evenly at both ends until the hook at the top end can be slipped over one of the leg mounting bolts at the bottom of the tripod base.



5. Tighten the turnbuckle until the tripod is firmly secured to the anchor.

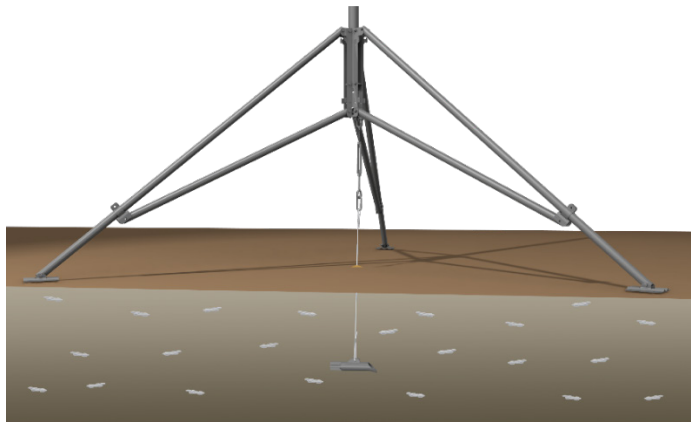

6. Install the ground spikes in the tripod feet as described in Section 6.1.4, *Staking the Tripod Feet* (p. 12).

Appendix A. CM106B Allowable Wind Speeds

CM106B load ratings assume:

- Sensors (effective area = 0.13 m^2 (1.4 ft^2)) at top of mast
- Solar panel ($26.7 \times 41.9 \text{ cm}$ ($10.5 \times 16.5 \text{ in}$)) at mast base
- ENC14/16 mounted to leg
- Guy wires attached to mast at 1.2 m (3.8 ft) above tripod body
- Adequate ground anchors (stakes alone may not resist foot vertical pullout force)

Tripod Footprint Dia.		Mast Height		Mast Configuration	Guy Anchors	Max. Allowable Gust Wind Speed		Max. Allowable Equipment Weight		Foot Vertical Pullout Force at Gust Speed		Guy-Wire Tension at Gust Speed		Ideal Guy-Wire Installation Pre-Tension	
m	ft	m	ft			mph	m/s	kN	lb	kN	lb	kN	lb	kN	lb
3.5	11.5	2.1	7	Retracted	Unguyed	104	46	4.3	964	0.31	70	-	-	-	-
					Attached to legs @ feet, 45deg Zenith	159	71	2.8	639	0.73	163	1.3	300	0.67	150
					Independent anchors @ 45deg Zenith	159	71	2.8	639	0.25	56	1.3	300	0.67	150
2.7	8.7	2.8	9.3	Retracted	Unguyed	104	46	4.3	964	0.71	160	-	-	-	-
					Attached to legs @ feet	159	71	1.9	438	1.57	352	1.8	400	0.89	200
					Independent anchors @ 45deg Zenith	159	71	2.8	639	0.69	155	1.3	300	0.67	150
3.5	11.5	3.0	10	Extended	Unguyed	81	36	4.3	964	0.26	59	-	-	-	-
					Attached to legs @ feet, 45deg Zenith	132	59	2.4	544	0.70	157	1.8	400	0.89	200
					Independent anchors @ 45deg Zenith	132	59	2.4	544	0.08	17	1.8	400	0.89	200

Tripod Footprint Dia.		Mast Height		Mast Configuration	Guy Anchors	Max. Allowable Gust Wind Speed		Max. Allowable Equipment Weight		Foot Vertical Pullout Force at Gust Speed		Guy-Wire Tension at Gust Speed		Ideal Guy-Wire Installation Pre-Tension	
m	ft	m	ft			mph	m/s	kN	lb	kN	lb	kN	lb	kN	lb
2.7	8.7	3.7	12.3	Extended	Unguyed	81	36	4.3	964	0.54	121	-	-	-	-
					Attached to legs @ feet	116	52	1.9	438	1.10	248	1.8	400	0.89	200
					Independent anchors @ 45deg Zenith	132	59	2.4	544	0.31	69	1.8	400	0.89	200

Global Sales & Support Network

A worldwide network to help meet your needs



Australia

Location: Garbutt, QLD Australia
Phone: 61.7.4401.7700
Email: info@campbellsci.com.au
Website: www.campbellsci.com.au

Brazil

Location: São Paulo, SP Brazil
Phone: 11.3732.3399
Email: vendas@campbellsci.com.br
Website: www.campbellsci.com.br

Canada

Location: Edmonton, AB Canada
Phone: 780.454.2505
Email: dataloggers@campbellsci.ca
Website: www.campbellsci.ca

China

Location: Beijing, P. R. China
Phone: 86.10.6561.0080
Email: info@campbellsci.com.cn
Website: www.campbellsci.com

Costa Rica

Location: San Pedro, Costa Rica
Phone: 506.2280.1564
Email: info@campbellsci.cc
Website: www.campbellsci.cc

France

Location: Vincennes, France
Phone: 0033.0.1.56.45.15.20
Email: info@campbellsci.fr
Website: www.campbellsci.fr

Germany

Location: Bremen, Germany
Phone: 49.0.421.460974.0
Email: info@campbellsci.de
Website: www.campbellsci.de

India

Location: New Delhi, DL India
Phone: 91.11.46500481.482
Email: info@campbellsci.in
Website: www.campbellsci.in

South Africa

Location: Stellenbosch, South Africa
Phone: 27.21.8809960
Email: sales@campbellsci.co.za
Website: www.campbellsci.co.za

Spain

Location: Barcelona, Spain
Phone: 34.93.2323938
Email: info@campbellsci.es
Website: www.campbellsci.es

Thailand

Location: Bangkok, Thailand
Phone: 66.2.719.3399
Email: info@campbellsci.asia
Website: www.campbellsci.asia

UK

Location: Shepshed, Loughborough, UK
Phone: 44.0.1509.601141
Email: sales@campbellsci.co.uk
Website: www.campbellsci.co.uk

USA

Location: Logan, UT USA
Phone: 435.227.9120
Email: info@campbellsci.com
Website: www.campbellsci.com