

# 30066 BATTERY TERMINAL BUS

The 30066 battery terminal bus attaches to the BP84 (or other VRLA battery with similar terminals). It provides fused protection between the battery and any device attached to the battery terminal BUS.

Each 30066 contains two battery terminal buses (pn 4386), each featuring four wire-terminal connections. Two terminals on each bus allow a charging device (such as CH200 or Sun saver-10) to be attached to the battery while providing protection with a 14-Amp fuse. The remaining two terminals on each bus connect to a datalogger, or other device, with a 5-Amp fuse. Refer to the diagram below when attaching wires to the battery terminal bus.

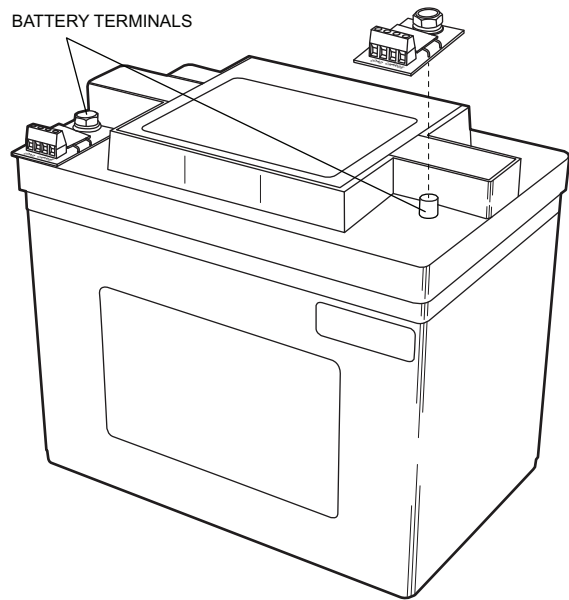

1. Attach one battery terminal bus from the 30066 to each terminal on the battery. Orient each battery terminal bus as shown.
2. Use a red wire to connect the battery charger (+) terminal to the CHARGE terminal on the positive battery post.
3. Use a red wire to connect the datalogger or other device to the LOAD terminal on the positive battery post.
4. Use a black wire to connect the battery charger (-) terminal to the CHARGE terminal on the negative battery post.
5. Use a black wire to connect the datalogger or other device to the LOAD terminal on the negative battery post.

**NOTE:** Recommend 18-AWG to 16-AWG wire for all "CHARGE" connections. Recommend 22 AWG minimum for all "LOAD" connections.

