

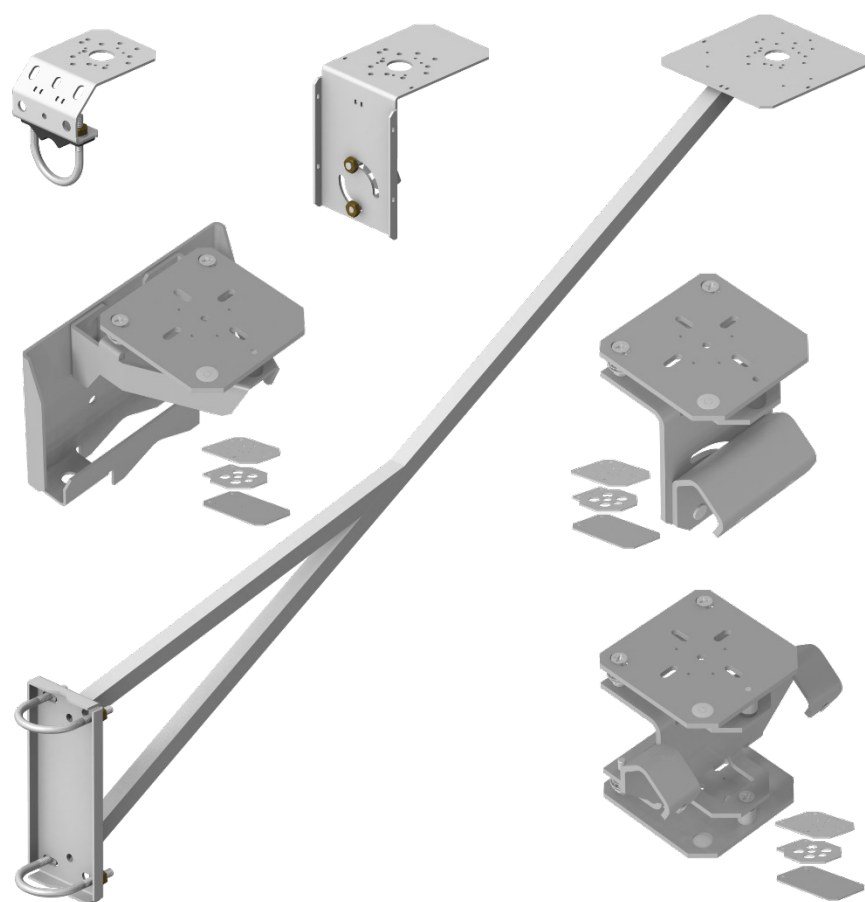

# Solar Radiation Sensor Mounts



Revision: 10/20

Copyright © 2016 – 2020  
Campbell Scientific, Inc.



# Table of Contents

---

*PDF viewers: These page numbers refer to the printed version of this document. Use the PDF reader bookmarks tab for links to specific sections.*

<b>1. Introduction.....</b>	<b>1</b>
<b>2. Precautions.....</b>	<b>2</b>
<b>3. Initial Inspection .....</b>	<b>2</b>
<b>4. Overview .....</b>	<b>2</b>
<b>5. Specifications .....</b>	<b>3</b>
<b>6. Installation .....</b>	<b>5</b>
6.1 Siting.....	5
6.2 Installation.....	6
<b>7. Maintenance.....</b>	<b>9</b>

## **Figures**

1-1. Pyranometer mounting brackets.....	1
4-1. CM255 mounted level and at an angle.....	2
6-1. Solar sensor placement.....	5
6-2. Mounting plates with compatible sensors .....	6
6-3. 015ARM and CM255 showing U-bolt mounting.....	7
6-4. CM256 (CM275 inset).....	8
6-5. CM226 showing horizontal and vertical mount options .....	8

# Solar Radiation Sensor Mounts

---

## 1. Introduction

The CM225, CM255, CM256, CM261, CM275, and 015ARM solar radiation sensor mounts (FIGURE 1-1) are designed to be mounted on a mast, crossarm, or pole. The mounting holes on the top plate allow a wide variety of sensors to be mounted. The CM256, CM261, and CM275 have four different mounting plate options to allow a larger number of sensors to use the mount. In addition, the CM261 has three torque tube mounting options.

The CM226 is designed to mount on a mast, crossarm, or pole up to 5 cm (2 in) diameter. This mount includes the leveling base required by smaller sensors such as the Apogee CS301.

The CM225 is designed to be mounted either horizontally to a crossarm or vertically to a mast or a pole to keep the mounting plate level. The CM255 and CM256 can also be mounted horizontally or vertically, but include a 90° adjustment. This allows the mount to be positioned at different angles, as shown in FIGURE 4-1. The CM261 is designed specifically for securing a pyranometer near the end cap of an ATI or NexTracker torque tube. It can also be used with any other 12.7 cm (5 in) diameter tube. The CM275 is a universal solar albedo mounting stand to mount any downwelling/upwelling combination of pyranometer, ventilation unit, reference cell, or spectral radiometer. The 015ARM mounts to a vertical mast or tripod.

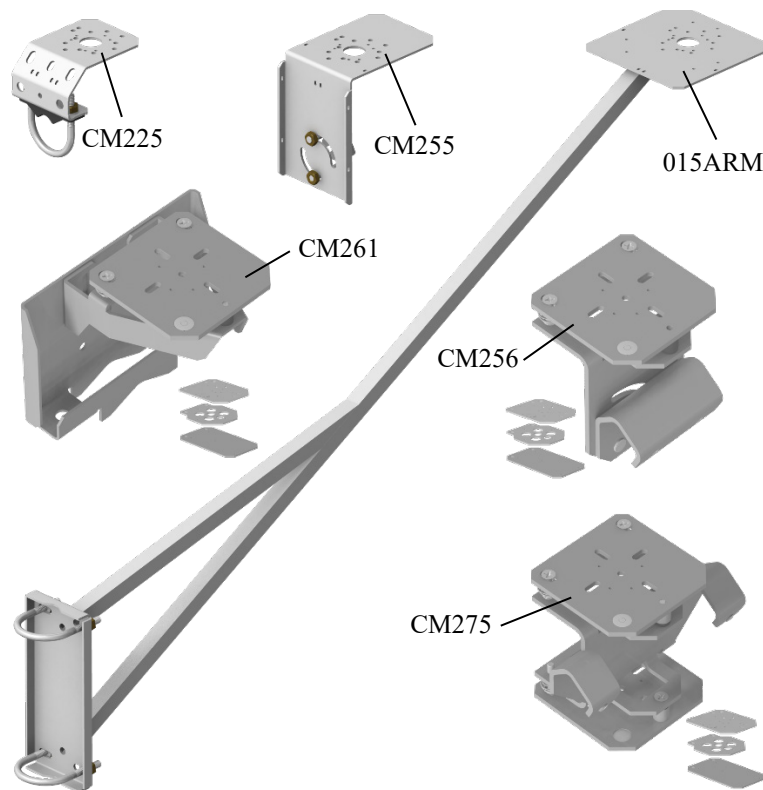

FIGURE 1-1. Pyranometer mounting brackets

## 2. Precautions

- READ AND UNDERSTAND the *Safety* section at the back of this manual.
- WARNING — Ensure the mounting bracket is securely fastened during setup and weather extremes to minimize the chance of damaging the instruments. Read all instructions carefully.

## 3. Initial Inspection

- Upon receiving the solar radiation sensor mount, inspect the packaging and contents for damage. Claims for shipping damage must be filed with the shipping company.
- Locate the packing slip for the order and compare the items listed on the packing slip to the items that were actually shipped. Report any discrepancies to Campbell Scientific.

## 4. Overview

Campbell Scientific solar radiation sensor mounts provide a stable mounting platform for a pyranometer, quantum sensor, or radiometer. The flexibility in these designs allows a sensor to be mounted to a horizontal crossarm, or to a vertical mast or tower. The CM255 and CM256 may be mounted at different angles, depending on the user's needs (FIGURE 4-1). The CM275 allows the mounting of a downwelling/upwelling combination of pyranometer, ventilation, reference cell, or spectral radiometer. With the 015ARM, the sensor is mounted away from the vertical pipe, allowing for a more unobstructed view of the sky.

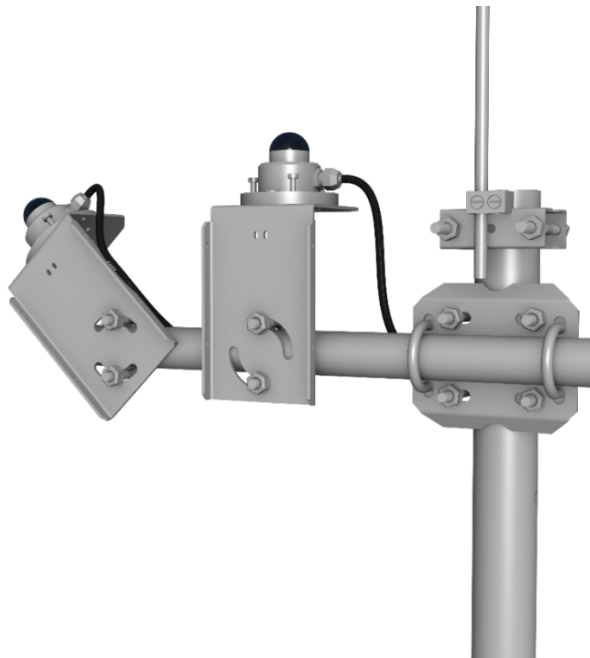

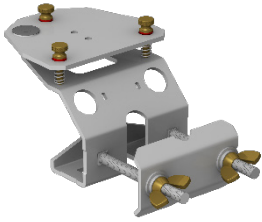

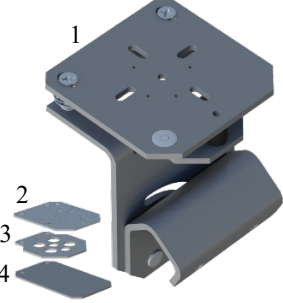
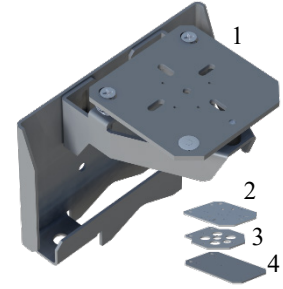
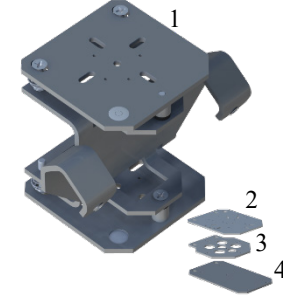
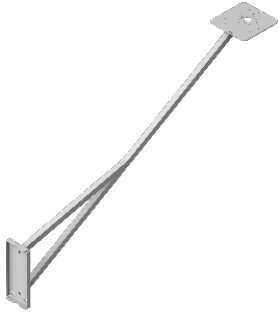

FIGURE 4-1. CM255 mounted level and at an angle

## 5. Specifications

Mount	Description	Compatible Sensors <sup>1</sup>	Mounts to
<p><b>CM225</b> Solar Sensor Mounting Stand</p> 	<p>Consists of a rectangular plate, mounting bracket, and mounting hardware. Dimensions are 8.9 x 11.3 x 6.4 cm (3.5 x 4.5 x 2.5 in), and weight is 0.34 kg (0.75 lb).</p>	<p>CS300<sup>2</sup>, LI200X<sup>2</sup>, LI200S<sup>2</sup>, LI190R<sup>2</sup>, LI190SB<sup>2</sup>, CMP3, CMP6<sup>3</sup>, CMP11<sup>3</sup>, CMP21<sup>3</sup>, LP02, SP-LITE, PQS1</p>	<p><b>U-bolt in bottom holes</b> CM202, CM202SS, CM203, CM204, CM204SS, or CM206 crossarm</p> <p><b>U-bolt in side holes</b> tripod or tower mast or user-supplied pipe with 2.5 to 5.1 cm (1.0 to 2.0 in) OD</p>
<p><b>CM226</b> Solar Sensor Mounting Stand with Level and Base</p> 	<p>Designed for Apogee solar sensors, this mount combines the leveling and mounting hardware needed to install the sensor. Dimensions are 15.2 x 9.1 x 9.1 cm (6.0 x 3.6 x 3.6 in), and weight is 0.36 kg (0.8 lb).</p>	<p>CS300, CS301, CS310, CS320, SP230SS</p>	<p>CM300, CM305, CM310, or any crossarm, mast, or user-supplied pipe with a 5.1 cm (2.0 in) OD or smaller</p>
<p><b>CM255</b> Adjustable Angle, Mounting Stand</p> 	<p>Includes slots that can be adjusted to any angle from horizontal to vertical. Dimensions are 15.9 x 10.8 x 9.5 cm (6.3 x 4.3 x 3.8 in), and weight is 0.6 kg (1.3 lb).</p>	<p>CS300<sup>2</sup>, LI200X<sup>2</sup>, LI200S<sup>2</sup>, LI190R<sup>2</sup>, LI190SB<sup>2</sup>, CMP3, CMP6<sup>3</sup>, CMP11<sup>3</sup>, CMP21<sup>3</sup>, LP02, SP-LITE, PQS1 (not compatible with rotating shadowband radiometers (RSRs))</p>	<p>CM202, CM202SS, CM203, CM204, CM204SS, or CM206 crossarm, mast, or user-supplied pipe with a 2.5 to 3.8 cm (1.0 to 1.5 in) OD</p>

Mount	Description	Compatible Sensors <sup>1</sup>	Mounts to
<p><b>CM256</b> Adjustable Plane and Angle Solar Mounting Stand</p> 	<p>Includes leveling screws that allow leveling in a horizontal position and then pivoting or tilting to the correct azimuth. Base dimensions are 15.2 x 12.0 x 11.4 cm (6.0 x 4.7 x 4.5 in), and weight is 0.7 kg (1.5 lb). Four mounting plate options are available.</p>	<p>–SP option: MS-40/60/80, MS-40M/60M/80M, SR30, SR05, SR11, SR15, SR20-T2, SR20-D2, SP Lite 2, CMP3/6/10/11/21/22, SMP3/6/10/11/21/22, CGR3/4, and SGR3/4.</p> <p>–LP option: SPN1, PSP, GPP, SPP, and Si-01TC Reference Cell (CS325DM).</p> <p>–VN option: VU01 and MV-01.</p> <p>–CV option: CVF4</p>	<p>CM202, CM202SS, CM203, CM204, CM204SS, or CM206 crossarm, mast, or user-supplied pipe with a 3.3 cm (1.3 in) OD</p>
<p><b>CM261</b> Single-Axis Tracker Mounting Stand for Hexagonal, Round, and Square Single-Axis Torque Tubes</p> 	<p>Choose from ATI, NexTracker, or generic torque tube options when ordering. Dimensions are 15.2 x 15.2 x 20.3 cm (6.0 x 6.0 x 8.0 in), and weight is 3.6 kg (8.0 lb). Four mounting plate options are available.</p>	<p>–SP option: MS-40/60/80, MS-40M/60M/80M, SR30, SR05, SR11, SR15, SR20-T2, SR20-D2, SP Lite 2, CMP3/6/10/11/21/22, SMP3/6/10/11/21/22, CGR3/4, and SGR3/4.</p> <p>–LP option: SPN1, PSP, GPP, SPP, and Si-01TC Reference Cell (CS325DM).</p> <p>–VN option: VU01 and MV-01.</p> <p>–CV option: CVF4</p>	<p>ATI or NEXTracker torque tube, or any 12.7 cm (5.0 in) diameter tube</p>
<p><b>CM275</b> Albedometer Mounting Kit</p> 	<p>Universal solar albedo mounting stand to mount any downwelling/upwelling combination of pyranometer, ventilation unit, reference cell, or spectral radiometer. Dimensions are 14.0 x 12.0 x 18.3 cm (5.5 x 4.7 x 7.2 in), and weight is 0.7 kg (1.5 lb). Four mounting plate options are available.</p>	<p>–SP option: MS-40/60/80, MS-40M/60M/80M, SR30, SR05, SR11, SR15, SR20-T2, SR20-D2, SP Lite 2, CMP3/6/10/11/21/22, SMP3/6/10/11/21/22, CGR3/4, and SGR3/4.</p> <p>–LP option: SPN1, PSP, GPP, SPP, and Si-01TC Reference Cell (CS325DM).</p> <p>–VN option: VU01 and MV-01.</p> <p>–CV option: CVF4</p>	<p>CM202, CM202SS, CM203, CM204, CM204SS, or CM206 crossarm, mast, or user-supplied pipe with a 3.3 cm (1.3 in) OD</p>

Mount	Description	Compatible Sensors <sup>1</sup>	Mounts to
<p><b>015ARM</b> Solar Sensor Mounting Arm</p> 	<p>Consists of a square platform, mounting arm, and mounting hardware. Platform area is 15.2 x 15.2 cm (6.0 x 6.0 in), arm length is 106.7 cm (42.0 in), and weight is 2.5 kg (5.5 lb).</p>	<p>CS300<sup>2</sup>, LI200X<sup>2</sup>, LI200S<sup>2</sup>, LI190R<sup>2</sup>, LI190SB<sup>2</sup>, CMP3<sup>3</sup>, CMP6<sup>3</sup>, CMP11<sup>3</sup>, CMP21<sup>3</sup>, LP02</p>	<p>Tripod or tower mast or user-supplied pipe with 2.5 to 3.8 cm (1.0 to 1.5 in) OD</p>
<p><sup>1</sup> Retired sensors may also be compatible. Contact Campbell Scientific for more information.  <sup>2</sup> A leveling base is required to mount the CS300, LI200X, LI200S, LI190R, or LI190SB.  <sup>3</sup> Assumes the CMP6, CMP11, and CMP21 are not housed in the CVF4 Heater/Ventilation Unit.  <sup>4</sup> Assumes the SR20-T2-L is not housed in the VU01 Heater/Ventilation Unit.</p>			

### Compliance

#### CM225:

View EU Declaration of Conformity at:  
[www.campbellsci.com/cm225-solar-mount](http://www.campbellsci.com/cm225-solar-mount)

#### CM261:

View EU Declaration of Conformity at:  
[www.campbellsci.com/cm261](http://www.campbellsci.com/cm261)

## 6. Installation

### 6.1 Siting

The solar radiation sensor is usually installed horizontally, but can also be installed at any angle including an inverted position. In all cases, it will measure the flux that is incident on the surface parallel to the sensor surface. Site the sensor to allow easy access for maintenance while ideally avoiding any obstructions or reflections above the plane of the sensing element. Mount the sensor such that a shadow or a reflection will not be cast on it at any time. FIGURE 6-1 shows how to calculate the distance needed from any potential obstruction.

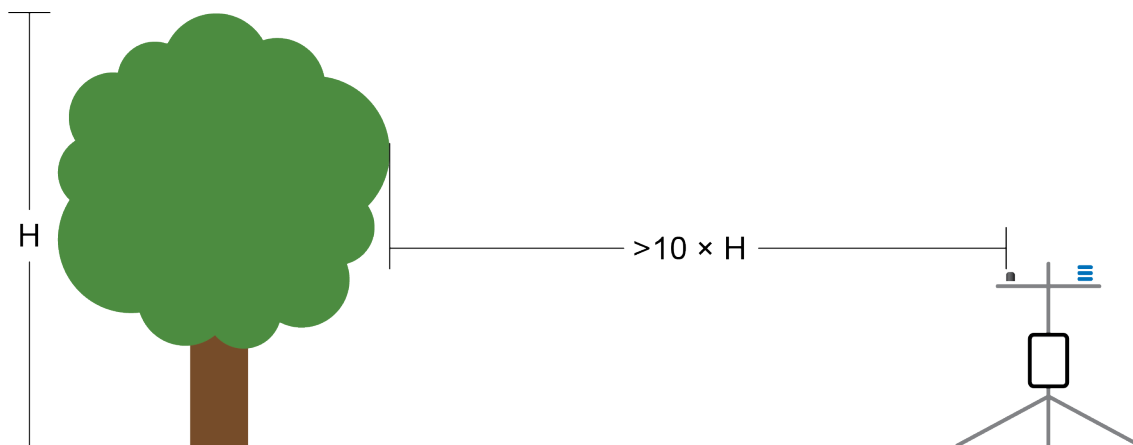

FIGURE 6-1. Solar sensor placement

If this is not possible, try to choose a site where any obstruction over the azimuth range between earliest sunrise and latest sunset has an elevation not exceeding 5°. Diffuse solar radiation is less influenced by obstructions near the horizon. For instance, an obstruction with an elevation of 5° over the whole azimuth range of 360° decreases the downward diffuse solar radiation by only 0.8%. The sensor should be mounted with the cable pointing towards the nearest magnetic pole. For example, in the Northern Hemisphere, point the cable toward the North Pole.

## 6.2 Installation

1. On a level surface, level the solar radiation sensor using the leveling feet on the sensor. Alternatively, remove the sensor leveling feet to allow it to be mounted directly to the mounting bracket. Smaller sensors, such as the CS301, do not have leveling feet and must be mounted directly to a leveling base.
2. Secure the solar radiation sensor to the mounting bracket. Refer to FIGURE 6-2 to determine which mounting holes are used by the sensor. Visually inspect the leveling feet on the sensor (if present) to ensure all feet are in contact with the mounting bracket.

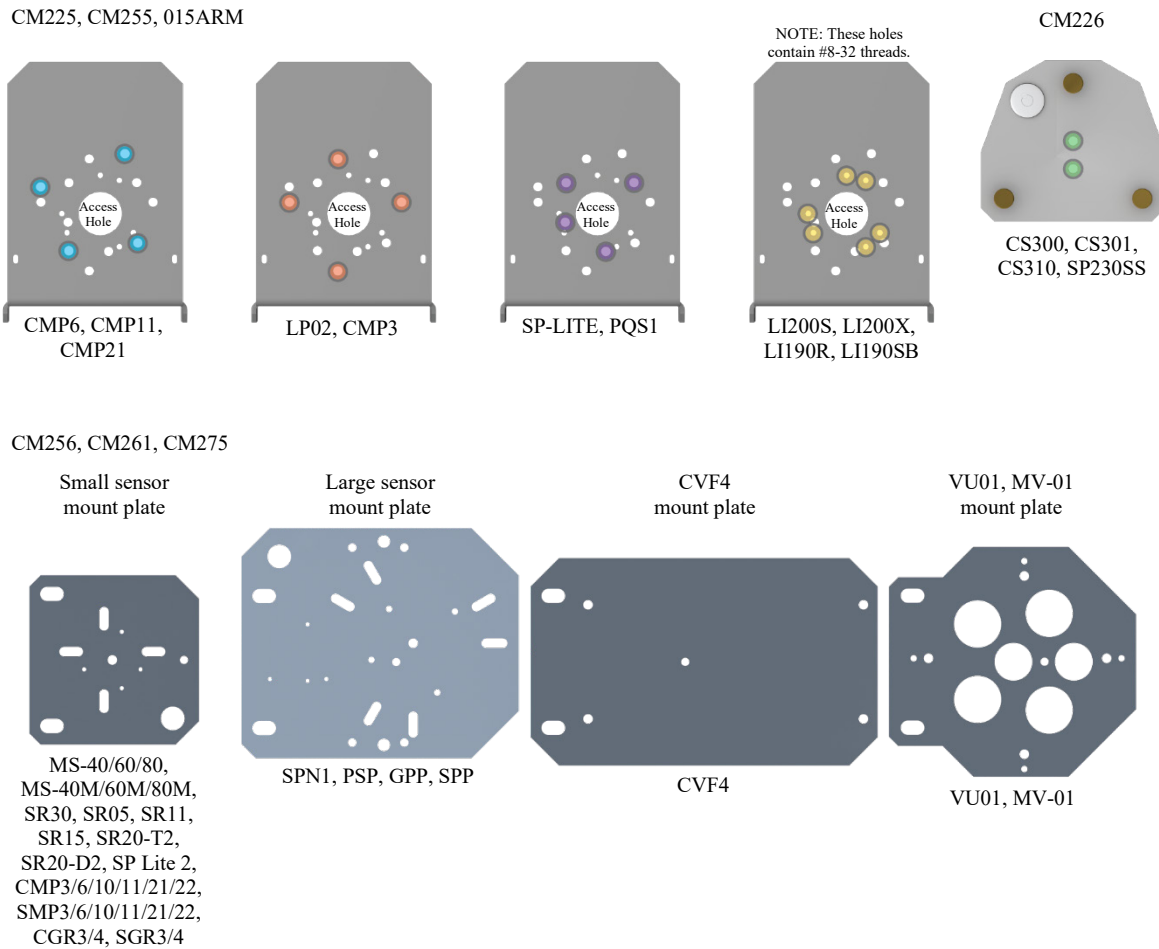

FIGURE 6-2. Mounting plates with compatible sensors



3. Using a diopter in combination with a solar compass, install and orient the crossarm on the tripod or the mast. If installing the mounting bracket on a vertical pole, ensure the pole is truly vertical.
4. Secure the mounting bracket to the crossarm or the vertical pole using the hardware included with the mounting bracket. The CM225, CM255, CM261, and 015ARM use one or two U-bolts, nuts, flat washers, and lock washers to mount the bracket (FIGURE 6-3).

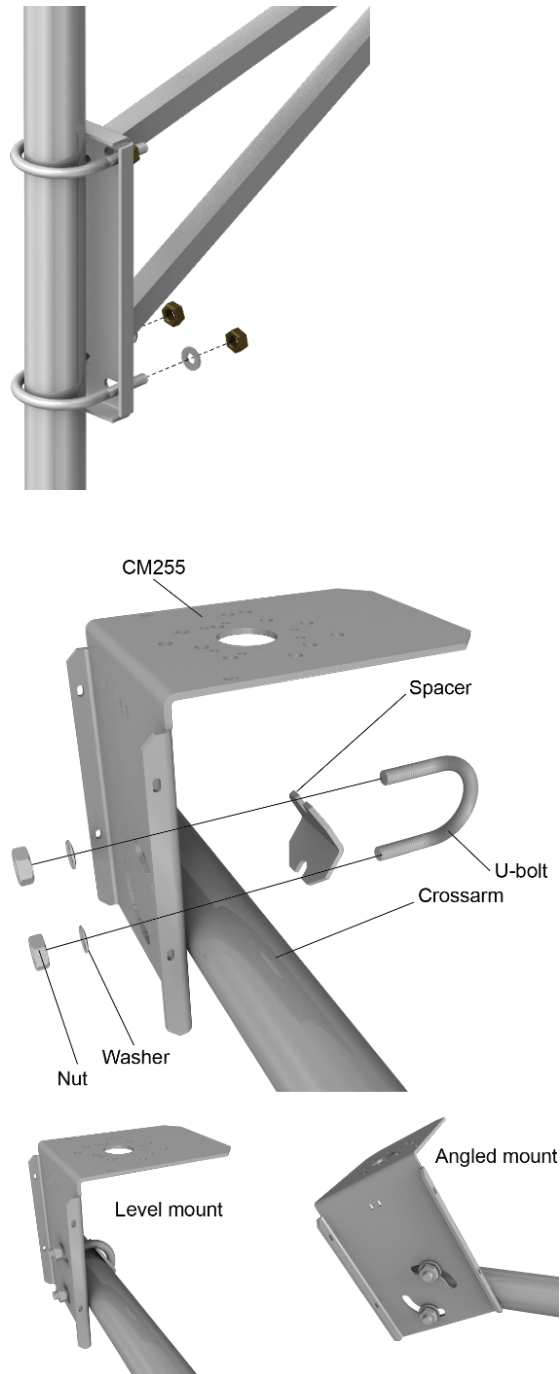

FIGURE 6-3. 015ARM and CM255 showing U-bolt mounting

- The CM256 and CM275 bracket (FIGURE 6-4) use two set screws to secure the crossarm or the pole in the channel at the base of the bracket. For pyranometers mounted horizontally, ensure the mounting bracket is horizontal in two dimensions. For pyranometers to be mounted at an angle with the CM255 or CM256, set the mounting bracket angle to the desired angle prior to tightening the mounting hardware.

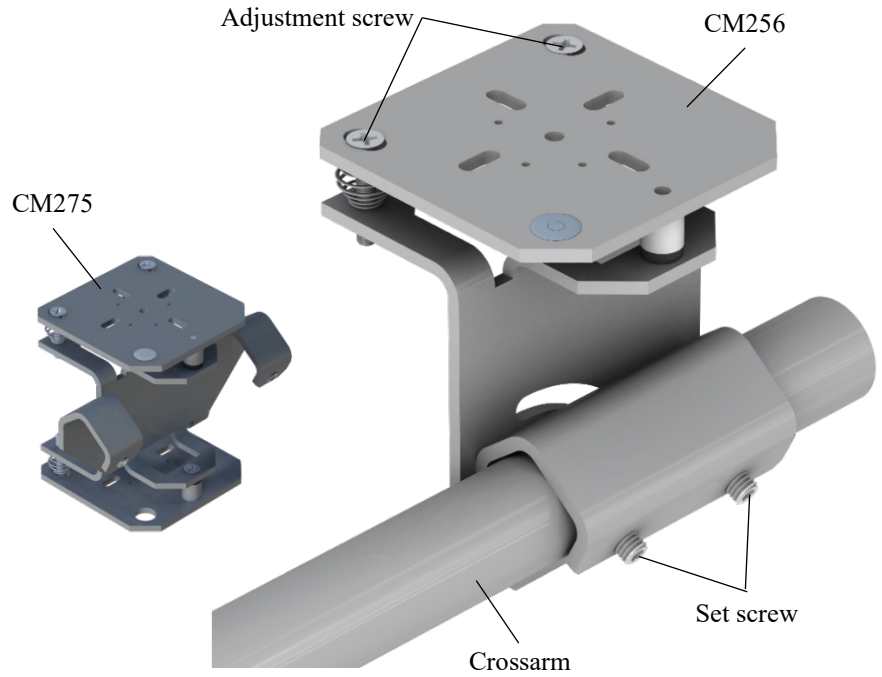

FIGURE 6-4. CM256 (CM275 inset)

- The CM226 uses two bolts, wing nuts, and a clamp piece to secure it to a crossarm or mast (FIGURE 6-5).

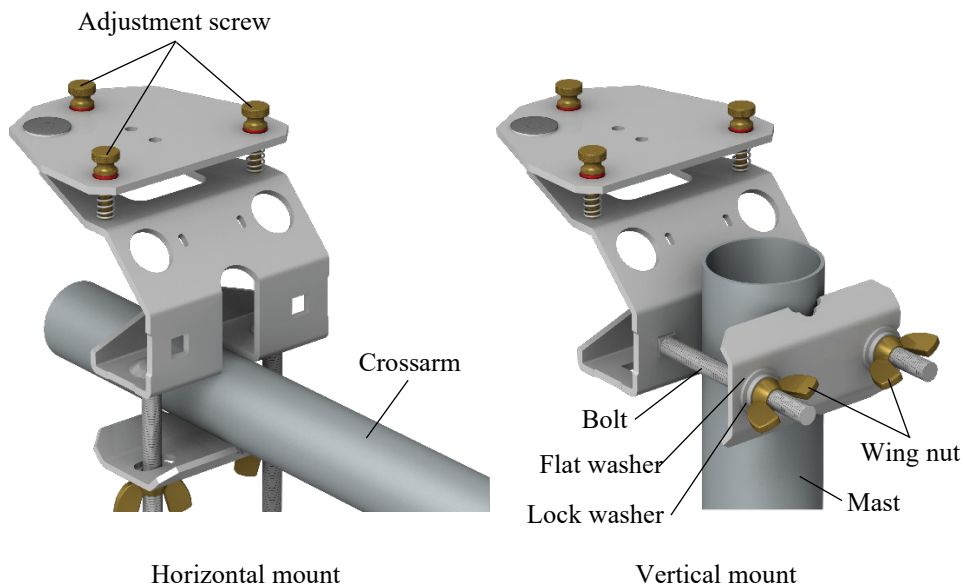

FIGURE 6-5. CM226 showing horizontal and vertical mount options

7. Verify all mounting hardware is firmly tightened, and that the mounting bracket is at the desired angle. The CM256, CM261, and CM275 include leveling bolts for additional adjustment of the pyranometer level.

## **7. Maintenance**

Periodically (at least yearly) check for wear and damage, and take necessary corrective actions. Ensure all bolts are securely tightened.

# ***Limited Warranty***

---

Products manufactured by Campbell Scientific are warranted by Campbell Scientific to be free from defects in materials and workmanship under normal use and service for twelve months from the date of shipment unless otherwise specified on the corresponding product webpage. See Product Details on the Ordering Information pages at [www.campbellsci.com](http://www.campbellsci.com). Other manufacturer's products, that are resold by Campbell Scientific, are warranted only to the limits extended by the original manufacturer.

Refer to [www.campbellsci.com/terms#warranty](http://www.campbellsci.com/terms#warranty) for more information.

**CAMPBELL SCIENTIFIC EXPRESSLY DISCLAIMS AND EXCLUDES ANY IMPLIED WARRANTIES OF MERCHANTABILITY OR FITNESS FOR A PARTICULAR PURPOSE. Campbell Scientific hereby disclaims, to the fullest extent allowed by applicable law, any and all warranties and conditions with respect to the Products, whether express, implied or statutory, other than those expressly provided herein.**

# Assistance

---

Products may not be returned without prior authorization.

Products shipped to Campbell Scientific require a Returned Materials Authorization (RMA) or Repair Reference number and must be clean and uncontaminated by harmful substances, such as hazardous materials, chemicals, insects, and pests. Please complete the required forms prior to shipping equipment.

Campbell Scientific regional offices handle repairs for customers within their territories. Please see the back page for the Global Sales and Support Network or visit [www.campbellsci.com/contact](http://www.campbellsci.com/contact) to determine which Campbell Scientific office serves your country.

To obtain a Returned Materials Authorization or Repair Reference number, contact your CAMPBELL SCIENTIFIC regional office. Please write the issued number clearly on the outside of the shipping container and ship as directed.

For all returns, the customer must provide a “Statement of Product Cleanliness and Decontamination” or “Declaration of Hazardous Material and Decontamination” form and comply with the requirements specified in it. The form is available from your CAMPBELL SCIENTIFIC regional office. Campbell Scientific is unable to process any returns until we receive this statement. If the statement is not received within three days of product receipt or is incomplete, the product will be returned to the customer at the customer’s expense. Campbell Scientific reserves the right to refuse service on products that were exposed to contaminants that may cause health or safety concerns for our employees.

# Safety

---

**DANGER — MANY HAZARDS ARE ASSOCIATED WITH INSTALLING, USING, MAINTAINING, AND WORKING ON OR AROUND TRIPODS, TOWERS, AND ANY ATTACHMENTS TO TRIPODS AND TOWERS SUCH AS SENSORS, CROSSARMS, ENCLOSURES, ANTENNAS, ETC. FAILURE TO PROPERLY AND COMPLETELY ASSEMBLE, INSTALL, OPERATE, USE, AND MAINTAIN TRIPODS, TOWERS, AND ATTACHMENTS, AND FAILURE TO HEED WARNINGS, INCREASES THE RISK OF DEATH, ACCIDENT, SERIOUS INJURY, PROPERTY DAMAGE, AND PRODUCT FAILURE. TAKE ALL REASONABLE PRECAUTIONS TO AVOID THESE HAZARDS. CHECK WITH YOUR ORGANIZATION'S SAFETY COORDINATOR (OR POLICY) FOR PROCEDURES AND REQUIRED PROTECTIVE EQUIPMENT PRIOR TO PERFORMING ANY WORK.**

Use tripods, towers, and attachments to tripods and towers only for purposes for which they are designed. Do not exceed design limits. Be familiar and comply with all instructions provided in product manuals. Manuals are available at [www.campbellsci.com](http://www.campbellsci.com). You are responsible for conformance with governing codes and regulations, including safety regulations, and the integrity and location of structures or land to which towers, tripods, and any attachments are attached. Installation sites should be evaluated and approved by a qualified engineer. If questions or concerns arise regarding installation, use, or maintenance of tripods, towers, attachments, or electrical connections, consult with a licensed and qualified engineer or electrician.

## General

- Protect from over-voltage.
- Protect electrical equipment from water.
- Protect from electrostatic discharge (ESD).
- Protect from lightning.
- Prior to performing site or installation work, obtain required approvals and permits. Comply with all governing structure-height regulations.
- Use only qualified personnel for installation, use, and maintenance of tripods and towers, and any attachments to tripods and towers. The use of licensed and qualified contractors is highly recommended.
- Read all applicable instructions carefully and understand procedures thoroughly before beginning work.
- Wear a **hardhat** and **eye protection**, and take **other appropriate safety precautions** while working on or around tripods and towers.
- **Do not climb** tripods or towers at any time, and prohibit climbing by other persons. Take reasonable precautions to secure tripod and tower sites from trespassers.
- Use only manufacturer recommended parts, materials, and tools.

## Utility and Electrical

- **You can be killed** or sustain serious bodily injury if the tripod, tower, or attachments you are installing, constructing, using, or maintaining, or a tool, stake, or anchor, come in **contact with overhead or underground utility lines**.
- Maintain a distance of at least one-and-one-half times structure height, 6 meters (20 feet), or the distance required by applicable law, **whichever is greater**, between overhead utility lines and the structure (tripod, tower, attachments, or tools).
- Prior to performing site or installation work, inform all utility companies and have all underground utilities marked.
- Comply with all electrical codes. Electrical equipment and related grounding devices should be installed by a licensed and qualified electrician.
- Only use power sources approved for use in the country of installation to power Campbell Scientific devices.

## Elevated Work and Weather

- Exercise extreme caution when performing elevated work.
- Use appropriate equipment and safety practices.
- During installation and maintenance, keep tower and tripod sites clear of un-trained or non-essential personnel. Take precautions to prevent elevated tools and objects from dropping.
- Do not perform any work in inclement weather, including wind, rain, snow, lightning, etc.

## Maintenance

- Periodically (at least yearly) check for wear and damage, including corrosion, stress cracks, frayed cables, loose cable clamps, cable tightness, etc. and take necessary corrective actions.
- Periodically (at least yearly) check electrical ground connections.

## Internal Battery

- Be aware of fire, explosion, and severe-burn hazards.
- Misuse or improper installation of the internal lithium battery can cause severe injury.
- Do not recharge, disassemble, heat above 100 °C (212 °F), solder directly to the cell, incinerate, or expose contents to water. Dispose of spent batteries properly.

WHILE EVERY ATTEMPT IS MADE TO EMBODY THE HIGHEST DEGREE OF SAFETY IN ALL CAMPBELL SCIENTIFIC PRODUCTS, THE CUSTOMER ASSUMES ALL RISK FROM ANY INJURY RESULTING FROM IMPROPER INSTALLATION, USE, OR MAINTENANCE OF TRIPODS, TOWERS, OR ATTACHMENTS TO TRIPODS AND TOWERS SUCH AS SENSORS, CROSSARMS, ENCLOSURES, ANTENNAS, ETC.



## Global Sales & Support Network

A worldwide network to help meet your needs



### Campbell Scientific regional offices

#### Australia

*Location:* Garbutt, QLD Australia  
*Phone:* 61.7.4401.7700  
*Email:* [info@campbellsci.com.au](mailto:info@campbellsci.com.au)  
*Website:* [www.campbellsci.com.au](http://www.campbellsci.com.au)

#### Brazil

*Location:* São Paulo, SP Brazil  
*Phone:* 11.3732.3399  
*Email:* [vendas@campbellsci.com.br](mailto:vendas@campbellsci.com.br)  
*Website:* [www.campbellsci.com.br](http://www.campbellsci.com.br)

#### Canada

*Location:* Edmonton, AB Canada  
*Phone:* 780.454.2505  
*Email:* [dataloggers@campbellsci.ca](mailto:dataloggers@campbellsci.ca)  
*Website:* [www.campbellsci.ca](http://www.campbellsci.ca)

#### China

*Location:* Beijing, P. R. China  
*Phone:* 86.10.6561.0080  
*Email:* [info@campbellsci.com.cn](mailto:info@campbellsci.com.cn)  
*Website:* [www.campbellsci.com.cn](http://www.campbellsci.com.cn)

#### Costa Rica

*Location:* San Pedro, Costa Rica  
*Phone:* 506.2280.1564  
*Email:* [info@campbellsci.cc](mailto:info@campbellsci.cc)  
*Website:* [www.campbellsci.cc](http://www.campbellsci.cc)

#### France

*Location:* Vincennes, France  
*Phone:* 0033.0.1.56.45.15.20  
*Email:* [info@campbellsci.fr](mailto:info@campbellsci.fr)  
*Website:* [www.campbellsci.fr](http://www.campbellsci.fr)

#### Germany

*Location:* Bremen, Germany  
*Phone:* 49.0.421.460974.0  
*Email:* [info@campbellsci.de](mailto:info@campbellsci.de)  
*Website:* [www.campbellsci.de](http://www.campbellsci.de)

#### India

*Location:* New Delhi, DL India  
*Phone:* 91.11.46500481.482  
*Email:* [info@campbellsci.in](mailto:info@campbellsci.in)  
*Website:* [www.campbellsci.in](http://www.campbellsci.in)

#### South Africa

*Location:* Stellenbosch, South Africa  
*Phone:* 27.21.8809960  
*Email:* [sales@campbellsci.co.za](mailto:sales@campbellsci.co.za)  
*Website:* [www.campbellsci.co.za](http://www.campbellsci.co.za)

#### Spain

*Location:* Barcelona, Spain  
*Phone:* 34.93.2323938  
*Email:* [info@campbellsci.es](mailto:info@campbellsci.es)  
*Website:* [www.campbellsci.es](http://www.campbellsci.es)

#### Thailand

*Location:* Bangkok, Thailand  
*Phone:* 66.2.719.3399  
*Email:* [info@campbellsci.asia](mailto:info@campbellsci.asia)  
*Website:* [www.campbellsci.asia](http://www.campbellsci.asia)

#### UK

*Location:* Shepshed, Loughborough, UK  
*Phone:* 44.0.1509.601141  
*Email:* [sales@campbellsci.co.uk](mailto:sales@campbellsci.co.uk)  
*Website:* [www.campbellsci.co.uk](http://www.campbellsci.co.uk)

#### USA

*Location:* Logan, UT USA  
*Phone:* 435.227.9120  
*Email:* [info@campbellsci.com](mailto:info@campbellsci.com)  
*Website:* [www.campbellsci.com](http://www.campbellsci.com)